

Hako



Citymaster 1650 (1491)

Operating Manual

Issue: 05.2021

Part number: 88103158-4393-02

Introduction

Foreword

Dear customer,

We are certain that the excellent qualities of the vehicle will justify the faith you have shown in us by your purchase.

To guarantee you safe working with the vehicle, please read the Safety Notes chapter before putting it into service.

Your own safety, as well as the safety of others, depends essentially on your ability to control the vehicle. Please read this **original operating manual** before you use the vehicle for the first time, act accordingly and keep these instructions for future reference or subsequent users. The operating manual (to ISO 3600) contains all important information for operation, maintenance and care. We have provided the places in this operating manual concerning your safety with a danger pictogram. Your authorised Hako dealer is available at all times to answer further questions about the vehicle or the operating manual.

We would expressly advise you that no legal claims may be asserted based on the contents of this operating manual. In the case of necessary repair work, please make sure that only original spare parts are used. Spare parts must be original spare parts to guarantee safety. We reserve the right to make changes in the interests of further technical development.

Hako GmbH
23843 Bad Oldesloe, Germany
Hamburger Str. 209-239
Phone +49 4531 806-0

Issue:

Index	Part number	Valid as from:	Machine number
01	88-10-3158-4037-00	10.2019	WHW14911590003100
02	88-10-3158-4393-01	12.2020	WHW14911590003100
03	88-10-3158-4393-02	05.2021	WHW14911590003100

Applications

The Citymaster 1650 is a multi-purpose machine for commercial and municipal use throughout the year. Thanks to special attachments, the Citymaster 1650 can be used for various applications. The basic vehicle **Fig. 1-A** without attachments is described in chapter 1 to 5. The following attachments are described in chapter 6.

- Vacuum sweeping system with the sweeping unit, suction mouth, dirt hopper and trolley.
- Lawn mowing system with the front mower.
- Sweeping system with the front sweeping machine.
- Snow clearing system with the front sweeping machine or a folding snow blade. A roller spreader as rear attachment. The loading platform is used for holding salt and grit.
- Transport system with the loading platform or trailer operation.
- Wet cleaning system with scrubbing deck, squeegee and trolley.

Your authorised Hako dealer is available to you at all times to answer questions on further applications.



Fig. 1:

Vehicle data

Your vehicle is described clearly by the following data. Please always quote these data in correspondence or when making a telephone query to your authorised Hako dealer or our company.

- Vehicle type: _____
- Chassis No.: _____
- Engine number: _____
- Start-up on: _____

Please enter the data applicable to your vehicle in the list above. The data are immediately available in the case of enquiries or spare parts orders.

Your nearest authorised Hako dealer

- Address: _____

- Telephone: _____

Intended use

The Citymaster 1650 is a multi-purpose machine for commercial and municipal use throughout the year. Using the attachments approved by Hako, the Citymaster 1650 is suitable for cleaning roads and pavements, for transporting items with a trailer and for light winter service. Any use extending beyond this is not intended use. The manufacturer is not liable for any damage resulting from this and the user alone bears the risk. Intended use also includes compliance with the operating, maintenance and servicing conditions specified by the manufacturer in this operating manual.

The vehicle may be used, maintained and repaired only by persons who are familiar with this work and have been instructed and informed about the dangers. Repairs and maintenance work not described in this operating manual may only be carried out by the specialists of a Hako service workshop.

The vehicle and its attachments correspond by virtue of their design and construction as well as in the version distributed by Hako to the usual health and safety requirements of the EC Directives (see Declaration of Conformity and CoC documents). These documents lose their validity in the event of a modification not authorised by Hako. The manufacturer is not deemed liable for any damage resulting from unauthorised modifications to the machine.

Notes on warranty

The terms defined in the purchase agreement apply. Claims for compensation in relation to damage are excluded from the terms of the warranty when the damage is the result of the failure to observe rules concerning servicing and maintenance. Maintenance work must be carried out by a Hako service workshop and confirmed in the service booklet under the item "Maintenance Report", which serves as a warranty logbook.

The following are excluded from the terms of warranty: wear and tear through overuse, defective fuses, improper handling and use and unauthorised modifications. Claims under the terms of the warranty are also annulled when damage occurs to the vehicle resulting from the use of parts or accessories not explicitly approved by Hako or from failure to observe maintenance rules.

Acceptance of the vehicle

Inspect the vehicle immediately on delivery for signs of transport damage. You will be compensated if the damage is immediately confirmed by the haulage contractor and the damage report is sent to our authorised Hako dealer together with the consignment note.

Conditions for approval

The Citymaster 1650 is a multi-purpose machine (tractor for use in agriculture or forestry) within the meaning of Regulation (EU) No. 167/2013. The manufacturer provides an EC Certificate of Conformity.

Based on the EC Certificate of Conformity, the local licensing authorities will produce the registration certificate part 2 (vehicle registration) and part 1 (vehicle registration). For use on public roads, paths and areas the Citymaster 1650 has to be licensed and display an official licence plate. In accordance with the German Road Traffic Approval Order (StVZO), the vehicle must carry a first aid kit, warning triangle, warning light and the vehicle type approval when used on public roads, paths and areas. In Germany, the Citymaster 1650 is subject to regular general inspection according to § 29 StVZO (every 24 months).

Loss of insurance cover

The registration certificate will become void if any modifications or additions are made to the Citymaster 1650 that affect the contents and are not contained in the registration certificate. In consequence, the insurance cover and the vehicle tax will also become void.

After modifying the vehicle, the vehicle must be presented to an officially accepted expert to produce a new report and acquire a new registration certificate. The modifications have to be included in the registration certificate by the registration authorities. In the EC Declaration of Conformity the manufacturer declares that the attachments approved by Hako adhere to the rulings in the EC Directive 2006/42/EC (Machinery Directive).

In other countries, the corresponding national regulations must be complied with.

Driving licence

According to the driving licence law in Germany, the Citymaster 1650 may be driven as a multi-purpose machine (tractor) by drivers with the following classes of driving licence:

Class B:

Motor vehicles - with the exception of motor vehicles in classes AM, A1, A2 and A - with a permissible total weight below 3.5 t, designed and constructed for transporting no more than eight persons in addition to the driver (also with a trailer with a permissible total weight below 750 kg or with a trailer with a permissible total weight above 750 kg, provided that the permissible total weight of 3.5 t of the combination is not exceeded).

In other countries, the corresponding national regulations must be complied with.

Equipment

According to § 35h and § 53a StVZO, the following equipment has to be kept with the vehicle in the Federal Republic of Germany (not included in the scope of supply):

- 1 warning triangle of approved type
- 1 warning light of approved type
- 1 high-visibility vest that complies at least with the requirements of standard sheet EN ISO 20 471 (2013 edition).
- 1 first aid kit that complies at least with the requirements of standard sheet DIN 13 164 (2014 edition).

In other countries, the corresponding national regulations must be complied with.

Required documents

Within the Federal Republic of Germany, the following documents must always be available:

- Approval certificate (Part I) of the vehicle
- Valid driving licence of the driver
- Operating manual (kept in the left-hand operating console)

In other countries, the corresponding national regulations must be complied with.

Vehicle inspection

- All occupational accident insurance schemes in the Federal Republic of Germany require a **safety inspection** of your vehicle according to BGV D 29, which must be made at least once a year by an expert. An inspection label should be attached to the vehicle in addition so that the driver knows when the next expert inspection is due.
- According to § 29 StVZO of the Federal Republic of Germany, a general inspection (**HU**) must be made regularly:
 - For vehicles of less than / equal to 3.5 t permitted overall weight every 24 months (for vehicles which are hired commercially without provision of a driver, 12 months apply).
 - For vehicles of more than 3.5 t permitted overall weight every 12 months.

In other countries, the corresponding national regulations must be complied with.

	Introduction	2
	Foreword	2
	Applications	3
	Vehicle data	4
	Intended use	5
	Notes on warranty	5
	Acceptance of the vehicle	5
	Conditions for approval	5
	Driving license	6
	Equipment	6
	Required documents	6
	Vehicle inspection	6
1	Safety Instructions	10
1.1	Marking of warning and danger symbols	10
1.2	General safety instructions	11
1.3	Operating safety instructions	11
1.4	Safety instructions for attachments	13
1.5	Information about special risks	15
1.6	Safety instructions for maintenance and servicing	16
1.7	Environmental protection instructions	19
1.8	Shutting down and disposal	19
1.9	Labels on the vehicle	20
2	Use.....	24
2.1	Overviews	24
2.1.1	Front view	25
2.1.2	Rear view	27
2.1.3	Driver's cab	29
2.2	Multifunctional display	34
2.2.1	Start screen	34
2.2.2	Menu guidance	34
2.2.3	Menu structure	35
2.2.4	Normal view	36
2.2.5	Working menu (A menu)	37
2.2.6	Operating menu (B menu)	39
2.2.7	Configuration menu (C menu)	41
2.2.8	Warning and information symbols	48
2.3	Controls in the driver's cab	53
2.3.1	Steering column control panel	53
2.3.2	Comfort steering column (optional)	56
2.3.3	Left-hand control panel	59
2.3.4	Right-hand control panel	59
2.3.5	Arm rest control panel	63
2.3.6	Roof control panel	64
2.3.7	Accelerator pedal	65
2.3.8	Brake	65
2.3.9	Coarse material flap	65
2.3.10	Driver's seat	66
2.3.11	Seat belt	68
2.3.12	Cab heating	69
2.3.13	Air conditioning system	70
2.3.14	Doors	71
2.4	Operating equipment of the vehicle	72
2.4.1	Auxiliary tools	72
2.4.2	Ball cock circulating water	72


2.4.3	Front tool carrier	73
2.4.4	Connections for front attachments	77
2.4.5	Connections for rear attachments	79
3	Operation	81
3.1	Instruction	81
3.1.1	Climbing up and down	81
3.2	Before start-up of the vehicle	82
3.2.1	Checklist – Before start-up of the vehicle	83
3.3	Starting and driving the vehicle	87
3.3.1	Starting and driving the vehicle	88
3.3.2	Diesel particle filter	91
3.3.3	Troubleshooting	93
3.4	Shutting down the vehicle	94
3.4.1	Shutting down after the end of work	94
3.4.2	Shutting down in work breaks	94
3.4.3	Shutting down on occurrence of faults	94
3.5	Transporting and towing the vehicle	95
3.5.1	Transporting the vehicle	95
3.5.2	Towing the vehicle	96
3.6	Working with attachments	97
3.6.1	Hako attachments	97
3.6.2	Non-Hako attachments	97
3.6.3	Ballast	98
4	Technical Data	101
5	Maintenance and Servicing	104
5.1	Maintenance plan	105
5.2	Panelling and covers	106
5.2.1	Opening the engine cover, engine flap and side door	106
5.2.2	Removing side paneling	106
5.2.3	Opening the radiator cover	106
5.3	Engine	107
5.3.1	Checking the engine oil level	107
5.4	Fuel system	108
5.4.1	Emptying the water trap	108
5.5	Cooling system	109
5.5.1	Cleaning the cooling system	109
5.5.2	Checking the coolant level	110
5.6	Air filter	111
5.6.1	Checking the air filter	111
5.6.2	Cyclone separator and dust ejection valve	111
5.7	Hydraulic system	112
5.7.1	Important information for using BIO OIL	113
5.7.2	Checking the hydraulic oil level	114
5.8	Driver's cab	115
5.8.1	Changing the cab air filter	115
5.9	Wheels	115
5.9.1	Tyre changing	116
5.10	Electrical system	117
5.10.1	Lamps	117
5.10.2	Fuses and relays	119
5.10.3	Battery	122
5.11	Lubrication plan	124
5.12	Cleaning the vehicle	125
5.12.1	General notes	125


6	Attachments and Options.....	127
6.1	Vacuum sweeping system	128
6.1.1	Labels on the unit	129
6.1.2	Vacuum sweeping system safety instructions	129
6.1.3	Mounting	130
6.1.4	Operation	138
6.1.5	Technical data	157
6.1.6	Maintenance	160
6.1.7	Troubleshooting	169
6.1.8	Accessories	169
6.2	Lawn mowing system	170
6.2.1	Labels on the unit	171
6.2.2	Lawn mowing system safety instructions	171
6.2.3	Mounting	172
6.2.4	Operation	173
6.2.5	Technical data	177
6.2.6	Maintenance	178
6.2.7	Troubleshooting	180
6.2.8	Accessories	180
6.3	Sweeping system	181
6.3.1	Labels on the unit	182
6.3.2	Sweeping system safety instructions	182
6.3.3	Mounting	183
6.3.4	Operation	184
6.3.5	Technical data	187
6.3.6	Maintenance	187
6.3.7	Troubleshooting	189
6.3.8	Accessories	189
6.4	Snow clearing system	190
6.4.1	Labels on the unit	191
6.4.2	Snow clearing system safety instructions	191
6.4.3	Mounting	192
6.4.4	Operation	197
6.4.5	Technical data	200
6.4.6	Maintenance	200
6.4.7	Accessories	200
6.5	Transport system	201
6.5.1	Labels on the unit	202
6.5.2	Safety instructions	202
6.5.3	Mounting	202
6.5.4	Operation	204
6.5.5	Technical data	205
6.5.6	Maintenance	205
6.5.7	Accessories	205
6.6	Wet cleaning system	206
6.6.1	Labels on the unit	207
6.6.2	Mounting	207
6.6.3	Operation	213
6.6.4	Technical data	221
6.6.5	Maintenance	222
6.6.6	Troubleshooting	228
6.6.7	Accessories	228


1 Safety Instructions


1.1 Marking of warning and danger symbols


Important tasks concerning the safety of the operator and vehicle are named as follows in this operating manual and emphasised by symbols:


	Danger Indication of a direct danger with high risk, in which death or severe physical injury can occur if it is not avoided.
---	---

	Warning Indication of a possible danger with average risk, in which death or severe physical injury can occur if it is not avoided.
---	---

	Caution Indication of a danger with low risk, in which light to medium severe physical injury or material damage can occur if it is not avoided.
---	--

	Attention Attention indicates a hazard that can lead to technical damage when not heeded.
--	---

	Environmental danger Environmental danger due to the use of substances from which a health and environmental risk proceeds.
---	---

	Note Indication of information that facilitates more effective and economical use of the vehicle.
---	---

1.2 General safety instructions

- Apart from the instructions in this operating manual, the general safety and accident prevention regulations of the legislation must be taken into account.
- Before the vehicle is put into service, please read carefully the operating manual you receive as well as further separate instructions for additional implements or attachments and observe them in all aspects in your work.
- The vehicle may be used, maintained and repaired only by persons who have been instructed by Hako experts.
- This device may not be used by persons (including children) with reduced physical or mental abilities or by persons without sufficient experience and skills.
- You should pay special attention to the safety instructions. For errors in operating the vehicle can be avoided and trouble-free operation can be guaranteed only with precise factual knowledge.
- Please hand over these documents as well as the approval documents to the new owner/operator on sale or rental of the vehicle. Have the hand-over confirmed!
- The labels attached to the vehicle provide important information for safe operation. Renew labels that are no longer legible or present.
- The approval certificate (Part 1), valid driver's license of the vehicle driver and the operating manual must be present constantly at the place of use of the vehicle and should therefore be kept carefully in the driver's cab.
- Spare parts must be original spare parts to guarantee safety.
- The Citymaster 1650 is equipped with a safety cab (ROPS – roll-over protection system) according to 86/298/EEC.

1.3 Operating safety instructions

Before putting into service

- Risk of accident! If the steering column is unlocked while driving, it can come unexpectedly out of adjustment. You can then lose control over the vehicle.
- Risk of accident! Adjust the driver's seat only when the vehicle is stationary. You will otherwise be diverted from the traffic and could lose control over the vehicle by moving the seat. You could cause an accident by this.
- Risk of accident! A dirty, damaged seat belt or one stressed or changed in an accident may not offer the intended protection. You could therefore suffer severe injuries or death in an accident. Please check regularly that the seat belts are not damaged and not contaminated. Always have damaged seat belts or those stressed in an accident renewed by an authorised workshop.
- Risk of accident! Good viewing conditions contributing to traffic safety are guaranteed only if all windows are free of ice, snow and condensation. Make yourself familiar with the correct operation of the heating and ventilation system as well as de-moisturising/defrosting the windows. Maximum heating power and fast thawing of the windows can be achieved only if the engine has reached its operating temperature.
- There is a risk of accidents when driving with open doors! The doors must remain closed when driving on public roads and when working.
- Check the vehicle for its correct condition and operating safety before using it. The vehicle must not be used if it is not in order.
- Before starting work, the operator must familiarize himself with all equipment, operating and actuating elements as well as with their function. It is too late to do this during operation!
- A warning triangle, a warning light, a warning vest and a first aid kit must be in the vehicle during operation.
- Sturdy and slip-proof shoes must be worn when working with the vehicle.
- This device may not be used by persons (including children) with reduced physical or mental abilities or by persons without sufficient experience and skills.
- Carrying persons is not permitted!
- Only those surfaces approved by the contractor or its authorised representative for use of the vehicle may be driven on.
- The vehicle is not suitable for removing dangerous, combustible or explosive liquids, dusts or materials.
- Observe the maximum gradability of the vehicle, see Technical data.

During operation

- Toxic engine exhaust gases! Inhaling exhaust gases is injurious to health and can lead to unconsciousness and to death! Never let the engine run in enclosed spaces.
- Danger to life in the danger area of the vehicle! Special caution is required in the vicinity of the articulated steering, under the raised tipper, in the vicinity of the front tool carrier, in the vicinity of the front and rear-mounted equipment and in the area between the vehicle and the trailer.
- Danger of tilting over when driving uphill or downhill and transversely to a slope! Avoid sudden turns when driving uphill or downhill or across slopes. There is a risk of tilting over on slopes of more than 20% with a loaded vehicle! The vehicle speed must always be adapted to the surrounding conditions and the load condition.
- Danger of tilting due to wrong steering! Note that the steering behaviour of an articulated steered vehicle differs essentially from that of a car. Sudden steering movements at high speed or too high speeds when turning can cause the vehicle to tilt over.
- Risk of accident! Note that there is a risk of skidding on unpaved ground or snow and ice. This can lead to uncontrolled behaviour of the vehicle. Drive correspondingly carefully!
- Risk of accident! Note that dirty pedals can impair the braking effect!
- Risk of accident! When operating at special altitudes (above 3,000 metres), the power of the engine or the engine brake decreases. Adapt your mode of operation and driving style accordingly.
- Risk of accident! Use the cruise control and the speed limiter only when the traffic situation allows!
- For reasons of safety, the vehicle is equipped with a seat contact switch and the function of the seat contact switch must not be bypassed.
- In the case of restricted vision, especially when reversing the vehicle, it is necessary to have a second person who gives the driver appropriate signals. The second person must always be in the field of view of the driver.
- When working with the vehicle, pay special attention to third persons, especially children.
- Persons with a disturbed sensation of heat should only operate the seat heating (optional) in stage I.
- In transport journeys on public roads the working lights must be switched off.

Shutting down the vehicle

- Risk of accident! Adopt measures against erroneous starting and unwanted movement. Engage the parking brake. Switch the engine off and pull out the ignition key.
- Risk of accident! The vehicle must be parked on firm ground. On inclinations secure the vehicle additionally against rolling away with a wheel chock.

Transporting and towing the vehicle

- Danger to life! Start driving slowly! Make sure that there are no persons in the towing area.
- Risk of injury! The vehicle may be loaded only using suitable loading aids, such as a loading ramp or drive-up planks.
- Risk of injury! After loading, make sure that the vehicle is secured according to regulations against rolling off and tilting. Use the wheels for securing the vehicle.
- Tow the vehicle using only suitable towing gear!
- The vehicle may be towed with a towing rope only if the brakes and steering are functioning!
- When the engine is still the steering has only emergency steering properties!
- Secure the vehicle against unintended movement! Engage the parking brake and insert the locking bolt on the articulated joint. Note that the steering is then blocked!

1.4 Safety instructions for attachments

General

- Danger to life in the danger area of the vehicle! Special caution is required in the vicinity of the articulated steering, under the raised tipper, in the vicinity of the front tool carrier, in the vicinity of the front and rear-mounted equipment and in the area between the towing vehicle and the trailer.
- Risk of injury! Put the attachment into service only if all protective devices are attached and in protection position.
- Risk of injury! Make sure that the attachments are suitable for the set oil volume. An oil volume set too high can lead to injuries due to a defect of the attachment!
- Risk of injury! High-pressure hoses, fittings and couplings are important for equipment safety. Use only high-pressure hoses, fittings and couplings recommended by the manufacturer.
- Risk of accident! When connecting attachments to the hydraulic system, ensure that the hydraulic hoses are connected correctly. Swapping the connections can lead to reverse functioning of the attachment, e.g. movement to the right rather than the left.
- Risk of accident! Front attachments not correctly fastened to the front tool carrier can drop down while driving. Always secure the front attachment with the locking devices.
- Risk of accident! You must consult Hako before attaching other attachments not approved by Hako! Check in the individual case that the relevant axial loads and total weights are complied with.
- Risk of accident! Handling, steering and braking as well as stability are influenced by attachments, trailers and the vehicle payload (e.g. full dirt hopper). For this reason, pay attention to adequate steering and braking capability as well as stability.
- Risk of accident! In Germany, if attachments extend beyond the outer lighting equipment of the vehicle or if the maximum distances of the outer lighting equipment specified according to StVZO are exceeded, the lighting equipment of the vehicle must be repeated (see Merkblatt StVZO § 30, explanations 11 and 12).

Ballast

- Risk of accident! When attaching other devices not approved by Hako, check in the individual case whether the relevant axle loads and total weights are complied with!
- Risk of accident! The front axle of the working machine must always be loaded with at least 25% of the empty weight and the rear axle with at least 37% of the empty weight of the working machine.
- Risk of accident! The attachment of front and rear attachments must not lead to exceeding the permissible total weight, the permissible axle load and the tyre load capacity of the working machine!
- Make sure before purchasing the attachment that these requirements are fulfilled by weighing the working machine attachment combination!

Vacuum sweeping system

- Danger to life in the danger area of the vehicle! Special caution is required under the raised tipper and in the area of the sweeping unit.
- Danger of tilting over when driving uphill or downhill and transversely to a slope! Avoid sudden turns when driving uphill or downhill or across slopes. There is a risk of tilting over on slopes of more than 20% with a loaded vehicle! The vehicle speed must always be adapted to the surrounding conditions and the load condition.
- Danger of tilting due to wrong steering! Note that the steering behaviour of an articulated steered vehicle differs essentially from that of a car. Sudden steering movements at high speed or too high speeds when turning can cause the vehicle to tilt over.
- Risk of injury! Frequently check the filling level of the dirt hopper. Switch the suction fan off for this! The lid and the side doors of the dirt hopper must not be opened when the suction fan is running.
- Risk of accident! Make transport journeys only with the sweeping unit raised and secured in the transport position.
- Risk of accident! Make transport journeys only with a completely lowered dirt hopper!
- Risk of accident! The stability of the vehicle is influenced by a filled dirt hopper. Handling of the vehicle must be adapted accordingly.
- Risk of accident! Do not exceed the permissible total weight of the vehicle!
- Risk of accident! When the dirt hopper is emptied, the Citymaster 1650 must be on a sufficiently load bearing, horizontal surface. Driving with the dirt hopper tilted is not permitted.

- When removing blockages in the suction hose or attaching the hand suction hose (optional), switch off the engine and wait for the suction fan to come to a standstill.
- The vacuum sweeping system may be operated only in connection with the Citymaster 1650. The safety regulations for the Citymaster 1650 must be complied with absolutely.

Lawn mowing system

- Danger to life in the danger area of the vehicle! Special caution is required under the raised tipper and in the area of the front mower.
- Risk of injury! Make sure that the attachments are suitable for the set oil volume. An oil volume set too high can lead to injuries due to a defect of the attachment!
- Risk of injury! Always wear protective gloves when changing blades!
- Risk of injury! Immediately renew damaged or highly unbalanced mowing blades to avoid damage to the blade bearings.
- Risk of injury! Before reinstalling, balance the blades and check them for out of true in height.
- Risk of injury! The V-belt is self-tensioning by spring force. Do not hook tension springs in or out with your bare hand.
- Risk of injury! Do not exceed the permissible total weight. There is a risk of accidents! Frequently check the filling level of the dirt hopper. Switch the suction fan off for this! The lid of the dirt hopper must not be opened when the suction fan is running.
- Risk of injury! Modifying the safety equipment is not permitted!
- Risk of accident! You must consult Hako before attaching other attachments not approved by Hako!
- The lawn mowing system may be put into operation only with the suction nozzles raised! See mounting the mower on page 170!
- The lawn mowing system may be operated only in connection with the Citymaster 1650. The safety regulations for the Citymaster 1650 must be complied with absolutely.

Sweeping system

- Danger to life in the danger area of the vehicle! Special caution is required in the area of the articulated steering, under the raised tipper and in the area of the front sweeping roller.
- Risk of injury! When sweeping with the front sweeping machine, small stones or other parts in the snow can be thrown out by the rotating sweeping roller.
- Risk of injury! Secure the front sweeping machine against rolling away when mounting it.
- The sweeping system may be operated only in connection with the Citymaster 1650. The safety regulations for the Citymaster 1650 must be complied with absolutely.

Snow clearing system

- Danger to life in the danger area of the vehicle! Special caution is required in the area of the articulated steering, under the raised tipper and in the area of the front and rear attachment.
- Risk of accident due to unintended lowering of the attachment! Activate winter operation in the configuration menu only in connection with an uncoded snow blade. The front lift is then not limited downwards. Winter operation must be deactivated immediately after use.
- The snow clearing system may be operated only in connection with the Citymaster 1650. The safety regulations for the Citymaster 1650 must be complied with absolutely.

Transport system

- Danger to life in the danger area of the vehicle! Special caution is required in the vicinity of the articulated steering, beneath the raised tipper and in the area between the towing vehicle and the trailer.
- Danger to life due to inadequately secured load! The load must be correctly distributed and fastened on the loading surface.
- Risk of injury! Modifying the safety equipment is not permitted!
- Risk of accident! Adopt measures against erroneous starting and unwanted movement. Switch the engine off and pull out the ignition key.
- Risk of accident! You must consult Hako before attaching other attachments not approved by Hako!
- The transport system may be operated only in connection with the Citymaster 1650. The safety regulations for the Citymaster 1650 must be complied with absolutely.

Wet cleaning system

- Danger to life in the danger area of the vehicle! Special caution is required in the vicinity of the articulated steering and beneath the raised tipper.
- Risk of injury! Modifying the safety equipment is not permitted!
- Risk of accident! Adopt measures against erroneous starting and unwanted movement. Switch the engine off and pull out the ignition key.
- Risk of accident! You must consult Hako before attaching other attachments not approved by Hako!
- Risk of crushing! The squeegee of the CityCleaner weighs more than 25 kg. Body parts may be crushed if the squeegee falls down or falls over. Always use suitable load-carrying equipment.
- Risk of injury! Wear suitable protective clothing (protective gloves and safety goggles) when using detergents.
- Risk of injury! There is a risk of tilting over if the squeegee is located on the trolley without the scrubbing deck. Observe the correct assembly and disassembly sequence.
- Risk of injury! Always wear protective gloves when working on the lateral deflectors and brushes.

1.5 Information about special risks

Electric energy

- When working with the vehicle, maintain a safe distance from overhead electric cables. When working close to overhead electric cables, the equipment/attachments must not come into the vicinity of these cables. Danger to life! Familiarise yourself with the prescribed safety distances.
- Lightning can cause severe or fatal injury. Do not use the machine if you see lightning or hear thunder.

Exhaust gases

- Toxic engine exhaust gases! Inhaling exhaust gases is injurious to health and can lead to unconsciousness and to death! Never let the engine run in enclosed spaces.

Re-fuelling the vehicle

- Risk of fire! Diesel fuel is flammable! Take the utmost care when handling fuel. Never refuel close to naked flames or ignitable sparks. Do not smoke during fuelling. Switch off the engine, pull out the ignition key and engage the parking brake before fuelling.

Danger areas at the vehicle

- Danger to life in the danger area of the vehicle! Special caution is required in the vicinity of the articulated steering, under the raised tipper, in the vicinity of the front tool carrier, in the vicinity of the front and rear-mounted equipment and in the area between the towing vehicle and the trailer.

Danger of tilting over

- Danger of tilting over when driving uphill or downhill and transversely to a slope! Avoid sudden turns when driving uphill or downhill or across slopes. There is a risk of tilting over on slopes of more than 20% with a loaded vehicle! The vehicle speed must always be adapted to the surrounding conditions and the load condition.
- Danger of tilting due to wrong steering! Note that the steering behaviour of an articulated steered vehicle differs essentially from that of a car. Sudden steering movements at high speed or too high speeds when turning can cause the vehicle to tilt over.

Unsecured load

- Danger to life due to inadequately secured load! The load must be correctly distributed and fastened on the loading surface.

Suspended loads

- Danger to life due to suspended loads! Do not stay or work under suspended loads!

Battery

- Danger of explosion due to smoking, fire or open light! Especially when being charged, but also in the normal use of batteries, batteries emit explosive gases! Avoid smoking, fire, sparks or open light in the vicinity of batteries!

- Danger of explosion due to sparks! Never place tools or other electrically conductive objects on the battery! Sparks that can ignite escaping gases arise if the poles are short-circuited. Always observe the correct order when connecting and disconnecting the battery!
 - Disconnecting the battery: first the minus pole and then the plus pole!
 - Connecting the battery: first the plus pole and then the minus pole!
- Danger of explosion due to frozen battery or too low acid level! With a frozen battery or if the acid level is too low, do not attempt to start with a jumper cable, the battery can burst or explode.
- Danger of burns due to battery acid! The special safety and accident prevention regulations must be complied with when handling the battery. Batteries contain sulphuric acid.

Noise

- Danger of injury due to noise! Sound insulation devices on the vehicle must be in their protection position during operation. If required, wear hearing protectors!

Hydraulics

- Risk of injury! Hydraulic oil issuing under high pressure can penetrate the skin and cause severe injuries. Therefore, even with the smallest wounds, consult a doctor since otherwise severe infections can arise!
- Hydraulic pipes must be run and installed correctly! The work may be done only by authorised skilled persons. Make sure that no connections are mixed up! Fittings, length and quality, especially resistance to pressure and temperature of hydraulic pipes, must comply with the requirements.

Operating and auxiliary materials

- Risk of injury! Observe the safety regulations applicable for the product when handling oils, greases and other chemical substances (e.g. battery acid or sulphuric acid)!
- There is a risk of burns and scalds! Caution when handling hot operating and auxiliary materials.

1.6 Safety instructions for maintenance and servicing

General

- Daily and weekly maintenance work can be done by the operating staff. In all other maintenance work, see service booklet, please contact your nearest authorised Hako dealer. Any warranty claim is null and void if this is not complied with and damage results.
- Apart from the regular general inspection (HU), the vehicle, the attachments and the trolley must be maintained at regular intervals according to BGV, D 29 and be checked at least annually for operationally safe condition.
- Risk of accident! Adopt measures against erroneous starting and unwanted movement. Engage the parking brake. Switch the engine off and pull out the ignition key.
- Spare parts must be original spare parts to guarantee safety.
- Use suitable tools for the cleaning and maintenance work.
- Cleaning the electrical and electronic components as well as the engine space with a high-pressure cleaner or steam cleaner is not allowed.
- Do not perform any welding, drilling, sawing or grinding work on parts of the frame. Damaged parts may be replaced only by your authorised Hako dealer.
- After cleaning, examine all fuel, engine oil and hydraulic pipes for leaks, abrasion places and damage. Immediately rectify any damage found!
- Always tighten screw connections loosened in maintenance and repair work.
- If dismantling safety devices is required in equipping, maintenance and repair work, fit and check the safety devices immediately after completion of the work.
- Perform maintenance and repair work under a jacked up vehicle or attachment only if it is safely and securely supported (hydraulic cylinders, jacks, etc. alone do not secure a jacked-up vehicle).

Engine

- Toxic engine exhaust gases! Inhaling exhaust gases is injurious to health and can lead to unconsciousness and to death! Never let the engine run in enclosed spaces.

- Danger of burns from hot parts! Do not touch any parts such as engine block, cooling system and exhaust system during operation and for some time after. Let the engine cool down.
- Risk of scalding from hot engine oil! If the cap is opened when the engine is hot, there is a risk of scalding. Let the engine cool down.
- Risk of injury due to rotating parts! Injury of limbs or hair or clothing getting caught up. Switch the engine off and pull out the ignition key.
- If the engine oil pressure warning symbol in the multifunctional display lights up with the engine running, there is a risk of engine damage! Stop the vehicle in the safe area. Turn the engine off immediately and check the oil level. Have the cause of the inadequate engine oil pressure removed.
- If the diesel particulate filter symbol in the multifunctional display lights up red, the vehicle engine must be switched off immediately. Serious engine damage can be caused if this is not complied with.

Fuel system

- Risk of fire! Diesel fuel is flammable! Take the utmost care when handling fuel. Never refuel close to naked flames or ignitable sparks. Do not smoke during fuelling. Switch off the engine, pull out the ignition key and engage the parking brake before fuelling.
- Danger of burns from hot parts! Do not touch any parts such as engine block, cooling system and exhaust system during operation and for some time after. Let the engine cool down.
- There is a risk of engine damage if the fuel system is run completely empty! Inform an authorised workshop!

Diesel particle filter

- Danger of fire and burning! The diesel particulate filter gets very hot. Do not grasp in the area of the diesel particulate filter. Do not park the vehicle in the direct vicinity of flammable substances.

Cooling system

- Danger of burns from hot parts! Do not touch any parts such as engine block, cooling system and exhaust system during operation and for some time after. Let the engine cool down.
- Risk of scalding from hot coolant! The cooling system is under pressure. If the cooling system cap is opened with a hot engine there is a risk of scalding. Let the engine cool down.
- Risk of injury due to rotating parts! Injury of limbs or hair or clothing getting caught up. Switch the engine off and pull out the ignition key.
- The cooling fins are very thin and can be damaged easily.
- Small air bubbles can form when the radiator is filled. Therefore the cooling system must be vented at the same time. Have this done by an authorised workshop!

Air filter

- Danger of burns from hot parts! Do not touch any parts such as engine block, cooling system and exhaust system during operation and for some time after. Let the engine cool down.
- We can assume no liability for the cleaned filter insert. Never let the engine run without a filter insert!
- Only replace the safety cartridge, do not clean it! Never let the engine run without safety cartridge!

Hydraulic system

- Risk of injury from hydraulic oil! Hydraulic oil issuing under high pressure can penetrate the skin and cause severe injuries. Therefore, even with the smallest wounds, consult a doctor since otherwise severe infections can arise!
- Danger of burns from hot parts! Do not touch any parts such as engine block, cooling system and exhaust system during operation and for some time after. Let the engine cool down.
- Work on the hydraulic system of the vehicle may be done only by persons with special knowledge and experience in hydraulics.
- Regularly check all pipes, hoses and screw connections for leaks and external visible damage. Immediately rectify damage and leaks. Oil squirting out can cause injuries and fires. Observe the recommended replacement intervals for hydraulic pipes. Replace hydraulic hose lines every five years from the date of manufacture, even if they do not seem to be damaged!
- Hydraulic hose lines must always be attached in the correct location! Fittings and the length and quality of the hose line must comply with the requirements.

Air conditioning system

- Risk of injury! The coolant in the air conditioning system is under high pressure. Do not open any parts of the air conditioning system. Have maintenance work on the air conditioning system done only by authorised workshops.
- Danger of burns from hot parts! Do not touch any parts such as engine block, cooling system and exhaust system during operation and for some time after. Let the engine cool down.

Wheels

- Risk of accident! Repair work on tyres and rims may be undertaken only by skilled personnel or authorised workshops.
- When changing wheels, make sure that the jack is applied to the specified jacking point.
- Damaged tyres and/or incorrect tyre pressure reduce the operational safety of the vehicle. There is a risk of an accident with tyres with too low or too high tyre pressure!
- Check the wheel nuts regularly for firm seating. After a tyre change check the wheel nuts after 50 km and tighten them if necessary.

Electrical system

- Danger of explosion due to smoking, fire or open light! Especially when being charged, but also in the normal use of batteries, batteries emit explosive gases! Avoid smoking, fire, sparks or open light in the vicinity of batteries!
- Danger of explosion due to sparks! Never place tools or other electrically conductive objects on the battery! Sparks that can ignite escaping gases arise if the poles are short-circuited. Always observe the correct order when connecting and disconnecting the battery!
 - Disconnecting the battery: first the minus pole and then the plus pole!
 - Connecting the battery: first the plus pole and then the minus pole!
- Danger of explosion due to frozen battery or too low acid level! With a frozen battery or if the acid level is too low, do not attempt to start with a jumper cable, the battery can burst or explode.
- Danger of burns due to battery acid! The special safety and accident prevention regulations must be complied with when handling the battery. Batteries contain sulphuric acid.
- Work on the electrical system may be done only in accordance with electrical engineering standards by a specialist trained for this work.
- Regularly inspect/check the electrical equipment of the vehicle. Defects such as loose connections or scorched cables must be removed immediately.
- Note the operating voltage of the vehicle!
- Use only original fuses. If stronger fuses are used, the electrical system can be destroyed and there can be fires.
- Welding work on the vehicle may be done only by authorised Hako dealers. Welding work on the vehicle leads to damage to the control electronics and can impair driving safety.

Installation of electrical devices

- The vehicle is equipped with electronic components and parts whose function can be influenced by electromagnetic emissions of other devices. Such influence can lead to danger to persons and safety-relevant functions if the following safety instructions are not complied with:
- If electrical and electronic devices and/or components, which also are connected to the vehicle electrical system, are installed subsequently in the vehicle, the user must examine in his own responsibility whether the installation causes interference to the vehicle electronics or to other components, a renewed acceptance test may be necessary.
- Above all it must be ensured that the subsequently installed electrical and electronic components comply with the EMC Directive 2004/108/EC in the relevant valid edition and bear the CE marking or an E1 approval is available.
- In addition, the following requirements especially must be fulfilled for the subsequent installation of mobile communication systems (e.g. radio, telephone):
 - Only devices with approval according to the valid national regulations (e.g. BZT approval in the Federal Republic of Germany) may be installed.
 - The device must be installed permanently.



- Operation of portable or mobile devices inside the vehicle is permitted only through a connection to a permanently installed outside antenna.
- The transmitter must be installed in a separate location from the vehicle electronics.
- When installing the antenna, pay attention to correct installation with good ground connection between antenna and vehicle ground.

1.7 Environmental protection instructions

- Adequate knowledge is required for the safe handling of substances which could represent a risk to health and the environment.
- Observe the applicable laws and local regulations when disposing of detergents.
- During maintenance work and repairs, operating substances and filters have to be collected in suitable containers and properly disposed of observing the applicable laws and local regulations.
- Leaked oil, diesel fuel and lubricants etc. must not enter into the soil. Otherwise this would create a serious risk of groundwater contamination.
- Any contamination from leakages has to be cleared up without delay and disposed of properly. Used filters usually have to be disposed of as special waste (e.g. fuel filters) depending on the filtered substance.
- Ensure safe and environment-conserving disposal of operating and auxiliary materials. Take up escaping or spilled operating materials in suitable containers and dispose of them in an environmentally friendly manner.
- Used batteries with the recycling symbol contain reusable commodities. In accordance with the symbol showing the crossed-out garbage bin, these batteries must not be disposed of in the domestic waste. Return and recycling have to be arranged with the authorised Hako dealer as required in § 6 and § 8 of the German battery law (BattG)!

1.8 Shutting down and disposal

If the end of use of the vehicle or of its components is reached and this is handed over for scrapping, the components must be correctly disposed of. Here the regulations of the competent local authorities must be observed. The operating materials in the vehicle require special disposal and may not get into the environment. Further information about disposal is available through the competent local authorities and the authorised Hako dealer.

- Do not dispose of products with the symbol  at the end of their life in the domestic waste.
- Recycle used materials with the symbol  according to their labelling.
- Recycle packaging materials and do not throw them into the domestic waste.
- Recycle plastics that are identified with statement of the material, such as PPTV20 for example, and do not throw them into the domestic waste.
- Old batteries contain hazardous materials and must be returned to the distributor, disposed of correctly or delivered to a collecting point. Do not throw old batteries into the domestic waste.
- Treat operating materials such as oils, hydraulic fluids or fuels as hazardous waste and dispose of them correctly.
- Have refrigerants disposed of only by specialist firms with expert staff and the required technical equipment. Refrigerant may under no circumstances get into the atmosphere. Have refrigerants disposed of by an authorised Hako dealer.
- Observe national regulations.

1.9 Labels on the vehicle

The following safety and instruction labels are affixed well legibly to the vehicle. Renew missing or illegible labels immediately.

A

B

C

D

	T-1	T-2	T-3
B-1	---	---	---
B-2	---	---	---
B-3	---	---	---
B-4	---	---	---

E

Bereifung Tyre	Luftdruck v / h Pressure f / r

F

G

Citymaster 1650

H

I

Achtung!
Vor Verlassen des Fahrersitzes
Handbremse betätigen.
Caution!
Engage the parking brake before
leaving the seat.

J

K

Fig. 2:

Hako company logo Fig. 2-A

The Hako company logo (147 mm x 40 mm) is located on the left and right cover of the engine.
The Hako company logo (220 mm x 60 mm) is located on the windscreen.

Label – High-pressure cleaner Fig. 2-B

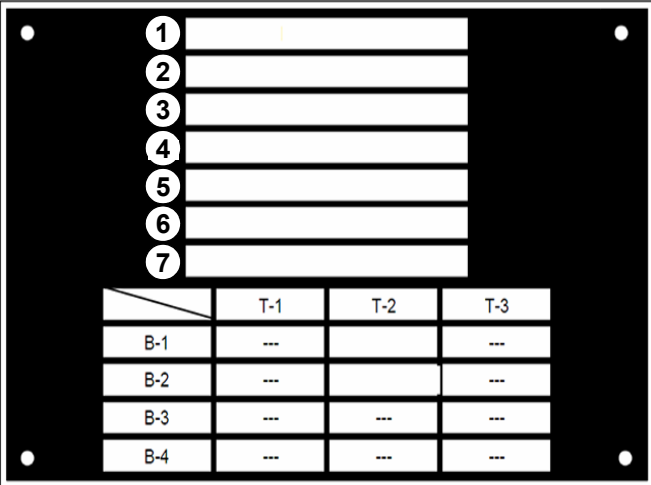
The High-pressure cleaner label is located in the driver's cab under the driver's seat.

Label – Noise measurements Fig. 2-C

The Noise measurements label is located in the driver's cab under the driver's seat.

Label – Type plate Fig. 2-D

The Type plate label is located in the driver's cab under the driver's seat.
Field designations:

	1	Name of manufacturer		
	2	Class and sub-class		
	3	EC type approval number		
	4	Vehicle identification number		
	5	Permissible gross weight		
	6	Max. front axle load		
	7	Max. rear axle load		
		T-1	T-2	T-3
B-1	---			---
B-2	---			---
B-3	---	---	---	---
B-4	---	---	---	---
B-1	Trailer without brakes	T1	Drawbar trailer	
B-2	Trailer with overrun brakes	T2	Rigid drawbar	
B-3	Hydraulic brake	T3	Central axle trailer	
B-4	Pneumatic brake			

Label – Tyre pressure Fig. 2-E

The Tyre pressure label is located in the driver's cab under the driver's seat.

Label – Operating manual Fig. 2-F

The Operating manual label is located in the driver's cab on the front bar top right.

Label – Machine type Fig. 2-G

The Machine type label is located on both driver's doors.

Label – Emergency steering Fig. 2-H

The Emergency steering label is located in the driver's cab on the steering column.

Label – Parking brake Fig. 2-I

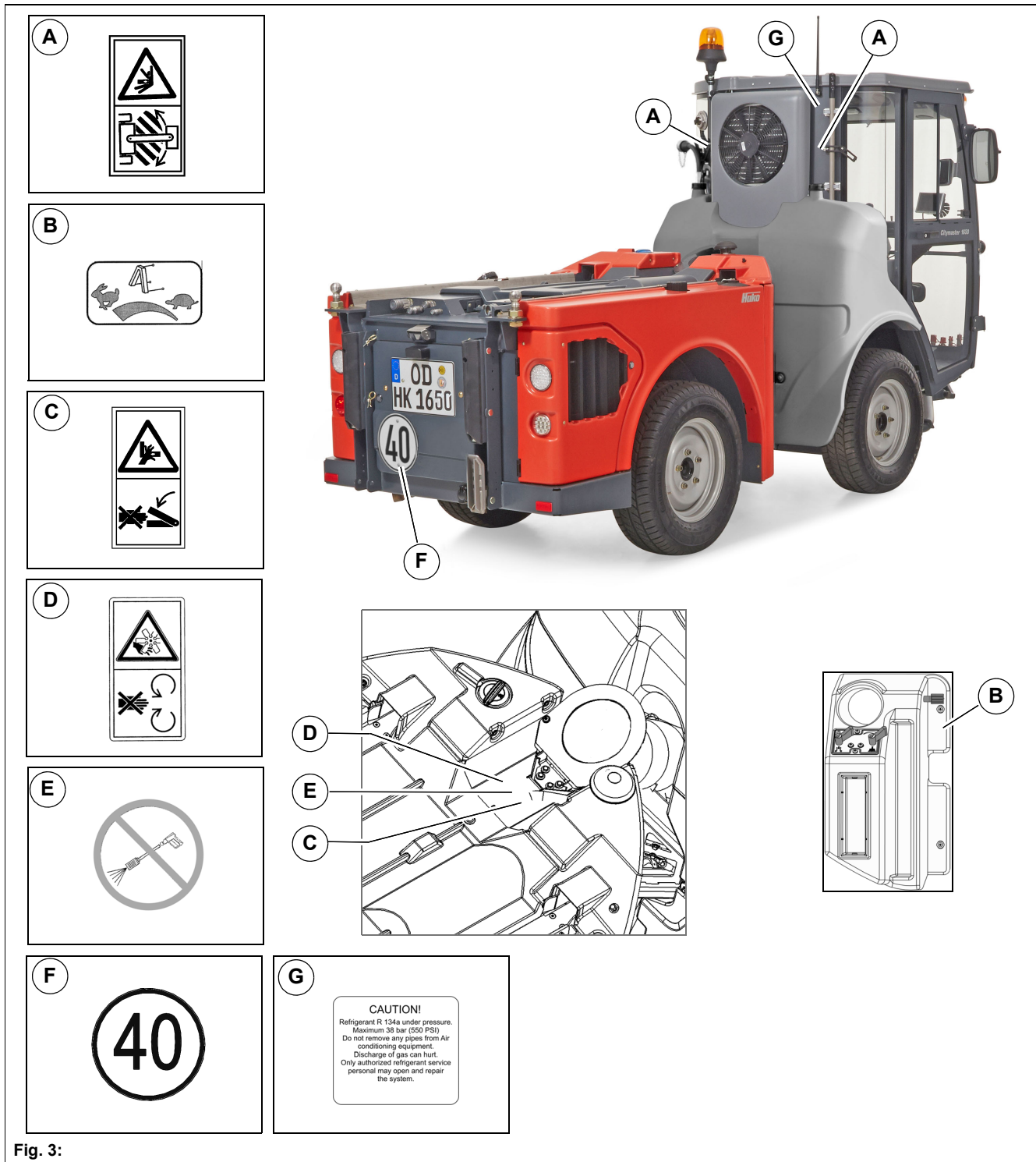
The Parking brake label is located in the driver's cab on the steering column.

Label – Suction mouth Fig. 2-J

The Suction mouth label is located behind the front tool carrier.

Label – AGR Fig. 2-K

The AGR label is located on the window of the driver's cab.



Labels – Danger in articulation area Fig. 3-A

The Danger in articulation area labels are located on the driver's cab at the rear on the left and right.

Label – Front tool carrier lowering valve Fig. 2-B

The Front tool carrier lowering valve label is located on the left control panel.

Labels – Risk of crushing Fig. 3-C

The Risk of crushing labels are located on the rear wagon on the left and right next to the suction pipe.

Label – Rotating parts Fig. 3-D

The Rotating parts label is located on the rear wagon on the left next to the suction pipe.

Label – High-pressure cleaner Fig. 3-E

The High-pressure cleaner label is located on the rear wagon on the right next to the suction pipe.

Label – Allowed maximum speed Fig. 3-F

Allowed maximum speed of the vehicle in km/h. The Allowed maximum speed label is located at the driver's cab at the rear on the right.

Label – Air-conditioner Fig. 3-G

The Air-conditioner label is located at the driver's cab at the rear on the right.

2 Use

2.1 Overviews

The description in chapter 2 contains information on the function and handling of the individual controls on the vehicle. The controls always have the same item number in all chapters.

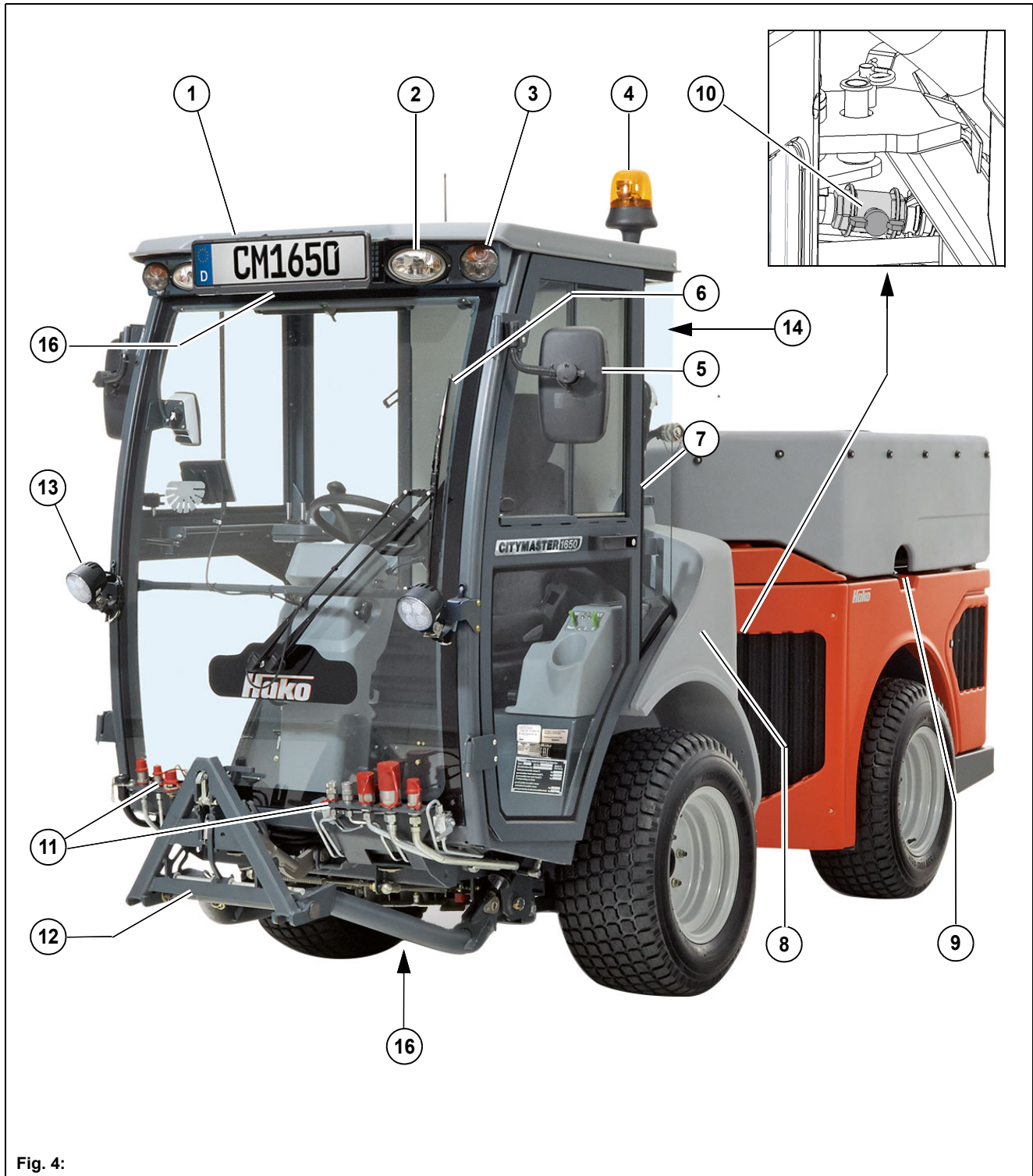


Fig. 4:

2.1.1 Front view

Item	Designation
1	Driver's cab
2	Dipped headlight
3	Direction indicator (front) with side lights
4	Rotating beacon
5	Outside mirror (optionally heated)
6	Windscreen wiper
7	Doors
8	Fresh water tank
9	Fuel tank
10	Ball cock circulating water
11	Front attachment connections
12	Front tool carrier
13	Front cab working light
14	Rear cab working light (optional)
15	Suction mouth working light (optional)
16	Number plate holder

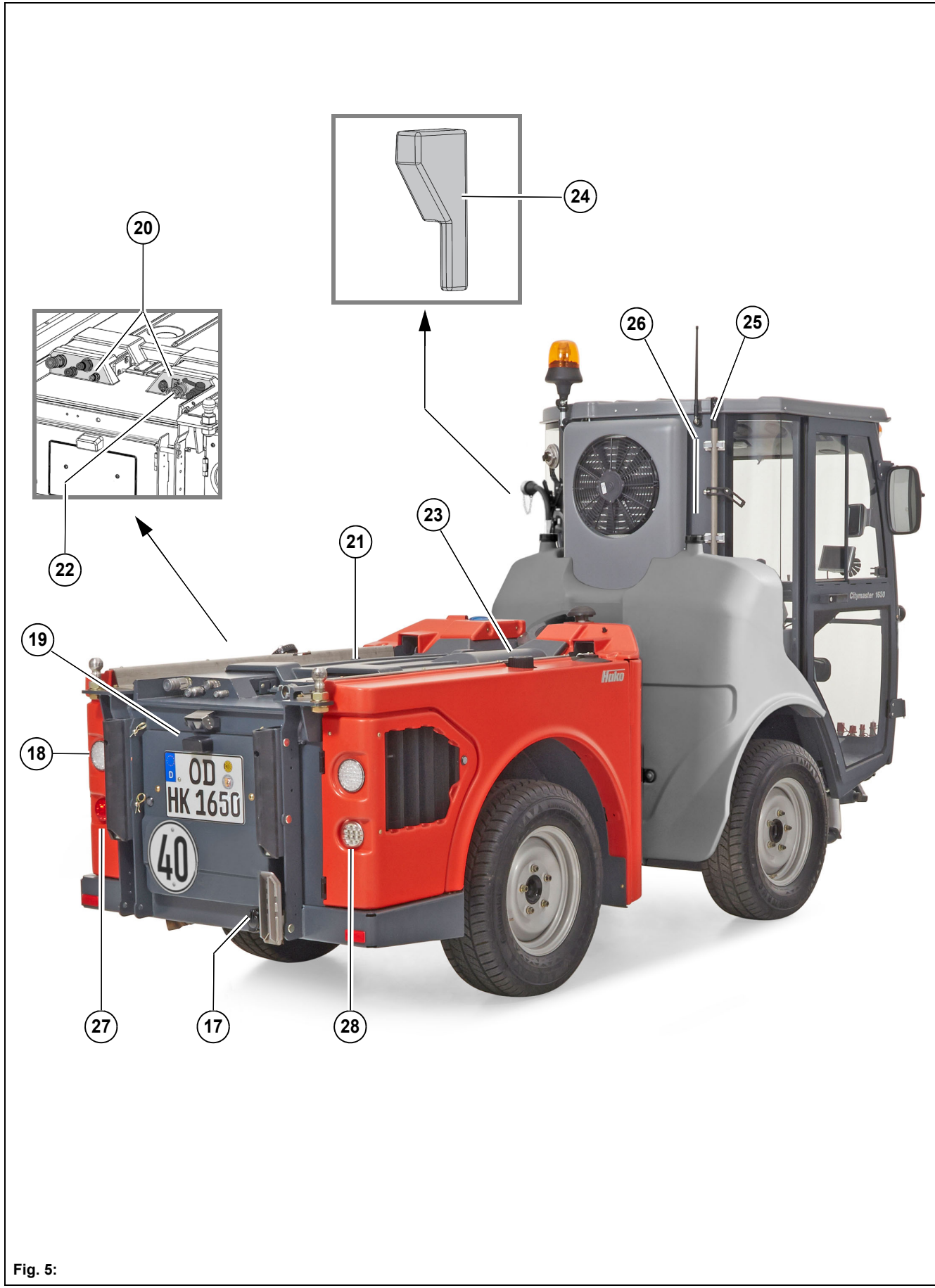


Fig. 5:

2.1.2 Rear view

Item	Designation
17	7-pin socket for trailer operation
18	Direction indicator with rear light and brake light
19	Number plate light
20	Rear attachment connections
21	Engine space cover
22	Circulating water coupling
23	Hydraulic oil tank
24	First aid box and warning triangle (optional)
25	Auxiliary tools
26	7-pin socket for spreader control cable (optional)
27	Rear fog light (optional)
28	Reversing light (optional)

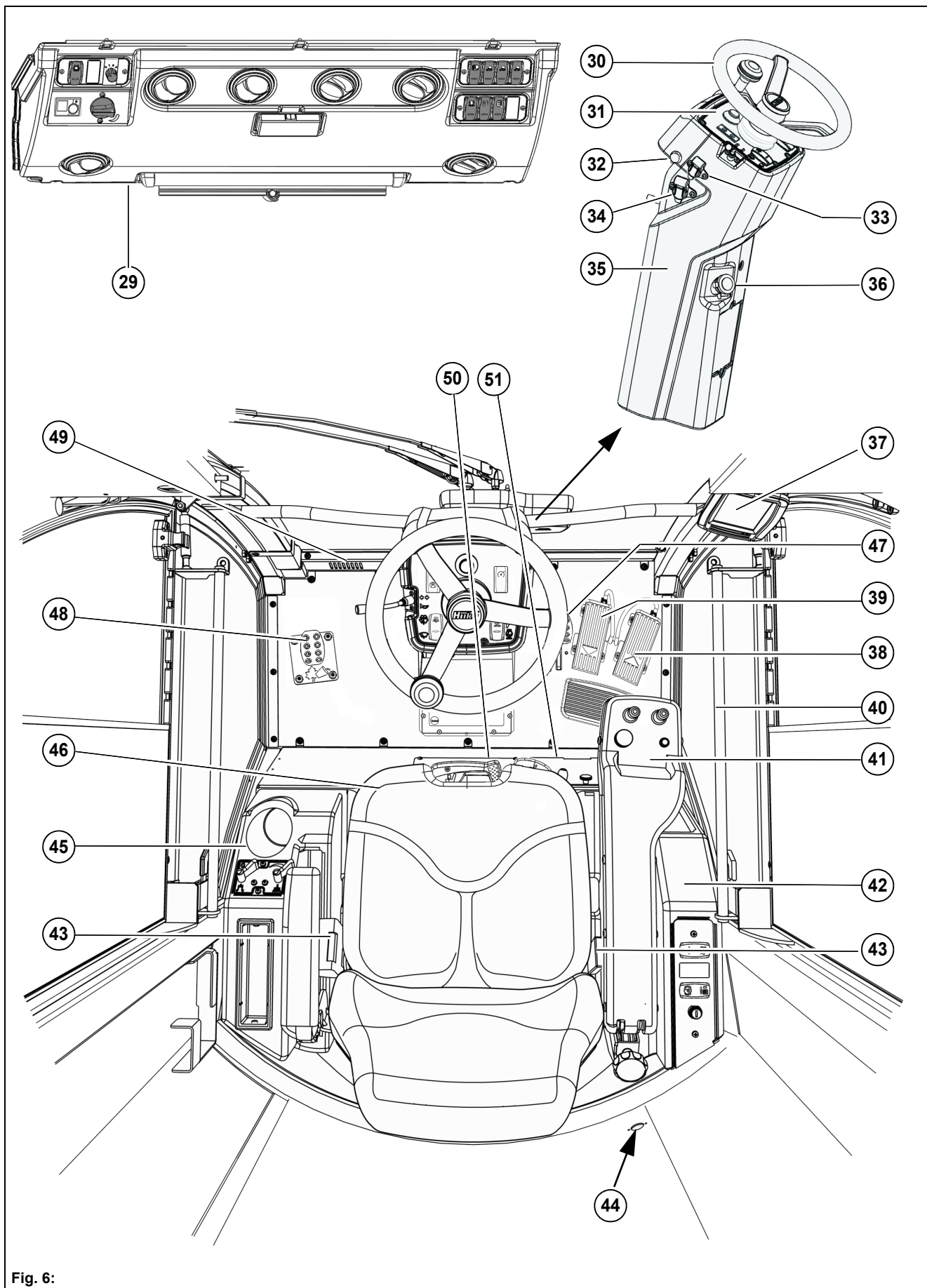


Fig. 6:

2.1.3 Driver's cab

Item	Designation
29	Inside roof control panel
30	Steering wheel
31	Steering column control panel
32	USB charging socket
33	Socket for spreader control cable on the steering column
34	3-pin socket
35	Steering column
36	Windscreen washer unit filling opening
37	Multifunctional display
38	Forwards accelerator pedal
39	Reverse accelerator pedal
40	Door handle
41	Right arm rest control panel
42	Right-hand control panel
43	Seat belt
44	Socket for spreader control cable on the driver's cab outside
45	Left-hand control panel
46	Driver's seat
47	Brake pedal
48	Coarse material flap pedal
49	Foot space air vent
50	Electrical system cover
51	Water filter cover

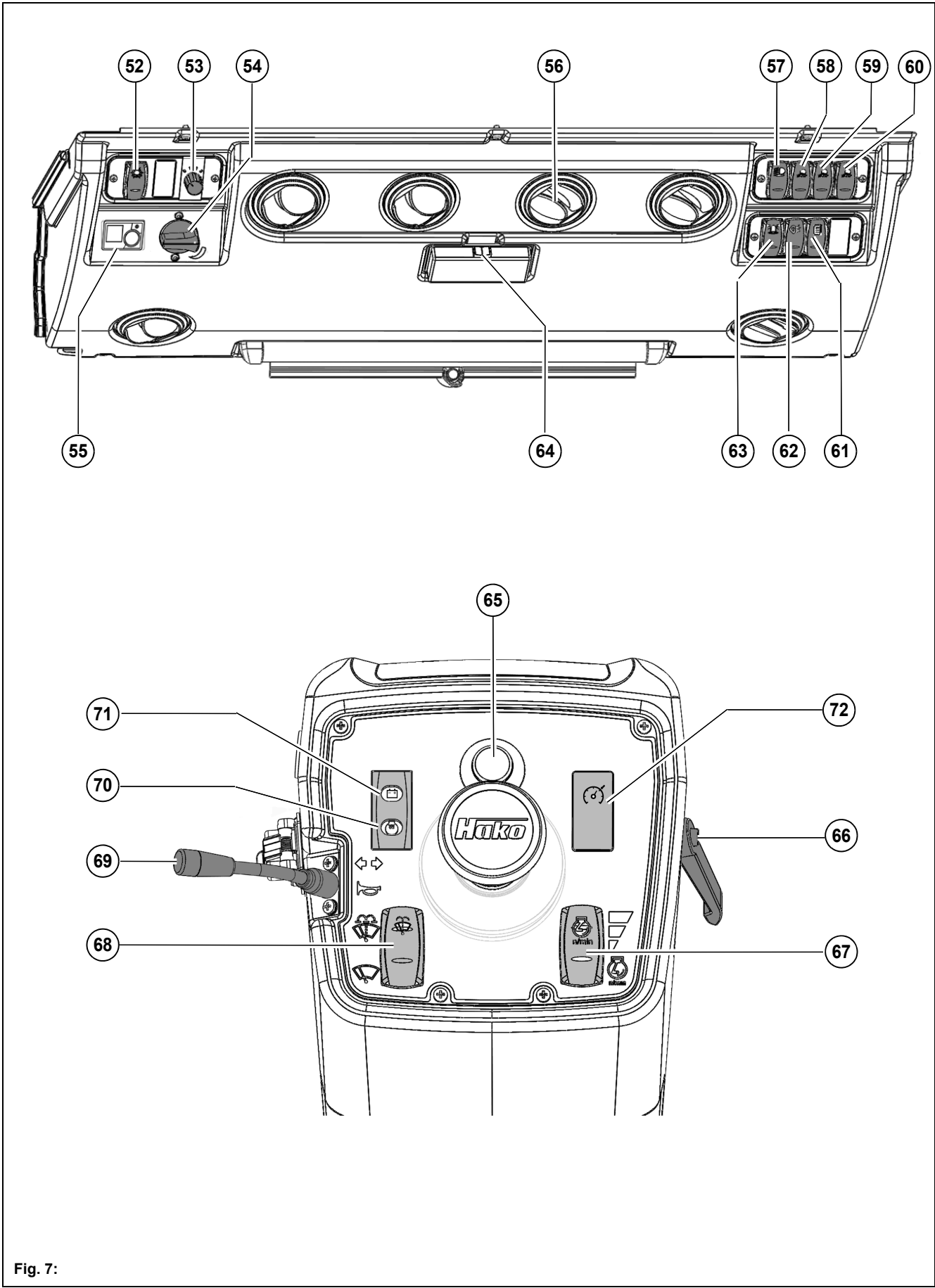


Fig. 7:

Continued – Driver's cab

Item	Designation
Inside roof control panel	
52	Air-conditioner switch
53	Suction fan controller
54	Heating controller
55	Independent vehicle heater timer (optional)
56	Air vent
57	Dipped headlight/side light switch
58	Bottom front cab working light switch Bottom/top front cab working light switch (optional)
59	Rear cab working light switch (optional)
60	Suction mouth working light switch (optional)
61	Mirror heating switch (optional)
62	Rear fog light switch (optional)
63	Rotating beacon switch
64	Inside light switch
Steering column* control panel	
65	Hazard warning system switch
66	Steering column lever
67	Engine fixed speed button
68	Windscreen wiper motor/water pump switch
69	Direction indicator switch/horn button
70	Preheat control light
71	Generator control light
72	Cruise control switch/limiter (optional)

*Comfort steering column (optional), see page 56

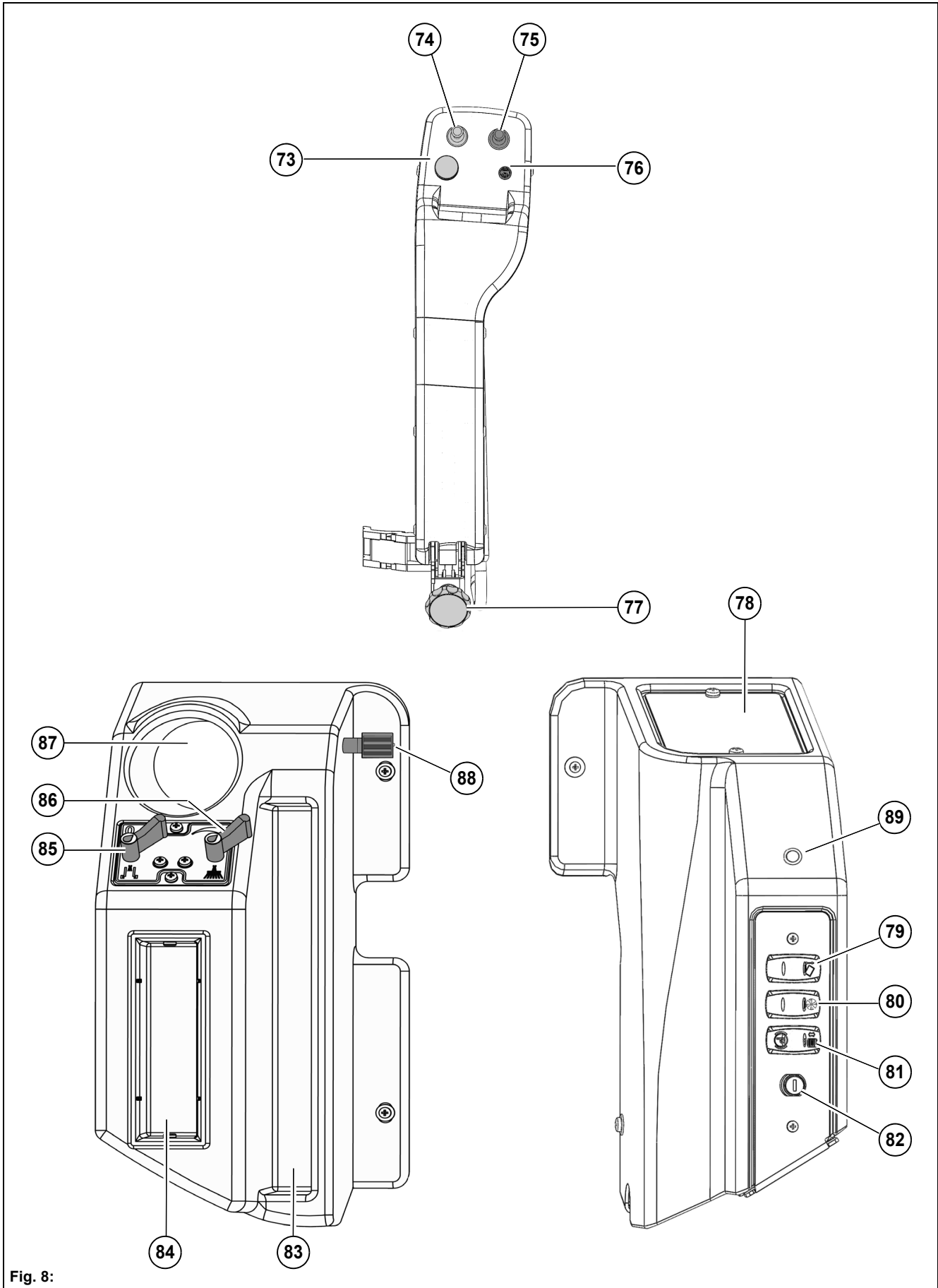


Fig. 8:

Continued – Driver's cab

Item	Designation
Arm rest control panel	
73	Turn-push knob for the multifunctional display
74	Joystick lowering front tool carrier (configuration depending on the attachment)
75	Joystick raising front tool carrier (configuration depending on the attachment)
76	Hako button
77	Armrest star-shaped handle
Right-hand control panel	
78	Fuse box
79	Raise/lower dirt hopper switch
80	Cooling system reversing fan switch
81	Electrical parking brake
82	Ignition switch
83	Operating manual shelf
Left-hand control panel	
84	Radio installation space
85	Fresh water amount at the suction mouth lever
86	Sweeper fresh water amount lever
87	Drink holder
88	Front tool carrier lowering valve
89	Fleet-Recorder with iButton Reader (optional)

2.2 Multifunctional display

2.2.1 Start screen



Fig. 9:

Functions and indicators of the vehicle are set and displayed with the multifunctional display **Fig. 9-37**.

After the vehicle is switched on, the operating system and data are loaded and the start screen appears on the display. The version number of the control unit is shown on the start screen at the bottom left and the version number of the display software at the bottom right.

2.2.2 Menu guidance

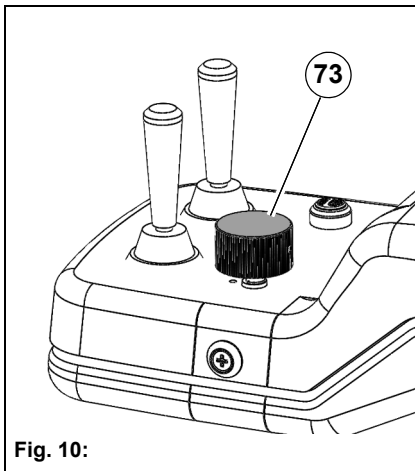


Fig. 10:

The menu is operated with the turn-push knob **Fig. 10-73**. The turn-push knob is located in the right armrest of the driver's seat.

Menus and submenus are selected in the multifunctional display and the individual menu item values are set or changed with the turn-push knob.

The basic principles in this case are:

- Turn to select a menu item.
- Push to activate a menu item.
- Turn to change a value.

If no setting is made for around two seconds, the cursor jumps back again.

2.2.3 Menu structure

The menu structure of the multifunctional display is divided into several levels.

- The information and warning symbols and the most important operating data are shown in the normal view.
- Operating settings such as the output of the hydraulic oil circuit I/II or the relief of the front tool carrier (optional) are made in the working menu (A menu).
- The pre-settings for the normal view are made in the operating menu (B menu).
- Basic settings such as date, time, units, etc. are made in the configuration menu (C menu).

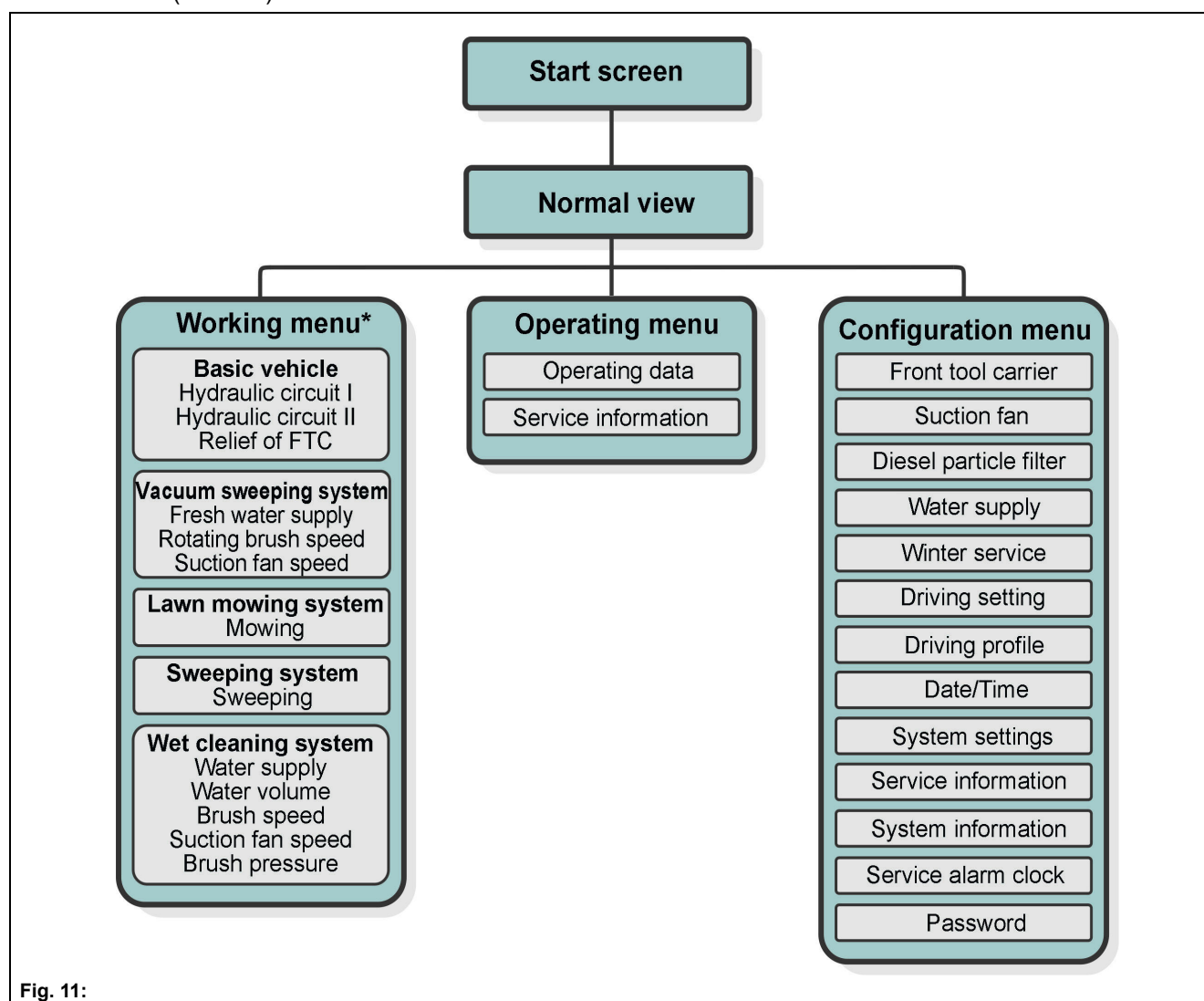


Fig. 11:

*) according to the option or attachment

2.2.4 Normal view

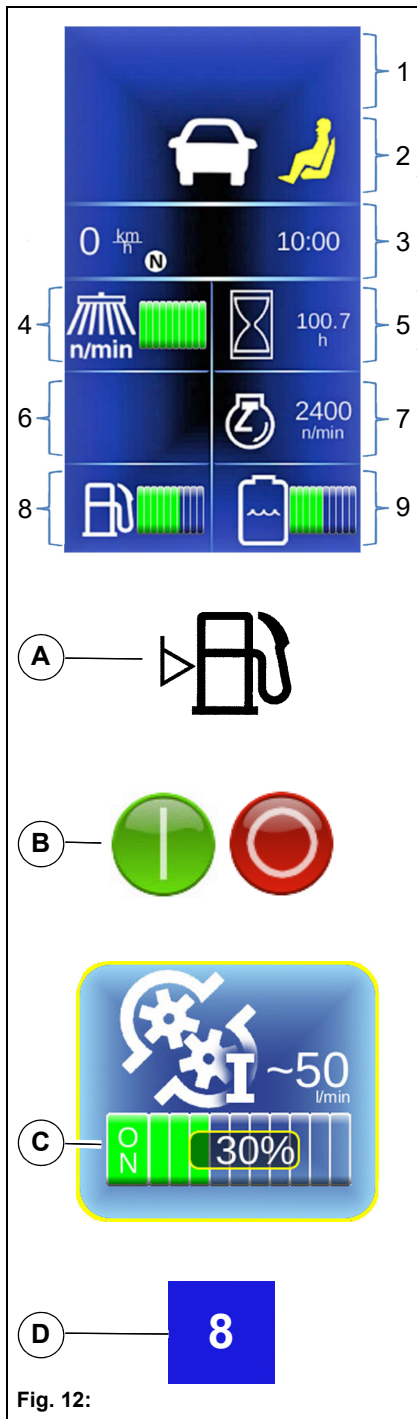


Fig. 12:

General structure

The normal view appears automatically after the start screen. The current vehicle data are displayed in the normal view. The user can determine partially in the operating menu the vehicle data that are displayed. The other part of the vehicle data is determined by the vehicle condition (e.g. current engine speed).

The normal view **Fig. 12** is structured as follows:

- 1 Warning and information symbols
- 2 Warning and information symbols and detected attachment
- 3 Speed/pedal indicator, blinkers and time
- 4 Attachment parameters
- 5 Operating times
- 6 Service information
- 7 Current engine speed/fixed speed mode
- 8 Drive data
- 9 Hydraulic data

Vehicle data

The vehicle data are displayed as symbols, switches, bar charts or numbers.

A Symbols

- Example: Fuel supply low
Special feature:
Warning symbols are displayed red or yellow shining or flashing.
Information symbols are displayed green or white.

B On and Off switches

C Bar chart

- Example: Hydraulic circuit I
The bar chart can be set from 0 to 100%.
Special feature: the range can be restricted for certain parameters.
For example, the suction fan has a setting range of 30% to 100%.

D Numbers

- Example: Suction fan run-on (8 seconds)

2.2.5 Working menu (A menu)

Adjustable indications are displayed on entry into the working menu **Fig. 13**. All indications are displayed one after the other by pushing the turn-push knob **Fig. 13-73**. The operator can change the values in the current display by turning the turn-push knob.

The following displays are possible according to the attachment:

1. Basic vehicle:
 - Hydraulic circuit I (front attachment), see page 78
 - Hydraulic circuit II (rear attachment), see page 80
 - Relief of front tool carrier (optional), see page 75
 - Water pump ON/OFF, see page 59
2. Vacuum sweeping system (2-brush system and 2-brush system (comfort)):
 - Water pump ON/OFF/Volume, see page 153
 - Rotating brush ON/OFF/Speed, see page 152
 - Suction fan ON/OFF/Speed, see page 153
3. Vacuum sweeping system (3-brush system):
 - Water pump ON/OFF/Volume, see page 153
 - Pulled rotating brushes ON/OFF/Speed, see page 152
 - Pulled rotating brushes brush pressure, see page 152
 - 3rd rotating brush ON/OFF/Speed, see page 152
 - 3rd rotating brush brush pressure, see page 152
 - Suction fan ON/OFF/Speed, see page 153
4. Lawn mowing system:
 - Mower ON/OFF, see page 174
 - Suction fan ON/OFF/Speed, see page 176
 - Relief of front tool carrier (optional), see page 174
5. Sweeping system (front sweeping roller):
 - Brush ON/OFF/Speed, see page 185
 - Hydraulic circuit II, see page 185
6. Wet cleaning system (CityCleaner):
 - Water pump ON/OFF/Volume, see page 219
 - Relief, see page 220
 - Brushes ON/OFF/Speed, see page 220
 - Suction fan ON/OFF/Speed, see page 220
 - Water type (fresh water/waste water), see page 219
7. Weed brush:
 - Water pump ON/OFF/Volume
 - Rotating brush ON/OFF/Speed
 - Suction fan ON/OFF/Speed
 - Relief of front tool carrier (optional)

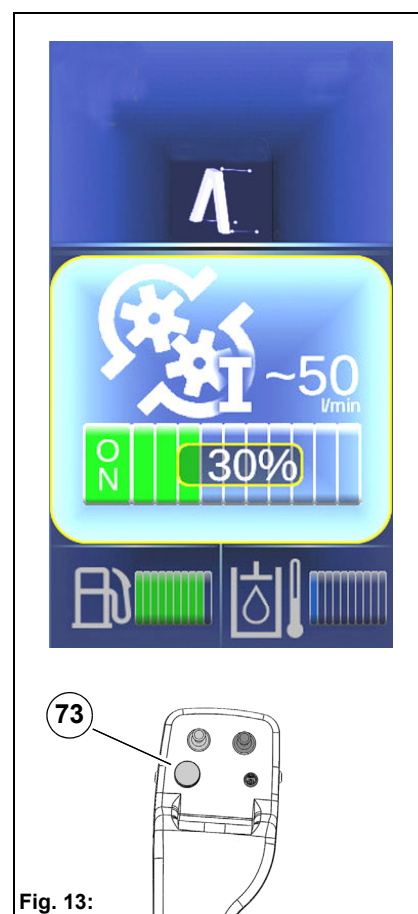


Fig. 13:

Example: Setting the output of hydraulic circuit I

The following example shows how the output of hydraulic circuit I can be changed in the working menu.

1. The normal view (A) is displayed.
2. Turn the turn-push knob **Fig. 14-73**: the last active function (B) is selected. (For example: hydraulic circuit I with maximum 50 litres/minute to 30%).
3. Turn the turn-push knob: the current value is changed. (For example, hydraulic circuit I with 80%).

**Danger**

Risk of injury! Make sure that the attachments are suitable for the set oil volume. An oil volume set too high can lead to injuries due to a defect of the attachment! As a reminder, the setting process is interrupted briefly at 70%.

The change is made immediately in working travel. If the change is made in the transport driving mode, it is activated only on changing to the working driving mode.

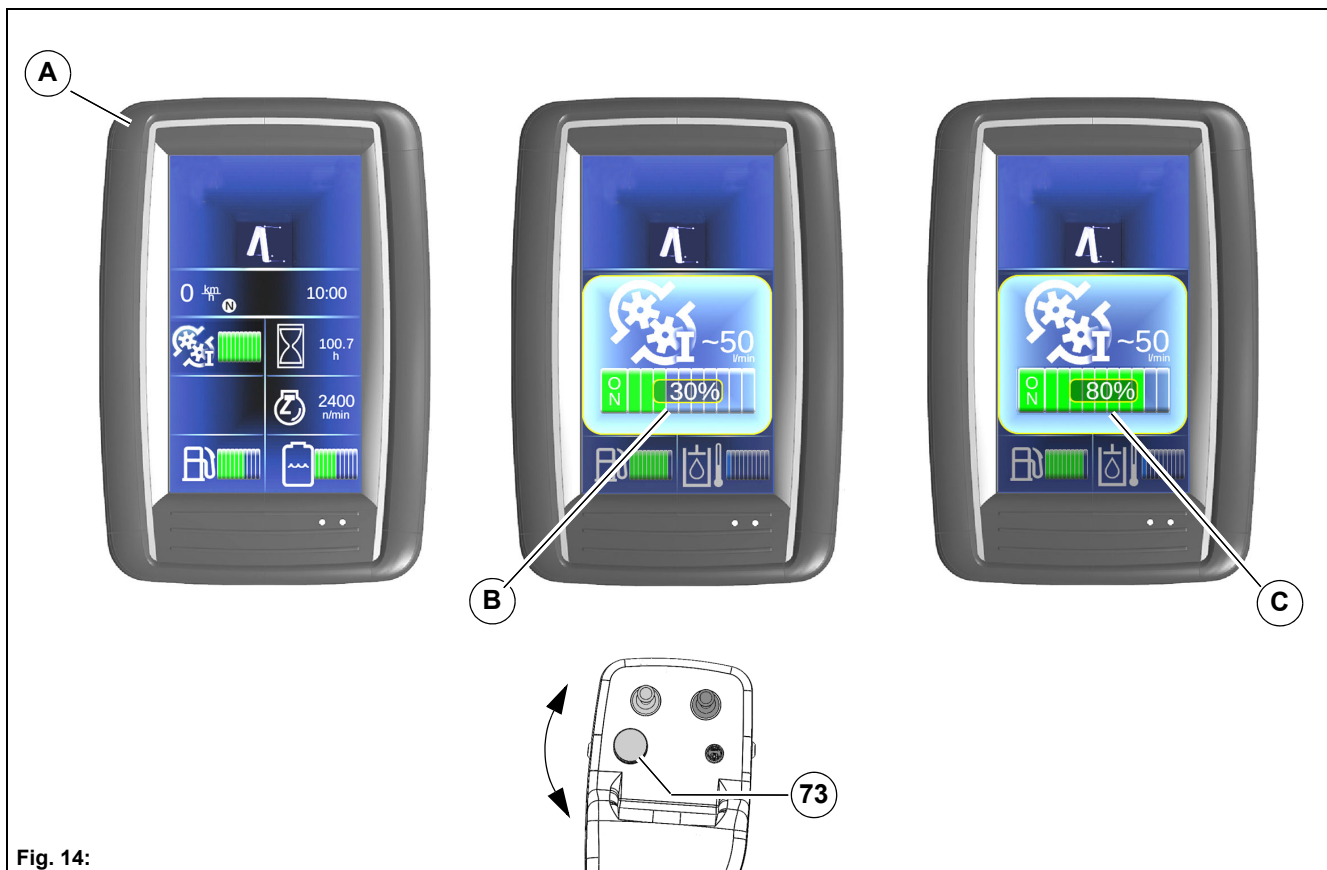


Fig. 14:

2.2.6 Operating menu (B menu)

The displays of the normal view can be combined for the corresponding requirements in the operating menu **Fig. 15**. Different functions can be selected in the fields **(A)**, **(B)** and **(C)**.

The service information is displayed in the field **(D)**.

Operating data

The distances are displayed in kilometres (km) or miles (mi) depending on the system setting in the configuration menu. System setting, see page 41.

The displayed counter is reset by pushing the turn-push knob **Fig. 15-73** for a long time.

Field A:

- 1 Operating hours total
- 2 Operating hours resettable
- 3 Work hours total
- 4 Work hours resettable
- 5 Sweeping kilometres total
- 6 Sweeping kilometres resettable
- 7 Distance total
- 8 Distance resettable

Field B:


- 9 Fuel supply
- 10 Cooling water temperature

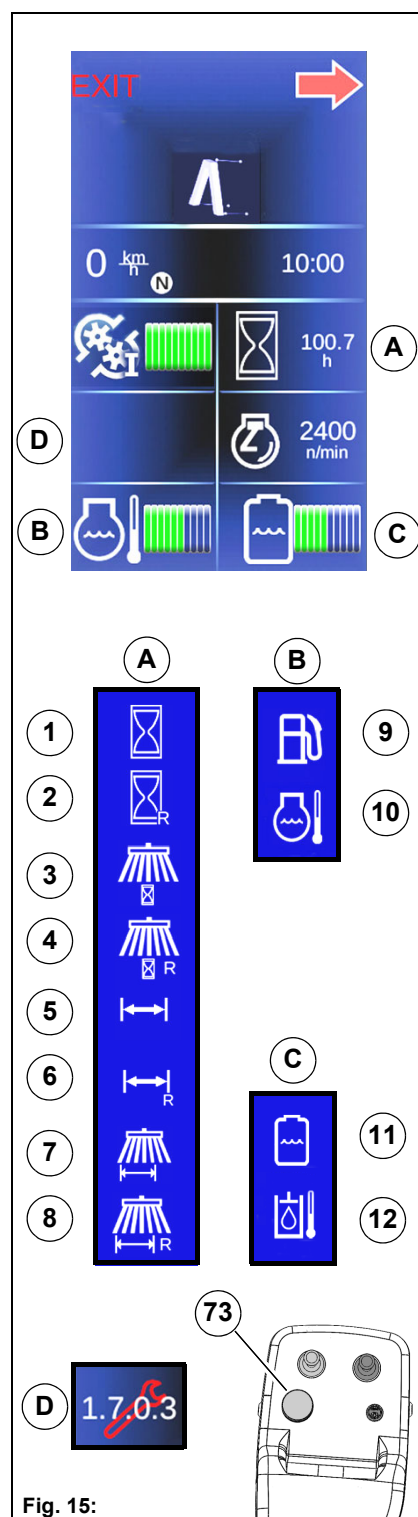
Field C:

- 11 Fresh water supply
- 12 Hydraulic temperature

Service information

If a service information has occurred since the ignition was switched on, a 4-digit code is displayed in **field D**. If the code is currently active, a red flashing wrench appears in addition.

	<p>Note</p> <p>The displayed service information can be hidden after error rectification by pushing the turn-push knob for a long time.</p>
---	--



Example: Selecting the fuel gauge

The following example explains how to change the operating data display from cooling water temperature to fuel gauge in the operating menu.

1. In the normal view **(A)**, push the turn-push knob **Fig. 16-73** for at least two seconds. The operating menu is activated. The cursor stands on the EXIT symbol **(B)**.
2. Turn the turn-push knob and move to the field **(C)**.
3. Push the turn-push knob. Field **(C)** is activated.
4. Turn the turn-push knob and select the fuel gauge **(D)**.
5. Push the turn-push knob. The new function is taken over.
6. Turn the turn-push knob and exit the operating menu via the EXIT symbol **(E)**.

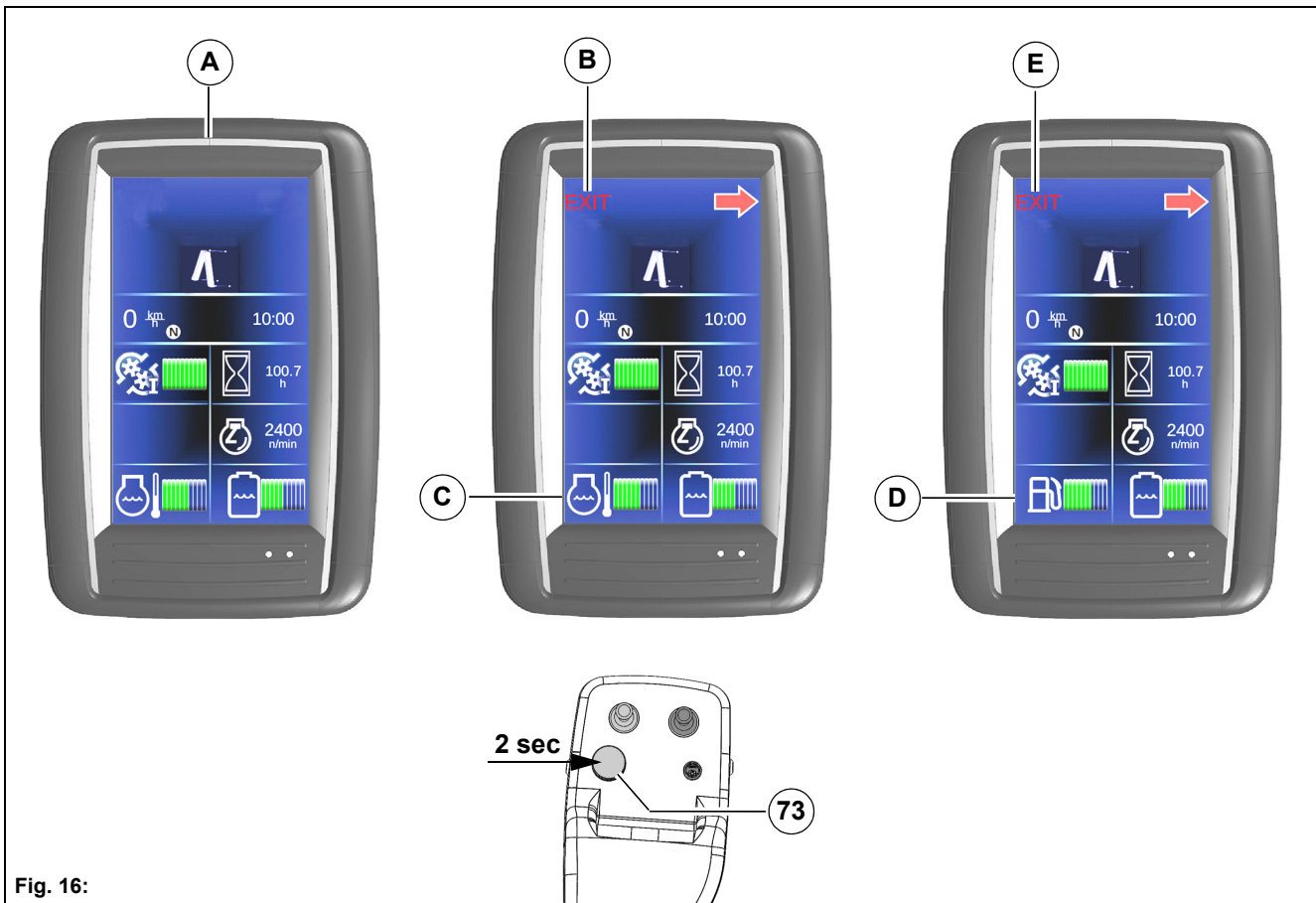


Fig. 16:

2.2.7 Configuration menu (C menu)

The configuration menu **Fig. 17** consists of a chapter overview which is divided into two pages. If the green arrow symbol is selected with the turn-push knob, you access the second page of the chapter overview. After selecting a symbol with the turn-push knob, it is branched into the menu where you can make settings.

- Exit the configuration menu via the EXIT symbol (**A**)
- Next/Previous page via the arrow symbol (**B**)

Requirements: the accelerator pedal must be in the neutral position.

The following menus are available:

Menu	Function
1	Front tool carrier
2	Suction fan
3	Diesel particle filter
4	Water supply
5	Winter service
6	Driving settings
7	Driving profile
8	Date/Time
9	System settings
10	Service information
11	Vehicle information
12	Service alarm clock
13	Password

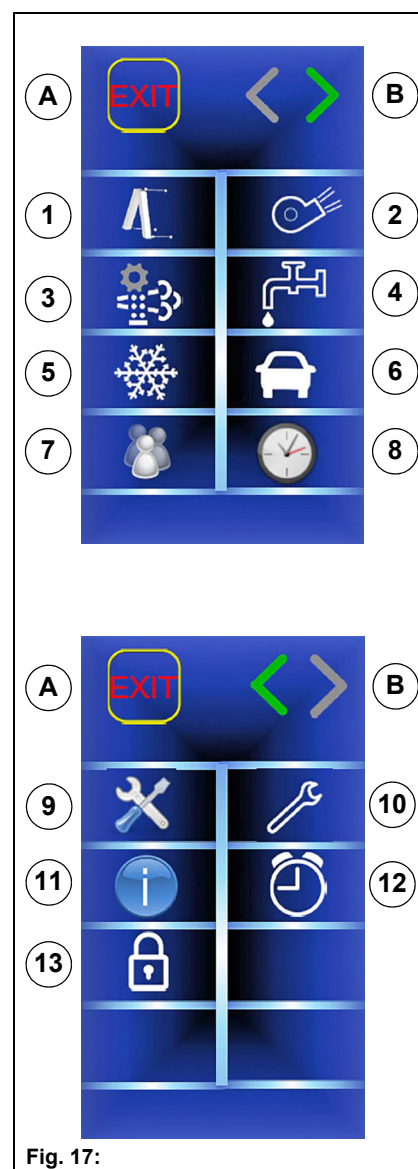
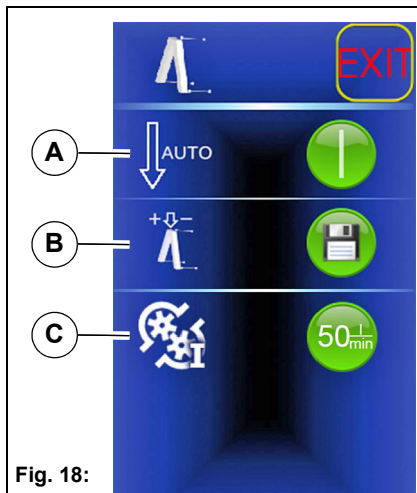
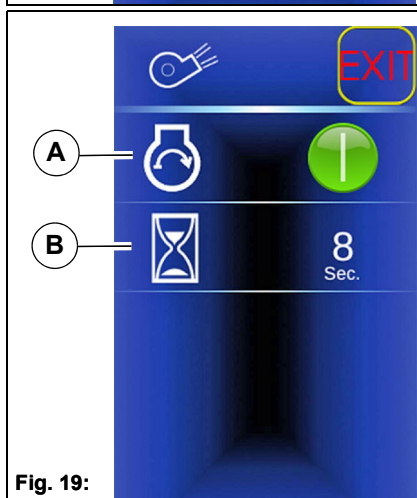


Fig. 17:



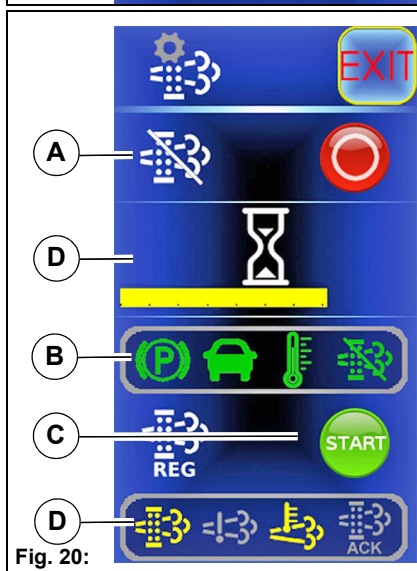
Front tool carrier menu Fig. 18

- A** Lower the front tool carrier with Hako button
 - 0 ... Automatic OFF
 - 1 ... Automatic ON
- B** Relief of front tool carrier
 - 0 ... Last value
 - 1 ... Always floating position
- C** Release 70 l/min (oil volume of front tool carrier)
 - 50 ... Hydraulic circuit I limited to 50 l/min
 - 70 ... Hydraulic circuit I released for 70 l/min



Suction fan menu Fig. 19

- A** Suction fan after ignition ON
 - 0 ... OFF
 - 1 ... ON
 - 2 ... Last value in ignition OFF
- B** Suction fan run-on
 - 0 to 15 seconds (standard: 8 seconds)



Diesel particulate filter menu Fig. 20

- A** Diesel particulate filter regeneration lock
 - 0 ... OFF
 - 1 ... ON
- B** Conditions that must be fulfilled for manual regeneration
- C** START symbol for starting manual regeneration
- D** Status display during regeneration

Further description, see page 91

Water supply menu Fig. 21**A** Water pump activation after ignition ON

- 0 ... Last value
- 1 ... Always ON

B Water pump function for uncoded attachment

- 0 ... Not available
- 1 ... Available

C Water supply for the 3-brush system (optional)

- 0 ... OFF
- 1 ... ON

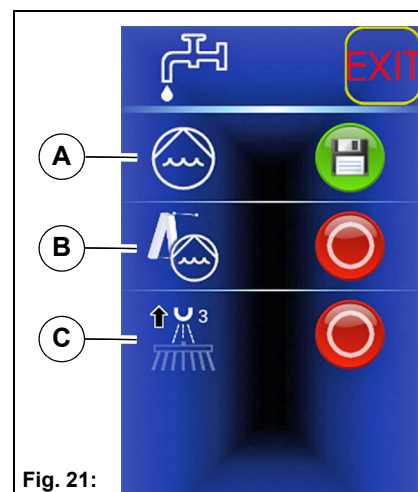


Fig. 21:

Winter service menu Fig. 22**Danger**

Risk of accident due to unintended lowering of the attachment! Activate winter operation in the configuration menu only in connection with an uncoded snow blade. The front lift is then not limited downwards. Winter operation must be deactivated immediately after use.

A Winter operation ON/OFF

- 0 ... OFF (standard)
- 1 ... ON

B Spreader run-on

- 0 to 4 seconds (standard: 0 seconds)

C Spreader fast emptying ON/OFF

- 0 ... OFF
- 1 ... ON

D Spreader depending on the pedal setting

- 0 ... OFF
- 1 ... ON (standard)

Further description, see page 198

Driving settings menu Fig. 23**A** Signal tone on flashing

- 0 ... OFF
- 1 ... ON (standard)

B Signal tone on reversing

- 0 ... OFF
- 1 ... ON (standard)

C Tyre type

- see selection list

D Warning tone when driving with raised dirt hopper (is automatically reset to "ON" when the dirt hopper is moved)

- 0 ... OFF
- 1 ... ON (standard)

E Speed reduction in working travel

Limit value in %

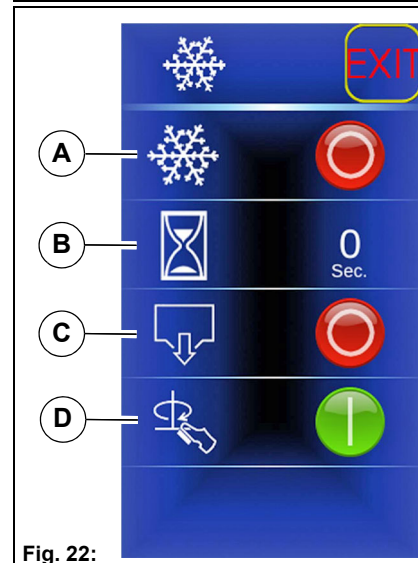


Fig. 22:

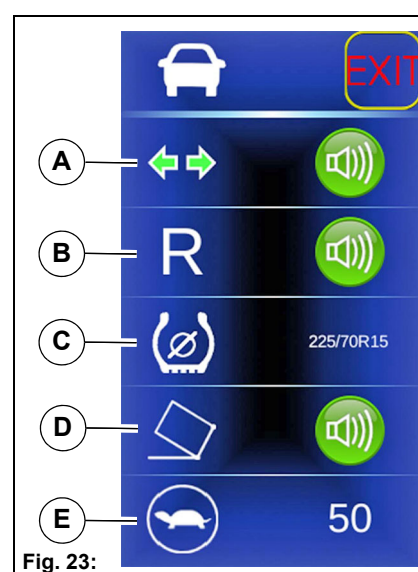


Fig. 23:

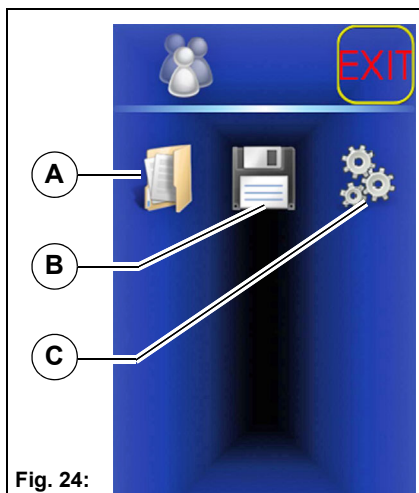


Fig. 24:

Driving profiles menu Fig. 24

- A Load settings
- B Save settings
- C Load standard values

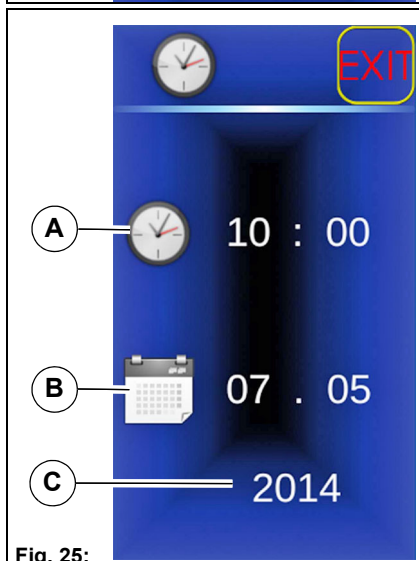


Fig. 25:

Time/date menu Fig. 25

- A Time in (hours : minutes)
- B Date in (day : month)
- C Year

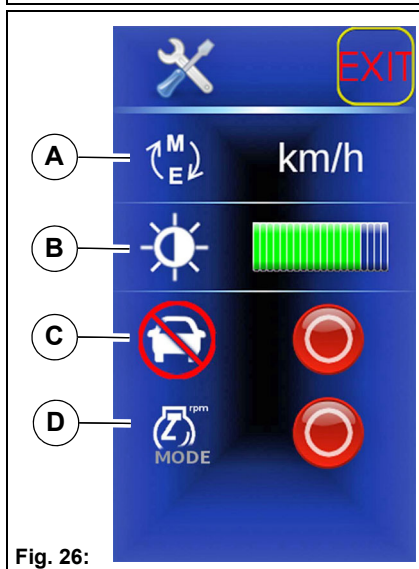


Fig. 26:

System settings menu Fig. 26

- A km/mi changeover
 - km/h (standard)
 - mi/h
- B Display brightness
 - Standard: 80% (In automatic mode, the display brightness is controlled by a brightness sensor)
- C Overwriting the fleet release
- D Mode for fixed speed
 - 0 = normal mode
 - ECO = only minimum fixed speed available (boost for the suction fan can only be switched on briefly for 1 minute)
 - Max Off = maximum fixed speed permanently locked

Service information menu Fig. 27**A** If time stamp has been selected:

- The last ten items of service information are displayed with time stamp and error number
- If no time stamp is available, the error occurred immediately at ignition ON or the display was switched off or not ready

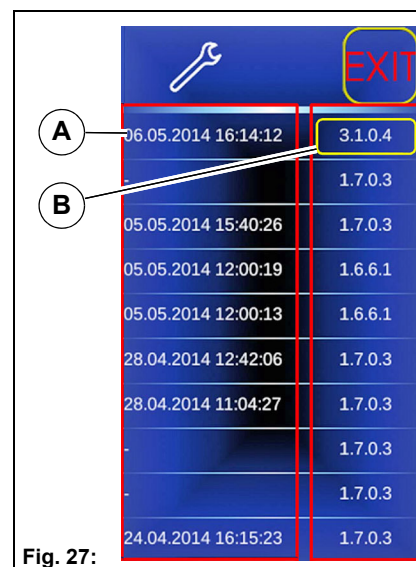
B If the error code is selected and confirmed, the detailed error description sub-menu opens

Fig. 27:

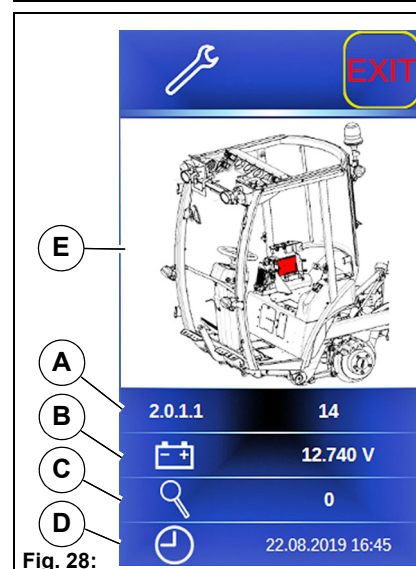
Detailed service information sub-menu Fig. 28**A** Error code and internal error number**B** Supply voltage at time of error in mV**C** Additional parameters (meaning depending on error)**D** Date when the error occurred**E** Components involved in the error light up red in the graphic

Fig. 28:

Vehicle information menu Fig. 29**A** Vehicle type**B** Recognised attachment

- Example: Sweeping system with two rotating brushes

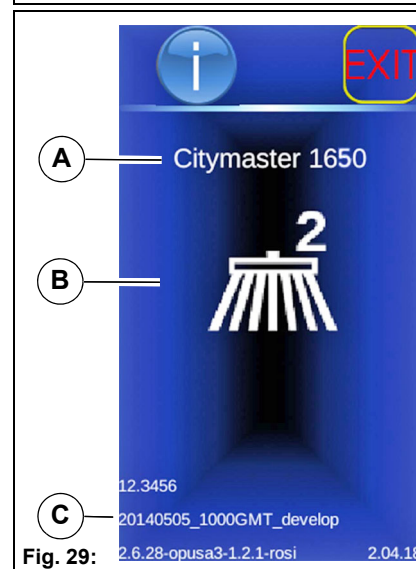
C Software statuses

Fig. 29:

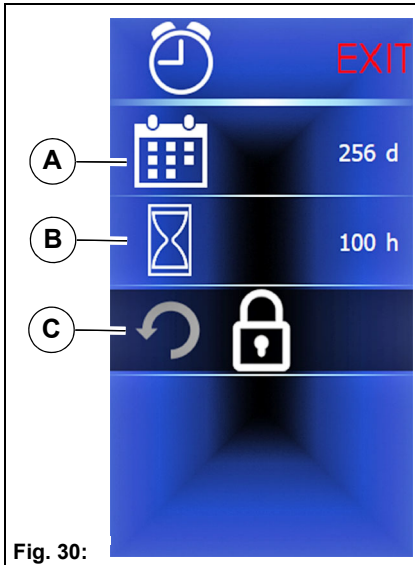


Fig. 30:

Service alarm clock menu Fig. 30

- A** Remaining time of the annual service alarm clock in days
- B** Remaining time of the operating hours alarm clock in hours
- C** Resetting the service alarm clock

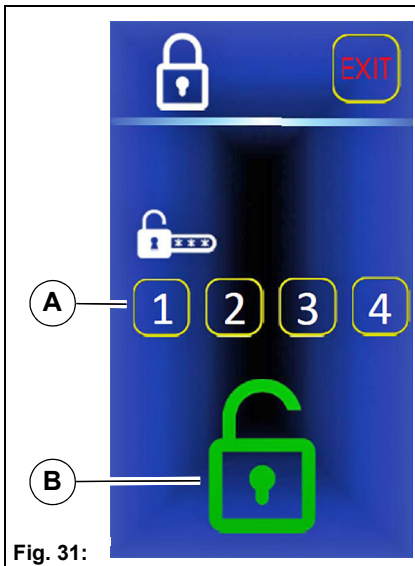


Fig. 31:

Password menu Fig. 31

Changing special entries in the configuration menu can be locked and requires access authorisation.
Tyre type example:



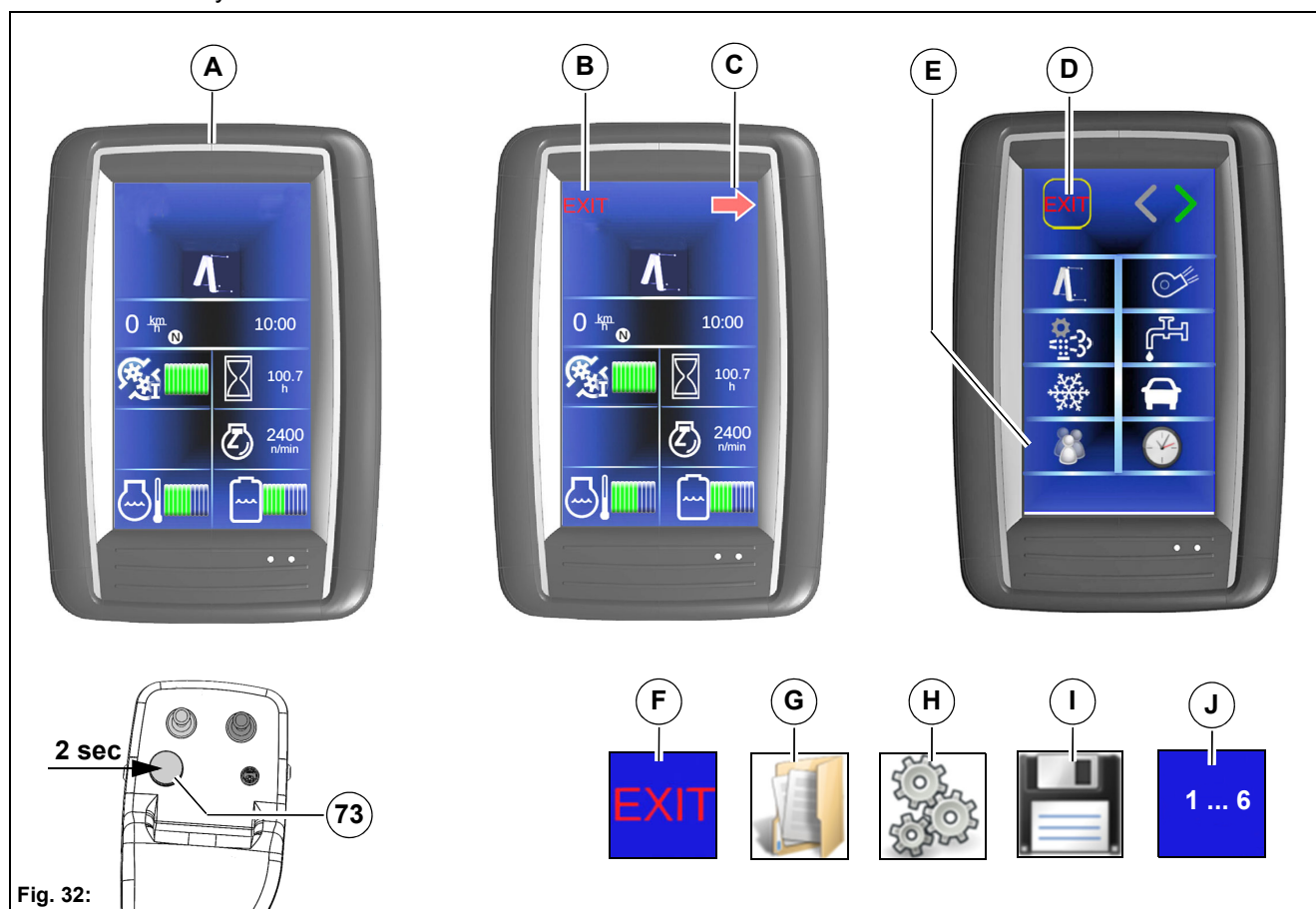
- A** Entry of the password to unlock protected entries.
- B** The green lock symbolises a correct password. The lock is hidden when entering the password.

Example: Driving profile setting

The following example explains how to make a setting in the driving and sweeping program.















1. In the normal view **(A)**, push the turn-push knob **Fig. 32-73** for at least two seconds. The operating menu is activated. The cursor stands on the EXIT symbol **(B)**.
2. In the operating menu turn the turn-push knob and move to the arrow symbol **(C)**.
3. In the operating menu push the turn-push knob. The configuration menu is activated. The cursor stands on the EXIT symbol **(D)**.
4. In the configuration menu, turn the turn-push knob and move to the driving profile menu **(E)**.
5. In the configuration menu push the turn-push knob. The driving profile menu is selected. The cursor stands on the EXIT symbol **(F)**.
6. Turn the turn-push knob in the driving profile menu. There are the following possibilities:
 - Loading a sweeping program with the symbol **(G)**
 - Resetting to defaults with the symbol **(H)**
 - Saving the current parameters with the symbol **(I)**
 - Selecting the storage place for loading or saving: 1 to 6 **(J)**
















Select the EXIT symbol to exit the menu.







2.2.8 Warning and information symbols














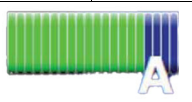


Warning symbols

Colour	Symbol	Function	Remedy
Red		Charge control	The control light of the generator lights up when the ignition is switched on, but goes out as soon as the engine is started. If the control light goes on when the engine is running, this signals: defect on the V-belt of the generator or defect in the charge circuit of the generator. The battery is no longer being charged! Immediately stop the vehicle safely and if necessary notify an authorised workshop.
Red		Engine oil pressure low	If the warning symbol appears, there is a risk of engine damage. Immediately stop the vehicle safely and check the engine oil level.
Red		Cooling water temperature too high	If the warning symbol appears, there is a risk of engine damage. Immediately stop the vehicle safely and check the engine oil level.
Yellow		Cooling water level low	Switch the engine off and check the cooling water level.
Red		Hydraulic oil temperature too high	If the warning symbol appears, there is a risk of operating failure of the hydraulic system. The hydraulic oil temperature is too high! Stop the vehicle safely and switch off all hydraulic units.
Yellow		Hydraulic oil level low	Switch the engine off and check the hydraulic oil level.
Red		Parking brake on	The warning symbol appears if the parking brake is on.
Red		Hopper overload (optional)	Empty the dirt hopper immediately if the warning symbol appears.
Red		Work mode blocked	Enable work mode using Fleet-Recorder (optional).
Red		Transport mode blocked	Enable transport mode using Fleet-Recorder (optional).
Yellow		Diesel particulate filter error (NCD lamp)	
Red		Service now	Service (maintenance) is due now. The operating hours for the maintenance due have been exceeded.
Yellow		Service reminder	The yellow wrench appears 10% before the set maintenance interval expires. Example: With 500 operating hours, the yellow wrench is used to indicate that maintenance is due 50 operating hours before actual expiry.
Yellow		Diesel particulate filter regeneration required	




Yellow		Diesel particulate filter regeneration active	Warning of hot exhaust gases.
Yellow		Diesel particulate filter locked by user	
Yellow		Engine fault	If the warning symbol appears with the engine running, there is a risk of engine damage. Immediately stop the vehicle safely and notify an authorised workshop.
Yellow		Low fuel supply	If the warning symbol flashes, then refuel without delay. There is a risk of engine damage if the fuel system is run completely empty! Inform an authorised workshop!
Yellow		Preheat	There is an engine fault if the warning symbol flashes. There is a risk of engine damage. Immediately stop the vehicle safely and notify an authorised workshop.
Yellow		Low hydraulic supply	Increase work speed.
Yellow		Air filter clogging warning	Clean the air filter.
Yellow		Loss of traction	Snow chains / different subsurface / different tyres.
Yellow		Suction mouth lowered	Raise suction mouth using joystick.
Yellow		Brake request	Operate brake.
Yellow		EMERGENCY stop active	Stop vehicle safely and notify an authorised workshop.
Yellow		Limp-home mode active	Stop vehicle safely and notify an authorised workshop.
Yellow		Low fresh water supply	Filling fresh water.
Yellow		Hopper raised	As long as the dirt hopper is not in its lower end position, the warning symbol appears.
Yellow		Driver not on driver's seat	The warning symbol appears if the driver leaves the driver's seat during operation.










Information symbols, general

Colour	Symbol	Function
Yellow		Cruise control active
Green		Vehicle blinker
Green		Trailer blinker
Green		Hazard warning system on













Green		Side and rear lights
White		Accelerator pedal in neutral position
White		Speed level 1 lights up constantly or flashes
White		Speed level 2 lights up constantly or flashes
White		Speed level D flashes: implausible accelerator pedal signals
White		Speed limiter active
White		Front switching output ON
White		Reversing fan active
White		Hydraulic oil temperature
White		Cooling water temperature
White		Fuel supply
White		Fresh water supply
White	1.1.1.1	Fault code
White		Current engine speed
		Automatic mode – brightness display
		ECO – minimum fixed speed available (see System settings menu Fig. 26)
		MaxOff – maximum fixed speed permanently locked (see System settings menu Fig. 26)




Information symbols for attachments

Colour	Symbol	Function
White		Transport mode
White		Work mode with front mower
White		Work mode with CityCleaner









White		Work mode with 3-brush system
White		Work mode with 2-brush system
White		Work mode with front sweeping machine
White		Work mode with front tool carrier or unknown attachment
White		Front tool carrier floating position activated
White		Front tool carrier in upper end position
White		Winter service activated
White		Weed brush
White		Sweeping unit 2-brush system (comfort)

Information symbols for attachment parameters

Colour	Symbol	Function
White		Brush speed
White		Brush speed 3rd brush
White		Relief of pulled brushes
White		Relief of 3rd brush
White		Rotation speed
White		Mower speed
White		Hydraulic circuit I
White		Hydraulic circuit II
White		Relief of front tool carrier
White		Brush speed
White		Water type / fresh water
White		Relief of brushes

White		Rear spreader
White		Suction fan
White		Relief of mower

Information symbols for operating hours and kilometre counters

Colour	Symbol	Function
White		Operating hours total
White		Operating hours resettable
White		Total sweeping hours
White		Sweeping hours, resettable
White		Total kilometres
White		Kilometres, resettable
White		Sweeping kilometres total
White		Sweeping kilometres resettable

2.3 Controls in the driver's cab

2.3.1 Steering column control panel

Adjusting the steering column



Danger

Risk of accident! If the steering column **Fig. 39-35** is unlocked while driving, it can come unexpectedly out of adjustment. You can then lose control over the vehicle.

The steering column **Fig. 33-35** can be adjusted to the corresponding driver position with a lever.

- Turn the lever **Fig. 33-A** counter-clockwise until the steering column is unlocked.
- Set the required steering column adjustment.
- Turn the lever clockwise until the steering column is locked.

Check that the steering column is locked. To do this move the steering wheel **Fig. 33-30** in the longitudinal direction.

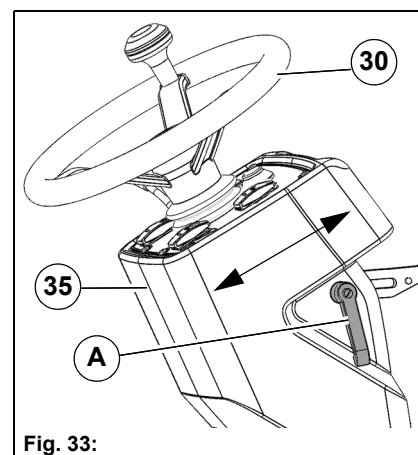


Fig. 33:

Setting the fixed engine speed

The fixed engine speed and thus the system output of the vehicle in the work mode is set with the button **Fig. 34-67**.

Stage	rpm	Hydraulic circuit I Litres/minute	Hydraulic circuit II Litres/minute
1 - ECO	1600	50	20
2 - Standard	2000	50/70	27
3 - Maximum	2400	50/70	32

The overview illustrates that sufficient power is available already in the ECO mode for many applications.

The full hydraulic output is reached as from the Standard speed. Additional energy is available in the driving mode as well as in hydraulic circuit II at Maximum. Set the speed according to the requirements. Operation primarily in the ECO mode lowers consumption and noise. See pages 78 and 80 for information about setting the hydraulic circuits.

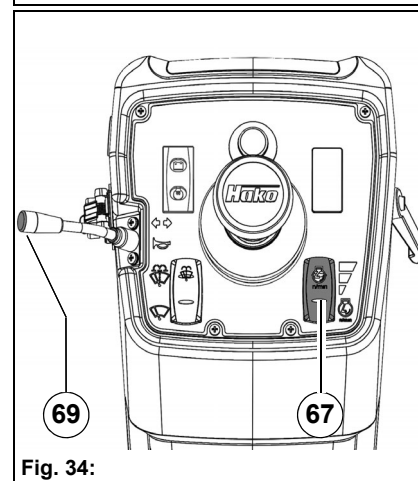


Fig. 34:

Horn

The horn is switched on and off with the button **Fig. 34-69**.

- Push the button: horn ON
- Release the button: horn OFF

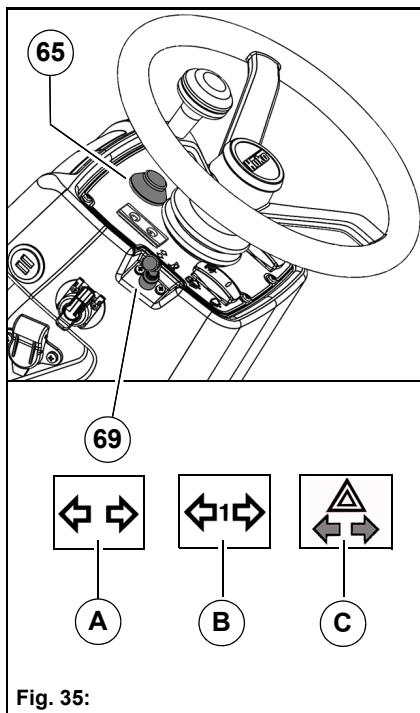


Fig. 35:

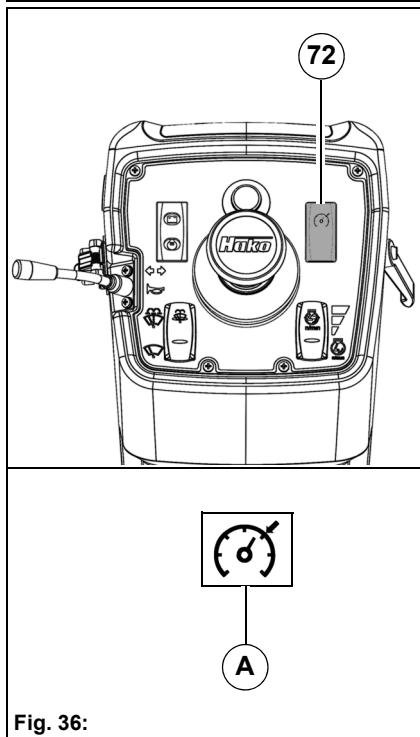


Fig. 36:

Switching the hazard warning system on and off

The hazard warning system is switched on and off with the switch **Fig. 35-65**. The direction indicators **Fig. 4-3** and **Fig. 5-18** flash. The hazard warning system also functions in position P of the ignition switch.

- Switch in stage I: hazard warning system OFF
- Switch in stage II: hazard warning system ON

The lamps are monitored. Fast flashing signals a defective lamp.

The warning light information symbol **Fig. 35-C** appears in the multifunctional display.

Direction indicators

The direction indicators **Fig. 4-3** and **Fig. 5-18** are switched on and off with the switch **Fig. 35-69**. The direction indicators also function in position P of the ignition switch.

- Switch in stage I: left direction indicator switch ON
- Switch in stage II: direction indicator switch OFF
- Switch in stage III: right direction indicator switch ON

The lamps are monitored. Fast flashing signals a defective lamp.


In the multifunctional display, the flasher information symbol **Fig. 35-A** appears, or in trailer operation the trailer operation flasher information symbol **Fig. 35-B**.

Cruise control and speed limiter (optional)

The cruise control and speed limiter is available only in work mode. The current speed is set in the first position of the switch **Fig. 36-72**. In this case the road speed is controlled so that it is not lower or higher than the speed set with the cruise control. The cruise control symbol **Fig. 36-A** appears in the multifunctional display. The cruise control is switched off again in the neutral position of the switch.

If the driver presses the accelerator pedal, the road speed is increased without the cruise control being deactivated. For reasons of safety, the cruise control switches off immediately when the brake pedal is operated.

The speed limiter determines the maximum road speed with the accelerator pedal pushed down fully. This serves for convenient control of the road speed especially at low working speeds. The speed must be set on the configuration menu. It is activated via the second switch position of the switch **Fig. 36-72**.

	<p>Danger Risk of accident! Use the cruise control and the speed limiter only when the traffic situation allows!</p>
---	---

Generator control light

The control light of the generator **Fig. 37-70** lights up when the ignition is switched on, but goes out as soon as the engine is started. If the control light goes on when the engine is running, this signals: defect on the V-belt of the generator or defect in the charge circuit of the generator. The battery is no longer being charged! Immediately stop the vehicle safely and if necessary notify an authorised workshop.

Preheat control light

The preheat control light **Fig. 37-71** lights up with the ignition switched on. The engine is preheated until the control light goes out.

If the preheat control light flashes, the preheat procedure has been interrupted and must be repeated.

If the preheat telltale flashes when the key in the ignition switch is in position 1, or during slow or fast operation, an error has occurred in the engine control unit.

USB charging socket

The USB charging socket **Fig. 37-32** is used to charge mobile devices such as tablets, smartphones, navigation devices and digital cameras via a USB cable.

Windscreen washer unit

The windscreen washer unit is used for cleaning the windscreen.

The water sprayed onto the windscreen supports the cleaning effect of the windscreen wipers **Fig. 38-6**.

The windscreen washer unit is supplied from the water tank **Fig. 38-36**. Detergents and antifreeze are added to the water as required.



Note

Do not let the windscreen wipers **Fig. 38-6** wipe over dry windscreens for a longer time. Wiper blades wear prematurely due to this and the wiper motor can overheat! Switch the windscreen wipers off with dry windscreens.

The windscreen wiper motor and the water pump are switched on and off with the switch **Fig. 38-68**.

The switch has three positions:

- Position 1: functions of the windscreen washer unit OFF
- Position 2: functions of the windscreen washer unit ON (continuous mode)
- Position 3 (pressed briefly): interval operation ON/OFF

Position 3 (pressed longer): interval operation ON and water pump ON

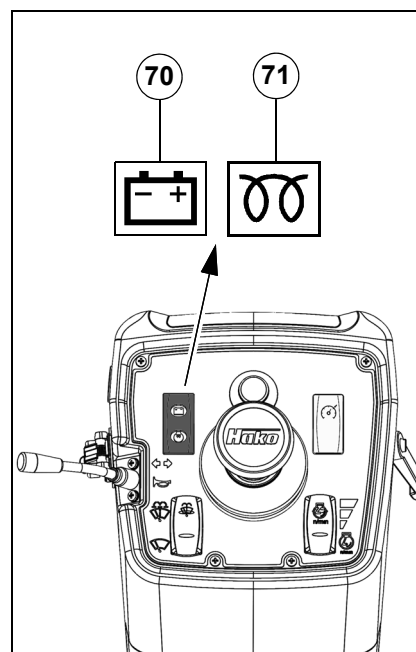


Fig. 37:

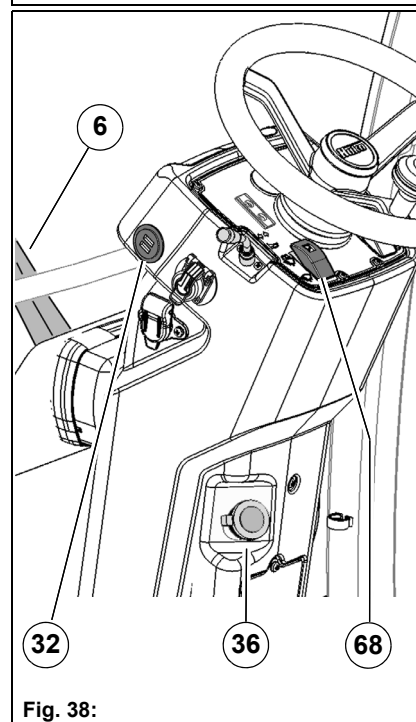


Fig. 38:

2.3.2 Comfort steering column (optional)

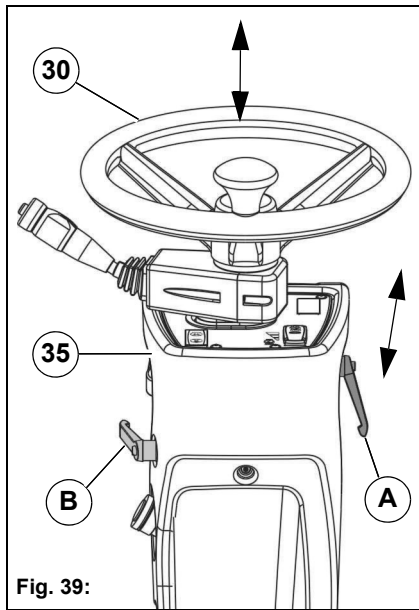


Fig. 39:

Adjusting the steering column



Danger

Risk of accident! If the steering column **Fig. 39-35** is unlocked while driving, it can come unexpectedly out of adjustment. You can then lose control over the vehicle.

The steering column **Fig. 39-35** can be adjusted to the corresponding driver position with a lever.

- Turn the lever **Fig. 39-A** counter-clockwise until the steering column is unlocked.
- Set the required steering column adjustment.
- Turn the lever clockwise until the steering column is locked.

Check that the steering column is locked. To do this move the steering wheel **Fig. 39-30** in the longitudinal direction.

Adjusting the steering wheel

The steering wheel **Fig. 39-30** can be moved to the relevant driver position using a lever.

- Turn the lever **Fig. 39-B** counter-clockwise until the steering wheel is unlocked.
- Move steering wheel to required position.
- Turn the lever clockwise until the steering wheel is locked.

Check whether the steering wheel is locked. To do this, pull steering wheel **Fig. 39-30** upwards.

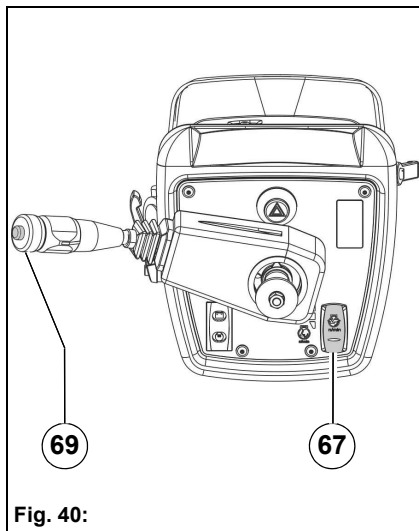


Fig. 40:

Setting the fixed engine speed

The fixed engine speed and thus the system output of the vehicle in the work mode is set with the button **Fig. 40-67**.

Stage	rpm	Hydraulic circuit I Litres/minute	Hydraulic circuit II Litres/minute
1 - ECO	1600	50	20
2 - Standard	2000	50/70	27
3 - Maximum	2400	50/70	32

The overview illustrates that sufficient power is available already in the ECO mode for many applications.

The full hydraulic output is reached as from the Standard speed.

Additional energy is available in the driving mode as well as in hydraulic circuit II at Maximum. Set the speed according to the requirements.

Operation primarily in the ECO mode lowers consumption and noise. See pages 78 and 80 for information about setting the hydraulic circuits.

Horn

The horn is switched on and off with the button **Fig. 40-69**.

- Push the button: horn ON
- Release the button: horn OFF

Switching the hazard warning system on and off

The hazard warning system is switched on and off with the switch **Fig. 41-65**. The direction indicators **Fig. 4-3** and **Fig. 5-18** flash. The hazard warning system also functions in position P of the ignition switch.

- Switch in stage I: hazard warning system OFF
- Switch in stage II: hazard warning system ON

The lamps are monitored. Fast flashing signals a defective lamp.

The warning light information symbol **Fig. 41-C** appears in the multifunctional display.

Direction indicators

The direction indicators **Fig. 4-3** and **Fig. 5-18** are switched on and off with the switch **Fig. 41-69**. The direction indicators also function in position P of the ignition switch.

- Switch in stage I: left direction indicator switch ON
- Switch in stage II: direction indicator switch OFF
- Switch in stage III: right direction indicator switch ON

The lamps are monitored. Fast flashing signals a defective lamp.

In the multifunctional display, the flasher information symbol **Fig. 41-A** appears, or in trailer operation the trailer operation flasher information symbol **Fig. 41-B**.

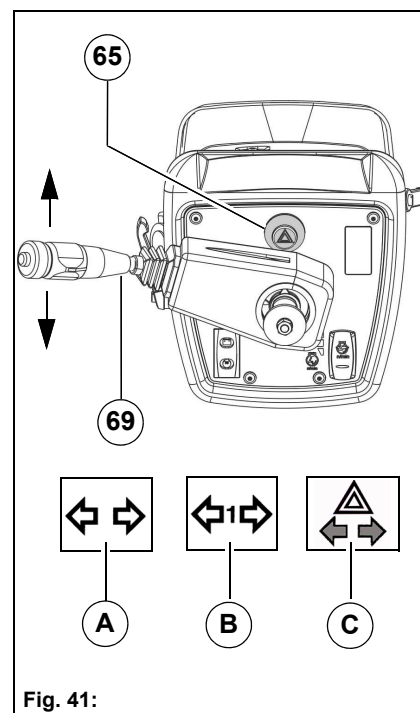


Fig. 41:

Cruise control and speed limiter (optional)

The cruise control and speed limiter is available only in work mode. The current speed is set in the first position of the switch **Fig. 42-72**. In this case the road speed is controlled so that it is not lower or higher than the speed set with the cruise control. The cruise control symbol **Fig. 42-A** appears in the multifunctional display. The cruise control is switched off again in the neutral position of the switch.

If the driver presses the accelerator pedal, the road speed is increased without the cruise control being deactivated. For reasons of safety, the cruise control switches off immediately when the brake pedal is operated.

The speed limiter determines the maximum road speed with the accelerator pedal pushed down fully. This serves for convenient control of the road speed especially at low working speeds. The speed must be set on the configuration menu. It is activated via the second switch position of the switch **Fig. 42-72**.

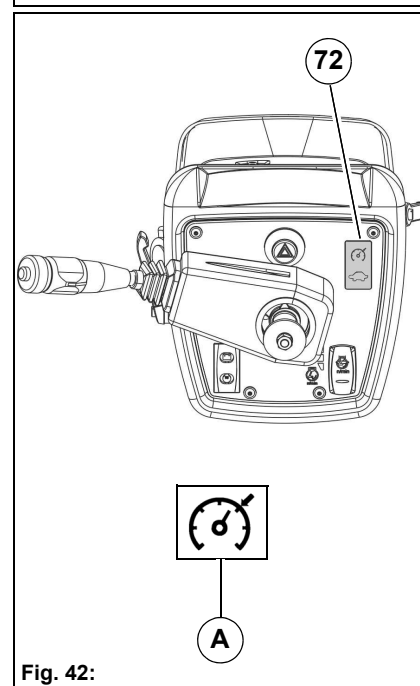


Fig. 42:



Danger

Risk of accident! Use the cruise control and the speed limiter only when the traffic situation allows!

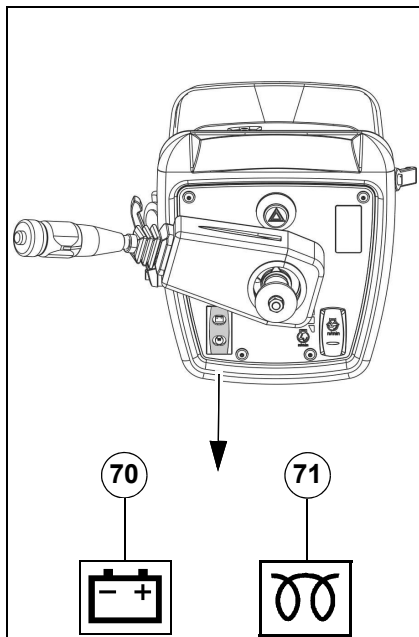


Fig. 43:

Generator control light

The control light of the generator **Fig. 43-70** lights up when the ignition is switched on, but goes out as soon as the engine is started. If the control light goes on when the engine is running, this signals: defect on the V-belt of the generator or defect in the charge circuit of the generator. The battery is no longer being charged! Immediately stop the vehicle safely and if necessary notify an authorised workshop.

Preheat control light

The preheat control light **Fig. 43-71** lights up with the ignition switched on. The engine is preheated until the control light goes out.

If the preheat control light flashes, the preheat procedure has been interrupted and must be repeated.

If the preheat telltale flashes when the key in the ignition switch is in position 1, or during slow or fast operation, an error has occurred in the engine control unit.

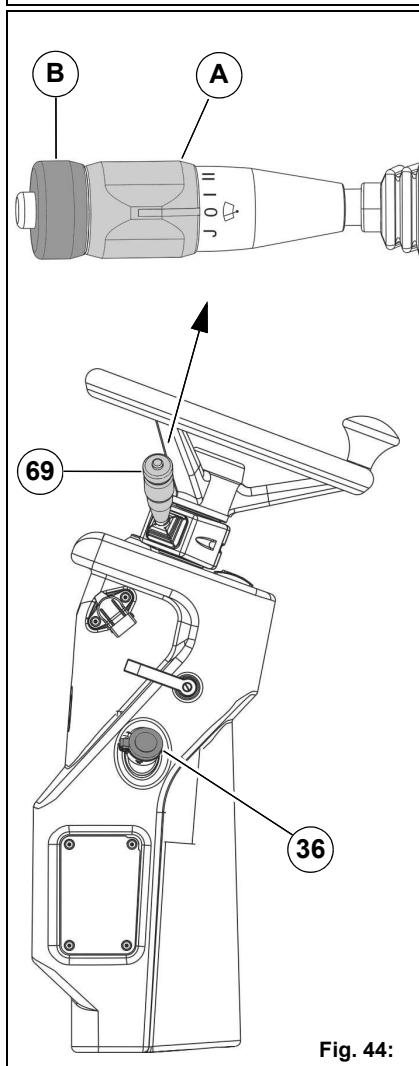



Fig. 44:

Windscreen washer unit

The windscreen washer unit is used for cleaning the windscreen.

The water sprayed onto the windscreen supports the cleaning effect of the windscreen wipers **Fig. 4-6**.

The windscreen washer unit is supplied from the water tank **Fig. 44-36**. Detergents and antifreeze are added to the water as required.

	<p>Note</p> <p>Do not let the windscreen wipers Fig. 4-6 wipe over dry windscreens for a longer time. Wiper blades wear prematurely due to this and the wiper motor can overheat! Switch the windscreen wipers off with dry windscreens.</p>
---	--

The windscreen washer unit is operated using the rotary switch **Fig. 44-A** and the button **Fig. 44-B** of the steering column switch **Fig. 44-69**.

The functions of the rotary switch **Fig. 44-A**:


- Position J: interval ON
- Position 0: OFF
- Position I/II: windscreen wiper ON

The functions of the button **Fig. 44-B**:

- Pressing the button switches the water pump and windscreen wiper on for a brief period.


2.3.3 Left-hand control panel

Switching on fresh water for the suction mouth

	<p>Note Switch the fresh water pump on in the configuration menu before adjusting the fresh water volume, see page 41.</p>
---	---

For binding dust the suction mouth is supplied with water from the circulating water system.

In addition, fresh water can be supplied to the suction mouth as required with the lever **Fig. 45-85** in the left-hand control panel.

	<p>Note Make sure that the ball cock for the circulating water is opened, see page 72.</p>
---	---

Setting the fresh water volume for the sweeping unit

The volume of the fresh water at the spray nozzles is set with the lever **Fig. 45-86** in the left-hand control panel. Set the volume corresponding to the requirements.

- Light contamination: reduce fresh water volume with the lever.
- Heavy contamination: increase fresh water volume with the lever.

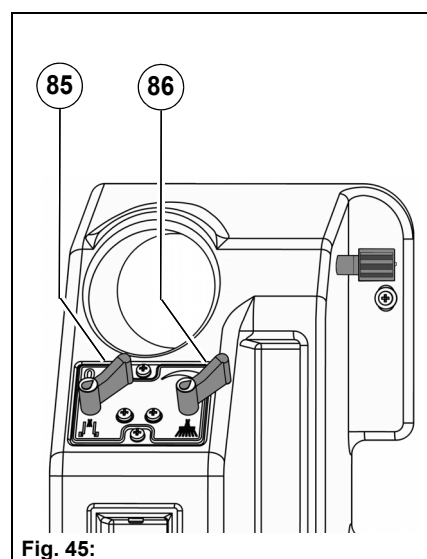



Fig. 45:

2.3.4 Right-hand control panel


Raising and lowering the tipper body

	<p>Danger Danger to life in the danger area of the vehicle! Special caution is required in the area of the raised tipper body.</p>
---	---

The following functions on the tipper body are switched on with the button **Fig. 46-79**:

- Button in position I: tipper body is raised until the button is released.
- Button in position II: tipper body is lowered until the button is released.

As long as the tipper body is not in its lower end position, the tipper body raised warning symbol **Fig. 46-A** appears.

	<p>Note For reasons of safety, the road speed is limited when the tipper body is raised (hopper or load platform)! With the tipper body removed, the warning signal and the road speed limitation must be deactivated for normal travel (configuration menu, vehicle settings, see page 41). Each time the button Fig. 46-79 is pushed, the warning and safety function is switched back on automatically.</p>
---	--

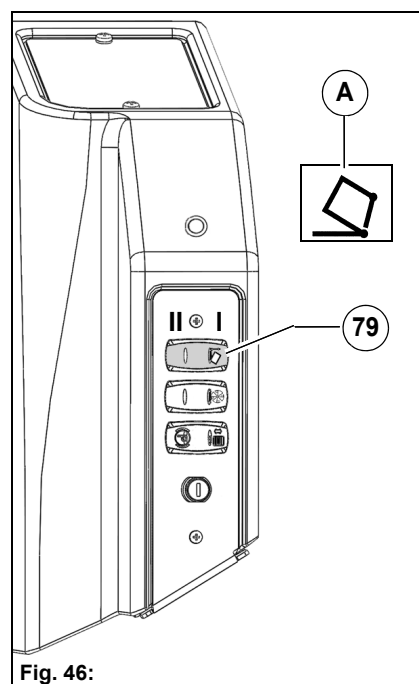


Fig. 46:

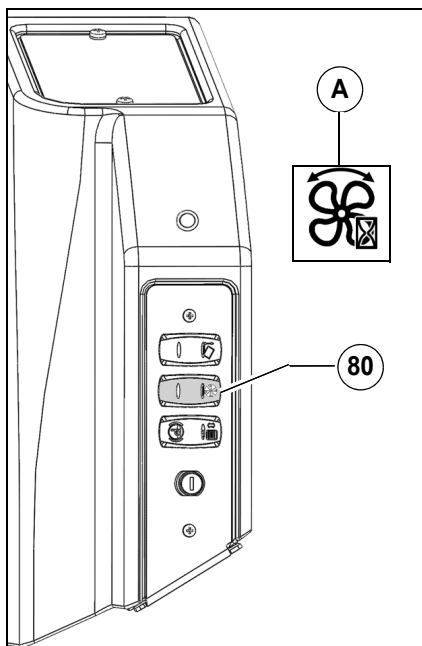


Fig. 47:

Cooling system reversing fan switch (optional)

Should the radiator cover of the cooling system get dirty during sweeping or mowing, it is possible to clean it with the reversing fan. To do this, press the switch **Fig. 47-80**. In this way the reversing fan runs for a certain time in the reverse direction.

- The reversing fan runs for approx. 10 seconds when the button is pressed briefly.
- The reversing fan runs for approx. 30 seconds when the button is pressed longer.

The Reversing fan information symbol **Fig. 47-A** appears in the multifunctional display.

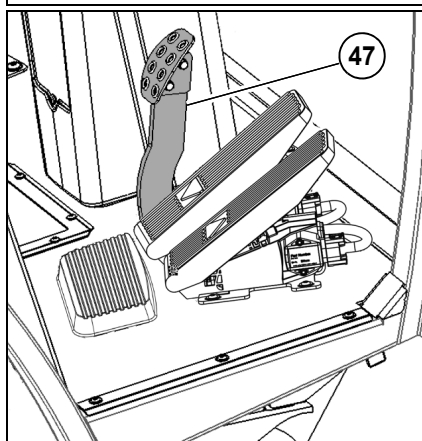


Fig. 48:

Parking brake (electrical) switch

	<p>Danger Risk of accident! Adopt measures against erroneous starting and unwanted movement. Engage the parking brake. Switch the engine off and pull out the ignition key.</p>
--	--

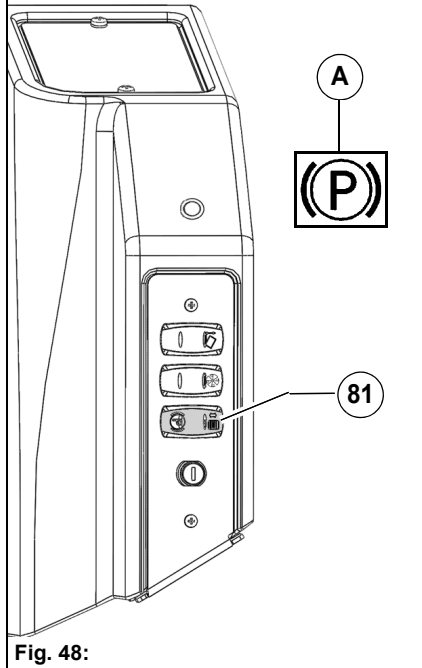
The parking brake **Fig. 48-81** prevents the vehicle from rolling away. If the vehicle still moves, activation of the parking brake is not possible.

Holding the vehicle with the parking brake:

- Push the brake pedal **Fig. 48-47**.
- Unlock the parking brake and press the switch **Fig. 48-81**.
- The warning symbol **Fig. 48-A** appears in the multifunctional display.
- If the accelerator pedal is deflected with the parking brake locked, a warning signal sounds.

Releasing the parking brake:

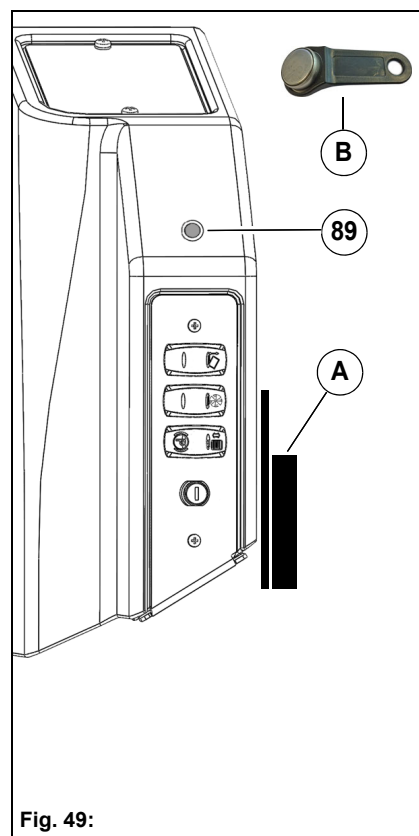
- Press the switch **Fig. 48-81**. The parking brake is released again. With the parking brake released the warning light **Fig. 48-A** goes out.



Fleet-Recorder.x (optional)

The Fleet entry.X **Fig. 49-A** records operating times and further operating conditions of the machine.

- Turn the machine on with the key switch.
 - The red LED of the iButton Reader **Fig. 49-89** lights up.
- Press the iButton Key **Fig. 49-B** against the iButton Reader **Fig. 49-89** for one to two seconds.
 - Red LED OFF.
 - Operating data recording system active.



Ignition switch

**Warning**

- If the engine oil pressure warning symbol **Fig. 50-A** in the multifunctional display lights up with the engine running, there is a risk of engine damage! Stop the vehicle in the safe range. Turn the engine off immediately and check the oil level. Have the cause of the inadequate engine oil pressure removed.

**Note**

- The engine can be started only if the accelerator pedals **Fig. 6-38** and **Fig. 6-39** are in neutral position and the brake pedal **Fig. 48-47** is depressed.
- The ignition switch **Fig. 8-82** has a start repeating interlock. Switch back to position 0 for a further start.
- Do not repeat the starting procedure more than 3 times, then let the starter cool down.
- After starting the cold engine, let it warm up with slightly increased idling speed.
- At temperatures below 10 °C, the engine speed is electronically limited to prevent damage to the hydraulic system. Above 10 °C the permissible engine speed is increased linearly up to 30 °C. Above 30 °C hydraulic oil temperature, the maximum engine speed is available.
- Do not actuate the accelerator pedal during the starting procedure!

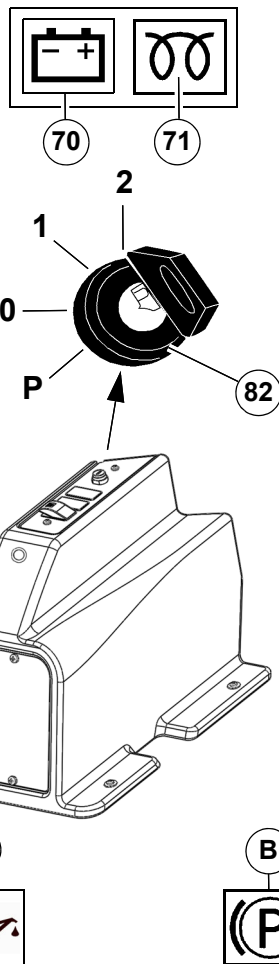


Fig. 50:

The ignition switch **Fig. 8-82** is used for starting the engine and for switching the electrical system on and off.

- Position P: the emergency flasher light, side lights, rotating beacon, number plate light, rear fog light (optional) and interior light are functioning. The key can be pulled out. Position P can be reached from position 0. Push the key down and then turn it to the left.
- Position 0: the emergency flashing light is functioning. The electrical system and the engine are switched off. The key can be pulled out.
- Position 1: the electrical system and the engine are switched on.
 - The parking brake warning symbol **Fig. 50-B** in the multifunctional display may light up.
 - The generator control light **Fig. 52-70** lights up briefly and goes out after the engine has started and has sufficient engine speed.
 - The preheat control light **Fig. 52-71** lights up, the engine is preheated until the control light goes out.
- Position 2: start the engine.
 - The parking brake warning light may light up.
 - Warning lights must go out.
 - If the preheat control light flashes when the key in the ignition switch is in position 1, or during operation slowly or fast, then a fault in the engine control has occurred. Refer to troubleshooting on page 93 or contact an authorised Hako dealer.
 - If a service information is displayed in the multifunctional display with a flashing wrench then there is an error. Refer to troubleshooting on page 93 or contact an authorised Hako dealer.
- The ignition switch goes back into position 1.

2.3.5 Arm rest control panel

Hako button

The Hako button **Fig. 51-76** switches from transport mode to work mode or vice versa and starts automated procedures according to the attachment.

The accelerator pedals must be in the neutral position.

In the multifunctional display, the transport mode **Fig. 51-A**, or front tool carrier symbol **Fig. 51-B** appears.

The vehicle speed in the:

- transport mode is 0 to 40 km/h,
- work mode 16/20/27 km/h according to selected engine speed.

You will find the functional description of the Hako button for attachments in chapter 6.

Joystick

The front tools are operated with the joystick **Fig. 51-74** and the joystick **Fig. 51-75**.


The joystick **Fig. 51-74** acts on the front tool carrier **Fig. 51-12** and on the hydraulic connections **Fig. 51-11A**.

- Joystick forwards: lowering front tool carrier (floating position)
- Joystick back: raising front tool carrier
- Joystick to the left: the left-hand actuator swings to the left
- Joystick to the right: the left-hand actuator swings to the right

In the multifunctional display, the upper stop information symbol **Fig. 51-C** or floating position symbol **Fig. 51-D** appears.

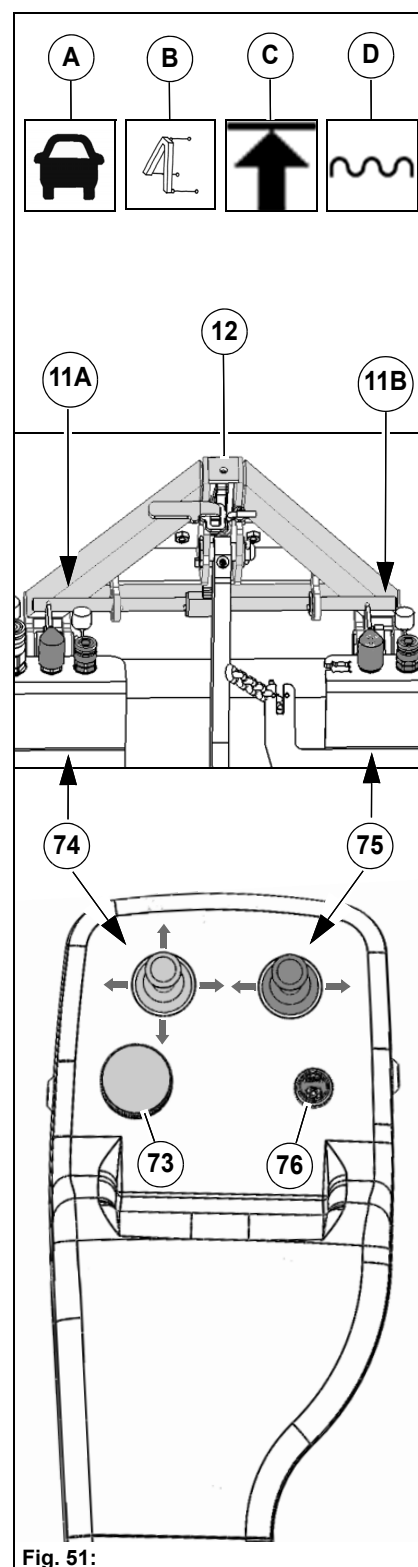
The joystick **Fig. 51-75** acts on the hydraulic connections **Fig. 51-11B**.

- Joystick to the left: the right-hand actuator swings to the left
- Joystick to the right: the right-hand actuator swings to the right

	<p>Note</p> <ul style="list-style-type: none"> • For reasons of safety, lowering the front tool carrier with the vehicle moving is possible only in the work mode. In the transport mode, the front tool carrier can be lowered only at a road speed of <math>< 5\text{ km/h}</math>. • If the front tool does not have to be lowered completely, interrupt the lowering movement by briefly pulling the joystick back. • If the movement of the front tool does not agree with the movement of the joystick, change over the hydraulic connections.
---	---

Turn-push knob

The turn-push knob **Fig. 51-73** is located in the right armrest of the driver's seat. Menus and submenus are selected in the multifunctional display and the individual menu item values are set or changed with the turn-push knob, see page 34.



2.3.6 Roof control panel

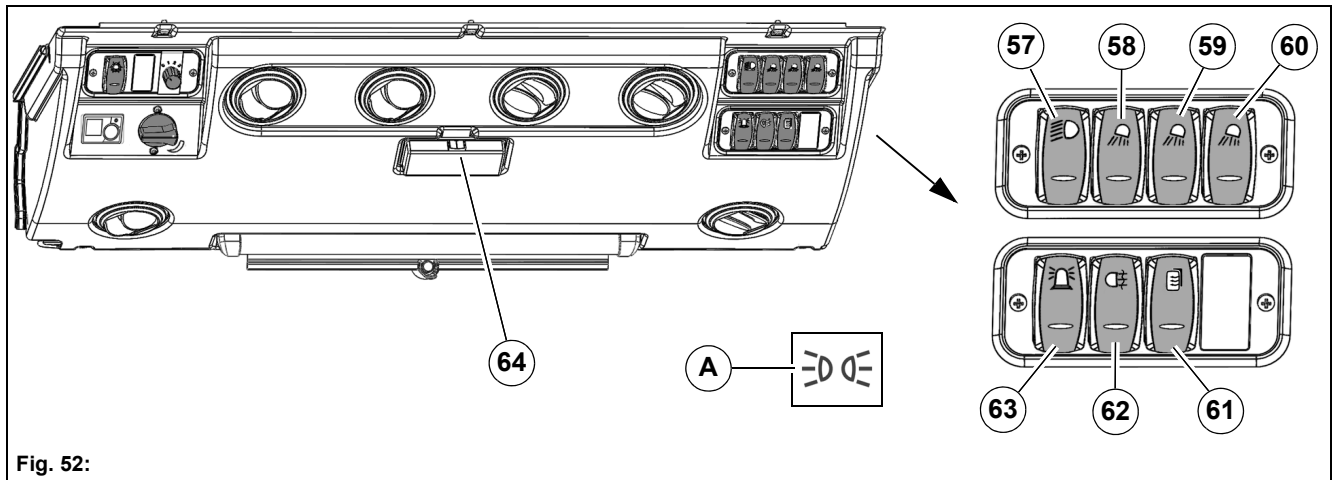


Fig. 52:

Dipped headlight and side lights

The switch Fig. 52-57 switches the dipped headlight Fig. 4-2, the side lights Fig. 4-3 and the number plate light Fig. 4-16 on and off.

With the multifunctional display switched on, the dipped headlight and side lights information symbol Fig. 52-A appears.

Working light

The switch Fig. 52-58 switches the working light Fig. 4-13 in the front work area on and off.

The switch Fig. 52-59 switches the working light Fig. 4-14 in the work area behind the cab (optional) on and off.

The switch Fig. 52-60 switches the working light Fig. 4-15 in the work area of the suction mouth (optional) on and off.

Outside mirror heating (optional)

The switch Fig. 52-61 switches the outside mirror heating (optional) on and off.

Rear fog light (optional)

The switch Fig. 52-62 switches the rear fog light (optional) on and off.

Rotating beacon

The rotating beacon Fig. 4-4 is switched on and off with the switch Fig. 52-63. The rotating beacon also functions in position P of the ignition switch.

Interior lighting

The interior lighting is switched on and off with the switch Fig. 52-64.

2.3.7 Accelerator pedal

Accelerator pedal for forwards and reverse

The accelerator pedals **Fig. 53-38** for forwards **Fig. 53-39** and for reverse are used for continuously changing the road speed. Push the accelerator pedal down to increase the driving speed. If you release the accelerator pedal, it goes back automatically to zero position, the vehicle stops. The warning symbol **Fig. 53-A** appears in the multifunctional display.

In forwards gear up to a speed of approx. 15 km/h the vehicle is in speed level 1. The warning symbol **Fig. 53-B** appears in the multifunctional display.

If the temperature of the hydraulic oil is below 20 °C, the vehicle remains in speed level 1 and the information symbol flashes.

Above a speed of approx. 20 km/h the vehicle is in speed level 2

Fig. 53-C.

This can be delayed depending on the acceleration and the load. In this case the information symbol flashes.

If the accelerator pedal signal is not plausible, the information symbol flashes in the multifunctional display **Fig. 53-D.**

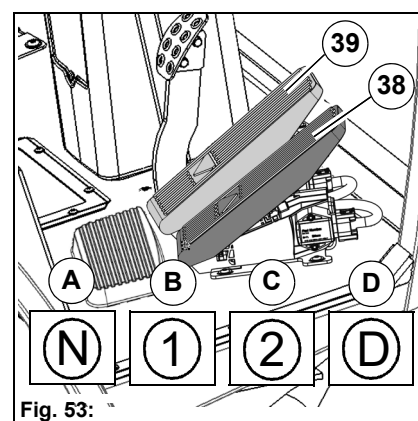


Fig. 53:

2.3.8 Brake

When the accelerator pedal is released (forwards or reverse) the vehicle comes to a stop quickly because of the hydrostatic braking effect. If this braking effect is not sufficient, the brake **Fig. 54-47** must be applied in addition.



Danger

- Risk of accident! When operating at special altitudes (above 3,000 metres), the power of the engine or the engine brake decreases. Adapt your mode of operation and driving style accordingly.
- Risk of accident! Note that dirty pedals can impair the braking effect!

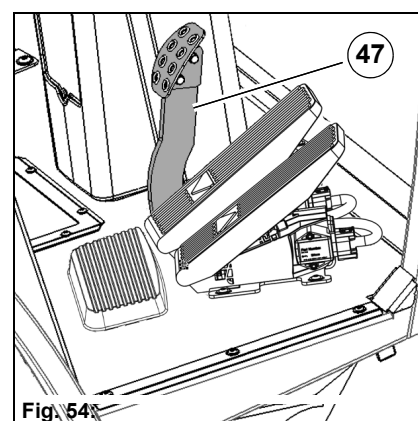


Fig. 54:

2.3.9 Coarse material flap

Operating the coarse material flap

If there are larger objects or coarse dirt (cans, bottles, leaves, etc.) in front of the suction mouth, you can open the coarse material flap on the suction mouth by pressing down on the pedal **Fig. 55-48**.

The pedal can be locked by shifting it to the right when it is operated.

Pushing and shifting the pedal to the left with your foot will unlock it.



Note

- The coarse material flap pedal **Fig. 55-48** cannot be operated with the suction mouth raised!
- The coarse material flap must be closed again after picking up the coarse material. Fine sand is not taken up if the coarse material flap is open.

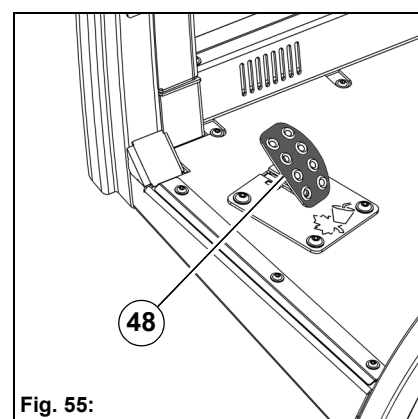



Fig. 55:

2.3.10 Driver's seat

The driver's seat **Fig. 56-46** is air-cushioned. To reach the controls easily, the right armrest, height and longitudinal setting can be adjusted. If the driver leaves the driver's seat during operation, then the driver's seat warning symbol **Fig. 56-A** in the multifunctional display flashes. The warning symbol goes out as soon as the driver is back on the driver's seat.

	<p>Danger</p> <ul style="list-style-type: none"> • Risk of accident! Adjust the driver's seat only when the vehicle is stationary. You will otherwise be diverted from the traffic and could lose control over the vehicle by moving the seat. You could cause an accident by this. <p>Warning</p> <ul style="list-style-type: none"> • For reasons of safety, the vehicle is equipped with a seat contact switch and the function of the seat contact switch must not be bypassed.
---	---

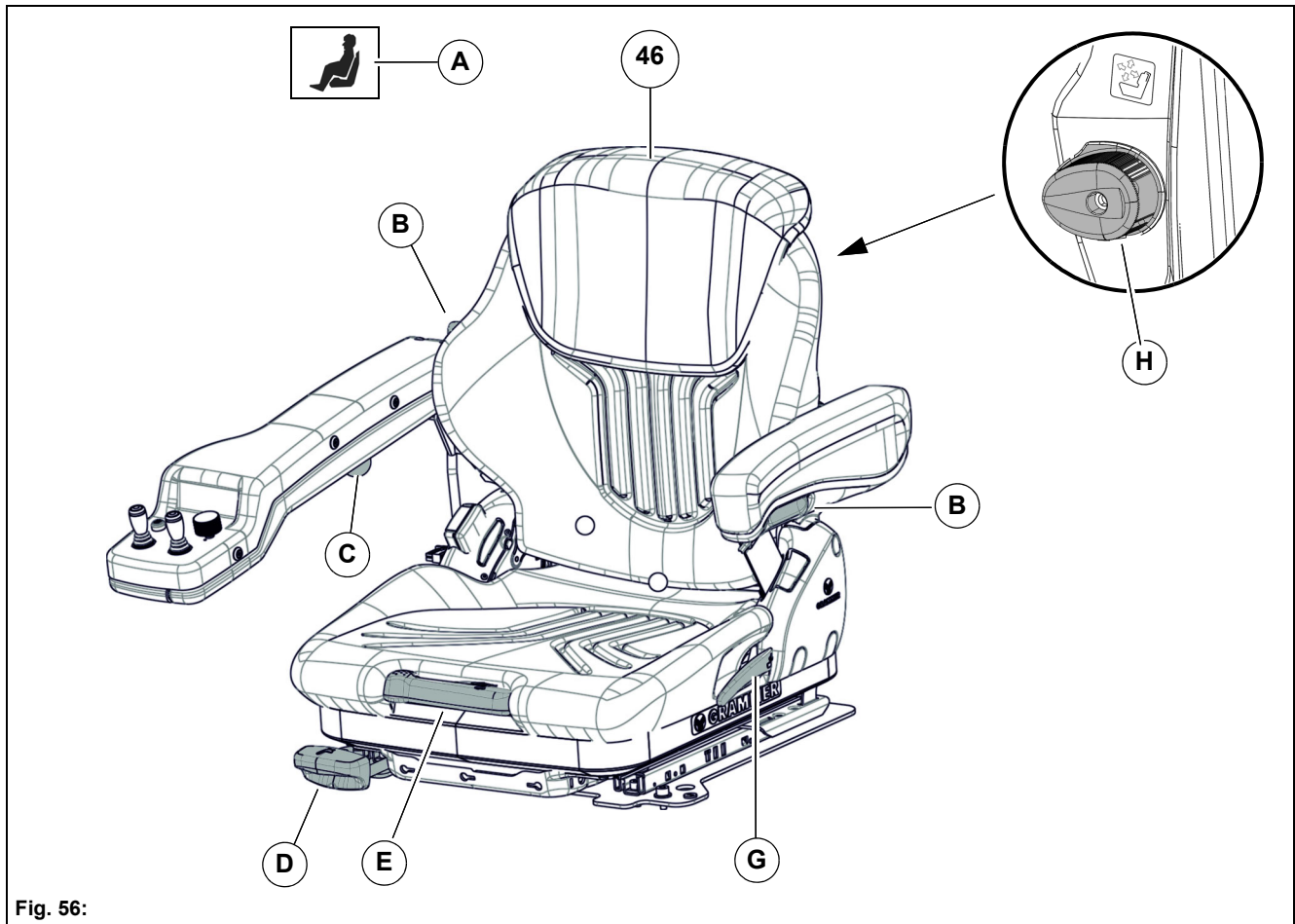


Fig. 56:

Adjusting the armrest

The armrest can be folded and its inclination can be adjusted. Turn the wheel **Fig. 56-B** to adjust the inclination. The right armrest can be unlocked with the lever **Fig. 56-C**.

Lever for longitudinal adjustment

Adjust the seat in the longitudinal direction with the lever **Fig. 56-D**.

- Pull lever up = seat unlocked. Set the seat forwards or backwards.
- Let the lever snap back after the adjustment.

Weight adjustment

For optimum suspension, the driver's seat must be adjusted to the weight of the driver with the knob **Fig. 56-E**.

- Pull knob up = increase driver's weight.
- Pull knob down = decrease driver's weight.

The suspension is adjusted optimally if the indicator is in the middle.

Adjusting the backrest

Adjust the backrest with the lever **Fig. 56-G**. You should be on the driver's seat for the adjustment.

- Pull the lever up with you left hand.
- Move the backrest back (inclined position) by leaning your upper body back.
- Move the backrest forwards (vertically) by leaning your upper body forwards.
- Let the lever go when you have reached the optimum position of the backrest, the lever then snaps back into the desired position.

Spine support adjustment

Turn the wheel **Fig. 56-H** of the backrest to adjust the spine support.

2.3.11 Seat belt

The seat belt **Fig. 57-43** serves for the safety of the driver. The seat belt assures complete freedom of movement when pulled slowly. However, it is blocked in sudden braking. The seat belt can also be blocked when driving over potholes or other bumps in the road.



Danger

Risk of accident! A dirty, damaged seat belt or one stressed or changed in an accident may not offer the intended protection. You could therefore suffer severe injuries or death in an accident. Please check regularly that the seat belts are not damaged and not contaminated. Always have damaged seat belts or those stressed in an accident renewed by an authorised workshop.

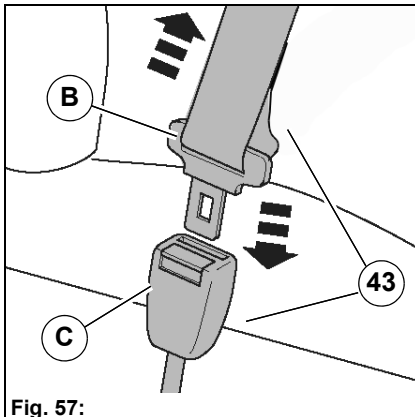


Fig. 57:

Putting seat belts on and off

Insert the buckle latch **Fig. 57-B** into the belt buckle **Fig. 57-C** until it snaps in audibly (check by pulling). Tension the seat belt by pulling on the end. The seat belt must always lie firmly against your pelvis.

Make sure you are sitting upright and the belt runs correctly!

To take off the seat belt hold it firmly and press the red button on the belt buckle **Fig. 57-C**. Guide the seat belt slowly up to the reel.

2.3.12 Cab heating



Danger

Risk of accident! Good viewing conditions contributing to traffic safety are guaranteed only if all windows are free of ice, snow and condensation. Make yourself familiar with the correct operation of the heating and ventilation system as well as de-moisturising/defrosting the windows. Maximum heating power and fast thawing of the windows can be achieved only if the engine has reached its operating temperature.

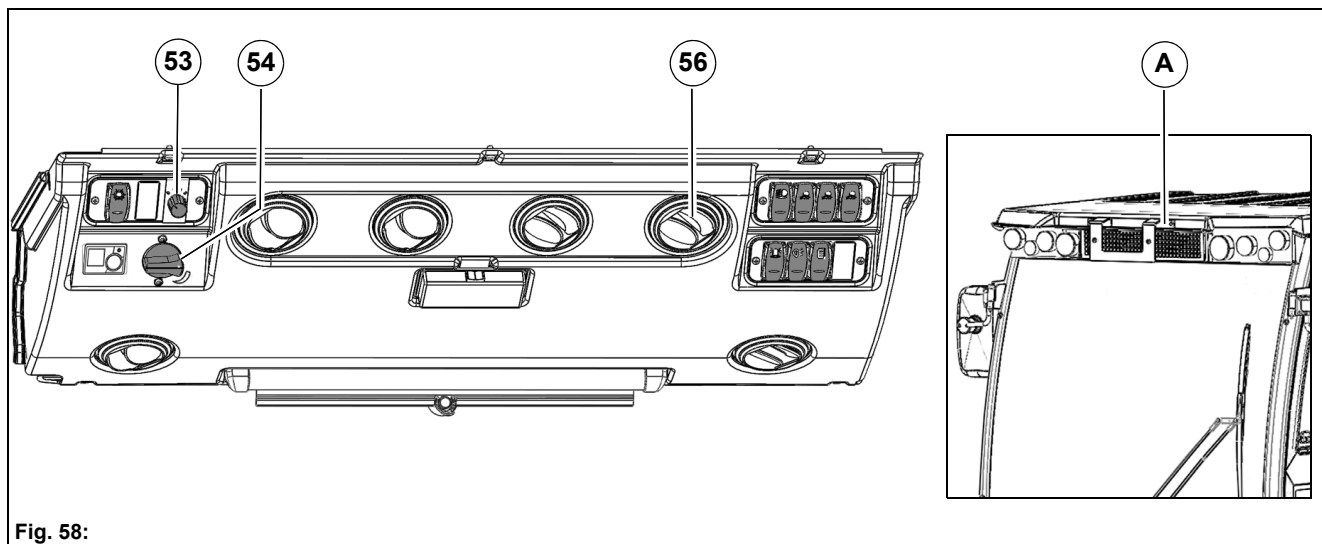


Fig. 58:

The vehicle is equipped with cab heating. Two operating conditions can be selected with the cab heating:

- Ventilation
- Heating

The air flow is transported by a 3-stage suction fan to the air vents

Fig. 58-56 of the windscreen and through the air vents **Fig. 6-49** of the foot well into the driver's cab.

Adjusting the ventilation

The ventilation is set with the controller **Fig. 58-53**.

- Controller in position 0: suction fan OFF
- Controller in position 1: suction fan runs in stage 1
- Controller in position 2: suction fan runs in stage 2
- Controller in position 3: suction fan runs in stage 3

Setting the temperature

The temperature is set with the controller **Fig. 58-54**.

- Setting warmer: turn the controller counter-clockwise
- Setting colder: turn the controller clockwise

Cab air filter

The installed cab air filter **Fig. 58-A**, which is located beneath the number plate holder **Fig. 4-16**, filters out largely dust and pollen. A clogged filter reduces the air supply into the vehicle interior. Therefore please observe the filter changing intervals, see page 115.

2.3.13 Air conditioning system



Danger

Risk of injury! The coolant in the air conditioning system is under high pressure. Do not open any parts of the air conditioning system. Have maintenance work on the air conditioning system done only by authorised workshops.

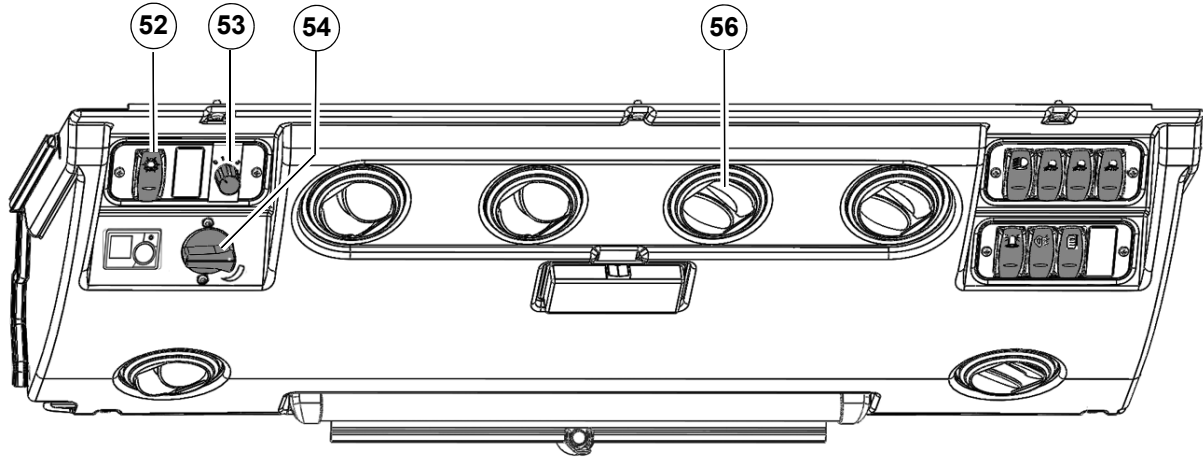


Fig. 59:

The air conditioning system regulates the temperature and humidity of the vehicle interior and filters unwanted substances out from the air.

The air conditioning system is operational only when the engine is running. It functions optimally only if the side windows are closed.

The air flow is transported by a 3-stage suction fan to the air vents

Fig. 59-56 of the windscreen and through the air vents **Fig. 6-49** of the foot well into the driver's cab.

In warm weather ventilate the vehicle for a short time only. In this way you accelerate the cooling process and the desired vehicle interior temperature is reached faster.

Observe the recommended setting, otherwise the windows can mist over. Switch the air conditioning off only briefly and the circulating air on only briefly.

Switching the air conditioning on

- Switch the air conditioning on with the switch **Fig. 59-52**. The control light on the switch goes on.
- Set the air supply on the controller **Fig. 59-53**.
- Set the temperature with the controller **Fig. 59-54** to 18 °C to 22 °C.

2.3.14 Doors



Danger

- There is a risk of accidents when driving with open doors **Fig. 60-7!** The doors must remain closed when driving on public roads and when working.
- The outside mirrors **Fig. 58-5** image reduced in size. The visible objects are closer than they appear. Thus you can incorrectly estimate the distance from road users driving behind you, e.g. when changing lanes. There is a risk of accidents! Therefore check the actual distance from road users driving behind you by glancing over your shoulder.

Opening doors from the outside

To open the doors **Fig. 60-7** insert the key in the door lock **Fig. 60-A**, turn it counter-clockwise and push it.

Opening doors from the inside

To open the doors pull the lever **Fig. 60-B** upwards.

Adjusting the side windows

The left and right side windows are opened or closed with the catches **Fig. 60-C**. Push the catch up and move the window correspondingly.

Outside mirrors

You have an extended field of view due to the convex outside mirrors **Fig. 60-5**.

Adjusting the outside mirrors

Adjust the outside mirrors so that the roadway and the rear work area are completely visible.

The outside mirrors can be folded down.

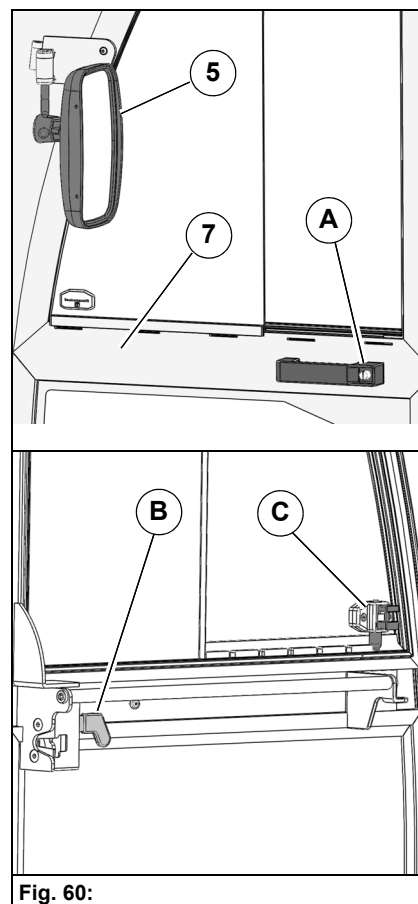


Fig. 60:

2.4 Operating equipment of the vehicle

2.4.1 Auxiliary tools

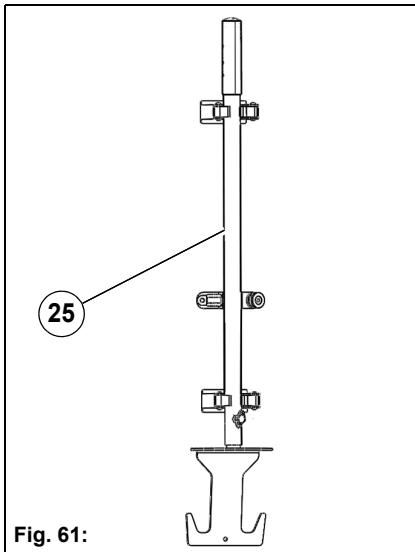


Fig. 61:

The auxiliary tool **Fig. 61-25** is located on the driver's cab at the rear on the right. This auxiliary tool has the following functions:

- For mounting the suction mouth, see page 130.
- For removing coarse dirt from the suction mouth and suction duct, see page 155.
- For cleaning the dirt hopper, e.g. if leaves clog up the sieves, see page 156.
- As lever for the hand pump of the rear structure (optional). For raising the dirt hopper/loading platform in the case of an engine failure.
- For releasing the parking brake on the rear axle.

2.4.2 Ball cock circulating water

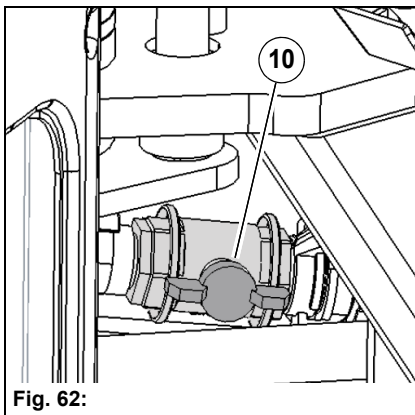


Fig. 62:

The circulating water is closed off only with the ball cock **Fig. 62-10** for maintenance purposes. In normal operation the ball cock must be opened!

- Circulating water supply opened: ball cock in flow direction.
- Circulating water supply closed: ball cock at right angles to the flow direction.



Note

Close off the circulating water supply only if there is circulating water in the dirt hopper and the suction mouth should be mounted or dismounted, see page 130.

2.4.3 Front tool carrier

The front tool carrier **Fig. 63-12** is used for holding an attachment.



Danger

Risk of accident! Front attachments not correctly fastened to the front tool carrier can drop down while driving. Always secure the front attachment with the locking devices **Fig. 63-A and B**. Always secure non-Hako tools with the locking device **Fig. 63-C**.

Taking up the front tool

- 1 Drive the vehicle up to the attachment and lower the front tool carrier with the joystick **Fig. 63-74**.
- 2 Bring the locking hook **Fig. 63-A** into the rear position and the lever **Fig. 63-B** into the upper position (II). Remove the chain **Fig. 63-D** and hook it onto the hook **Fig. 63-E**.
- 3 Drive under the take-up of the attachment and carefully raise the attachment with the joystick **Fig. 63-74**. Raising the front tool carrier is interrupted if the driver leaves the driver's seat.

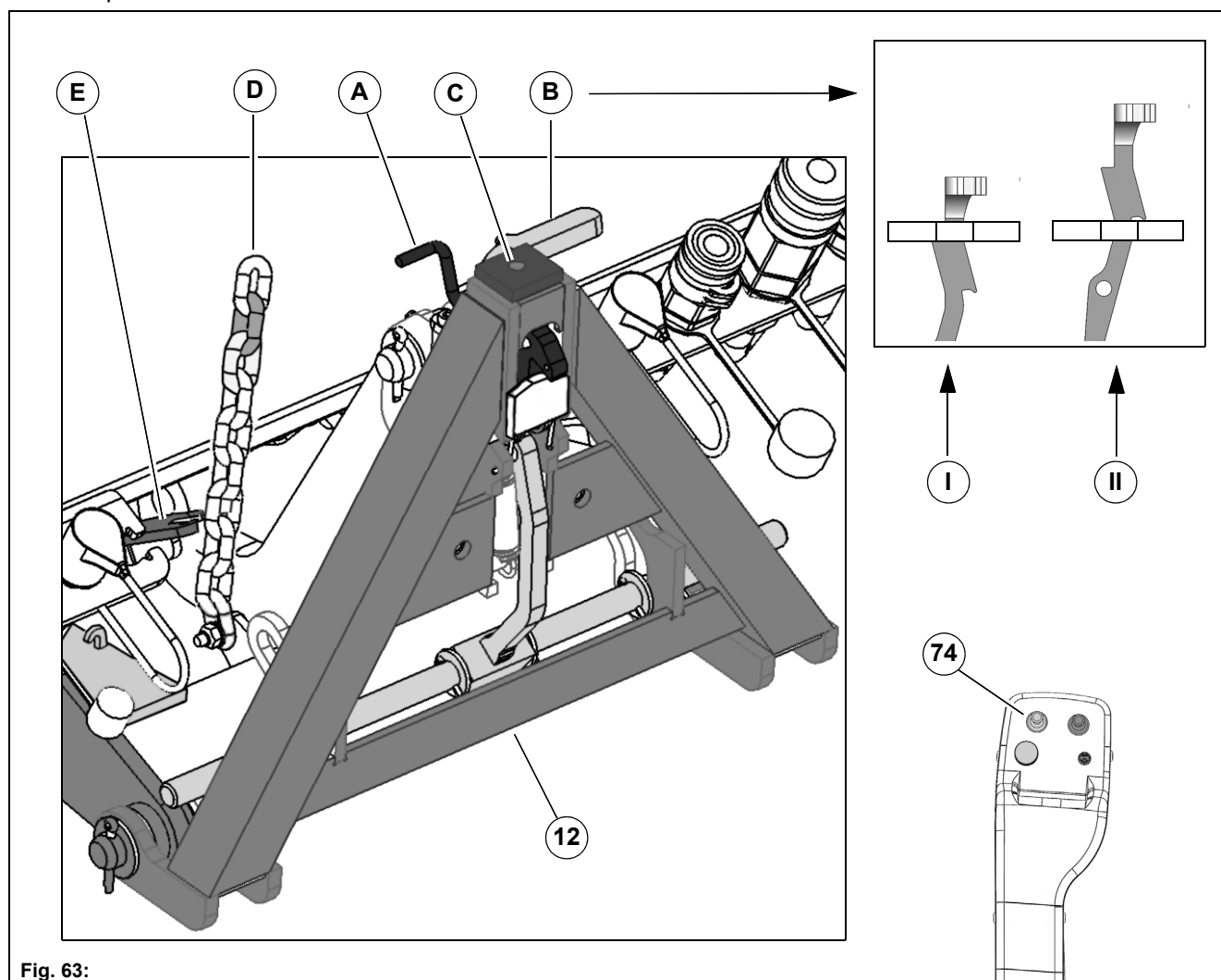


Fig. 63:

Securing the front tool

1. Bring the locking hook **Fig. 64-A** into the front position and the lever **Fig. 64-B** into the lower position **(I)**.
2. Adjusting the movement limiter of the front tool carrier:
 - For vacuum sweeping, hook the chain **Fig. 64-D** onto the holder **Fig. 64-E**. Observe the hooking point **Fig. 64-F!**
 - For attachments with floating position, the chain must be hooked onto the hook **Fig. 64-G!** (parking position)!
3. Check the locking plate **Fig. 64-H** on the attachment. If necessary, loosen the screws and shift the locking plate.

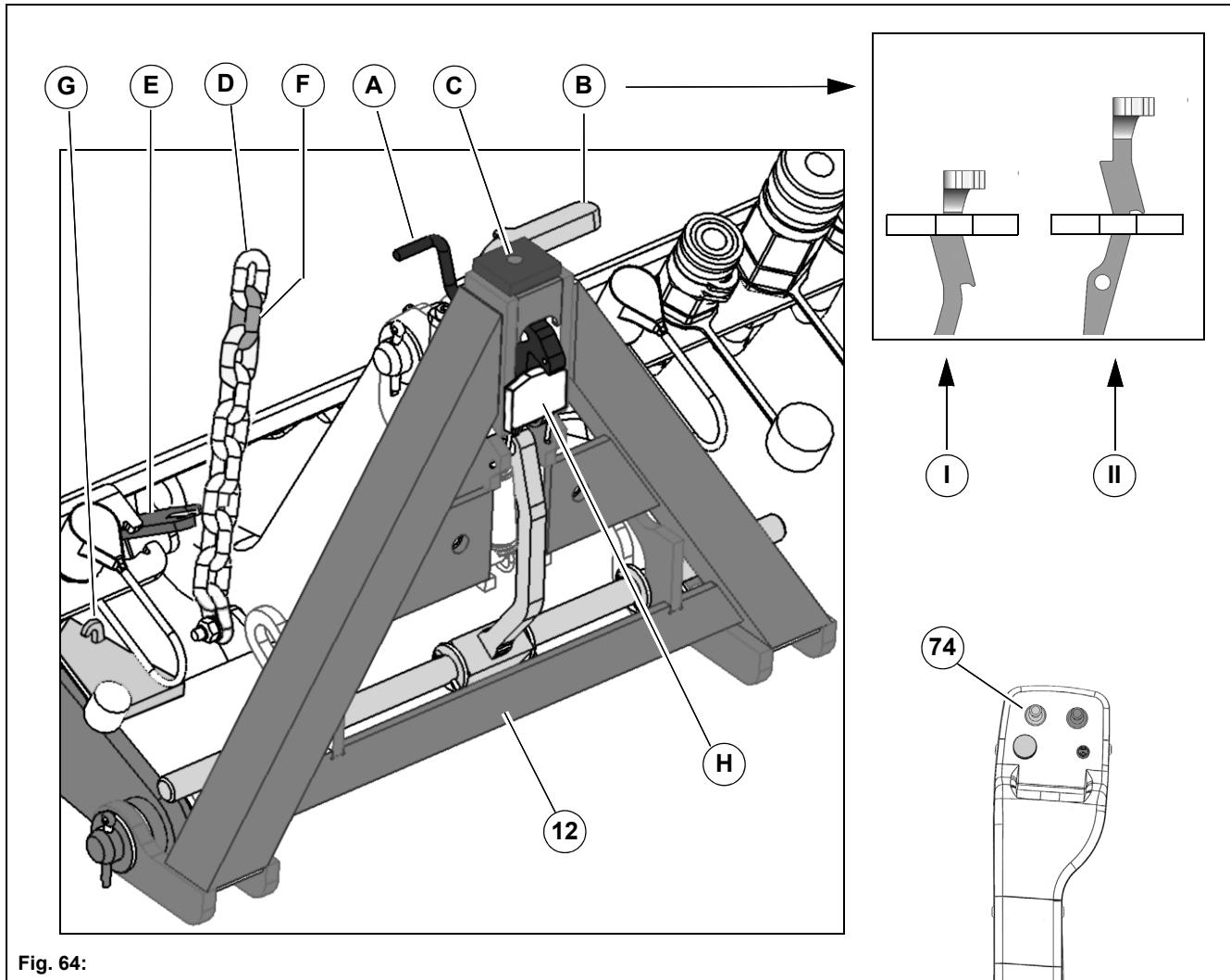


Fig. 64:

Relief of the front tool carrier (optional)

Using this option, it is possible to reduce the brush pressure of the attachment.

Select the working menu in the multifunctional display with the turn-push knob **Fig. 65-73**. Change the current value in the relief menu item **Fig. 65-A**.

The higher the setting, the more the front tool is relieved.

Setting range: 0 to 100%

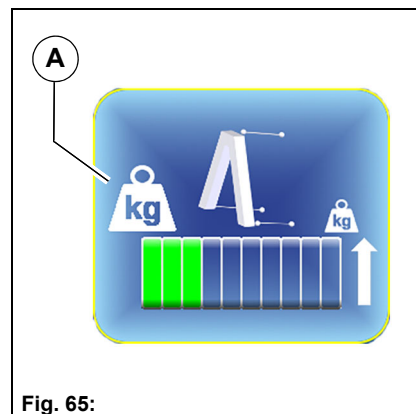


Fig. 65:

Switching the water pump on and off

Select the working menu in the multifunctional display with the turn-push knob. Change the current value in the fresh water menu **Fig. 66-A**.

Setting range: On/Off

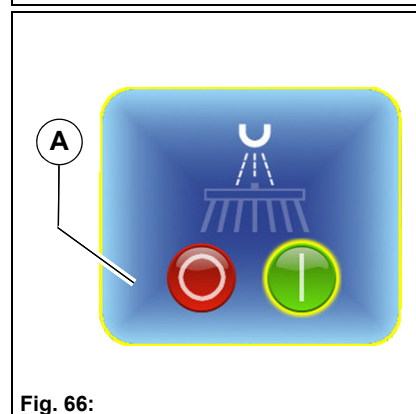


Fig. 66:

Setting the fresh water volume

The fresh water volume is set with the lever **Fig. 68-86**.

Setting the lowering speed of the front tool carrier

The lowering valve **Fig. 68-88** is used to adjust the lowering speed of the front tool carrier.

- Turn the lowering valve clockwise = lowering speed lower
- Turn the lowering valve counter-clockwise = lowering speed higher

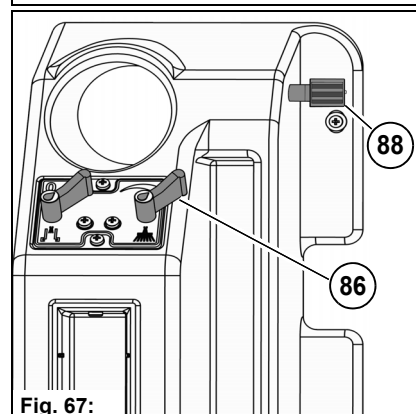


Fig. 67:

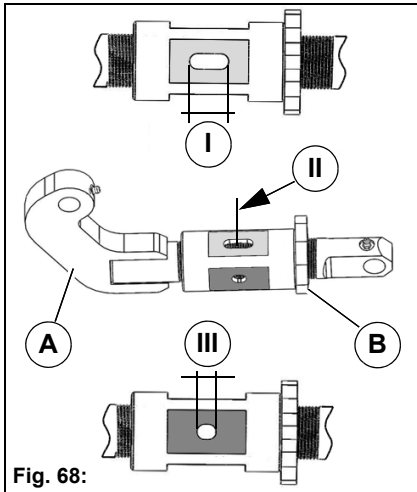


Fig. 68:

Adjustable upper link (optional)

The adjustable upper link **Fig. 68-A** is provided for the fine adjustment of attachments and for simplified take-up of attachments with conventional A-frames type 0. Loosen the nut **Fig. 68-B** and adjust the middle section with a suitable tool to the required length. Then secure with the nut **Fig. 68-B**.

- Turn the middle section clockwise = the front tool carrier inclines to the front
- Turn the middle section counter-clockwise = the front tool carrier inclines to the back

Maximum **(I)**: the spindle touches the edges of the long elongated hole.

Minimum **(II)**: both spindles are flush.

Standard length **(III)**: the spindle touches the edges of the short elongated hole.



Note

When the sweeping system is used, adjustment to position III **Fig. 68** is required for correct operation of the sweeping unit.

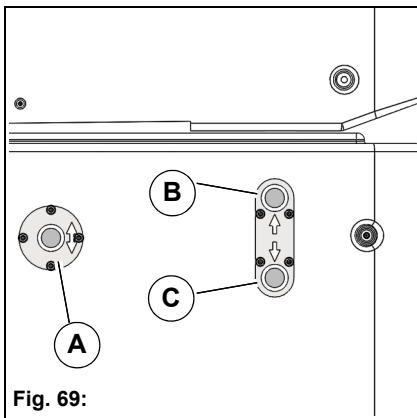


Fig. 69:

Lift system tipper body (optional)

With the optional lift system tipper body, additional controls for raising or lowering the tipper body are located on the left side of the rear wagon.



Danger

Risk of crushing! When carrying out work on the tipper body, always operate the controls in two-handed operation.

- Raise tipper body: press the button **Fig. 69-A** and the button **Fig. 69-B** simultaneously
- Lower tipper body: press the button **Fig. 69-A** and the button **Fig. 69-C** simultaneously

2.4.4 Connections for front attachments



Note

The hydraulic couplings are marked with coloured rings and engraving, see example **Fig. 70-C2**.

The following devices can be operated with the connections for the front attachments **Fig. 70-12**:

- **A** = Supply for optional 3-brush system (red/P)
- **A2** = Load sensing for option 3-brush system (blue/LS)
- **B** = water connection for sweeping unit spray nozzles
- **C1** = Return of right-hand actuator (green/-)
- **C2** = Supply for right-hand actuator (green/+)
- **D1** = Return of left-hand actuator (red/-)
- **D2** = Supply for left-hand actuator (red/+)
- **E** = Return of leakage oil pipe (e.g. for front mower) (black/L)
- **F1** = Return maximum 70 litres/min (hydraulic circuit I) (black/T!)
Setting the output, see page 78.
- **F2** = Supply maximum 70 litres/min (hydraulic circuit I) (blue/P)
Setting the output, see page 78.
- **G** = ball cock for the suction mouth lift system
- **X63** = 19-pin socket for front attachments



Attention

If the suction mouth lift system is not needed for an attachment, the suction mouth lift system must be raised and blocked in the uppermost position using the ball cock!

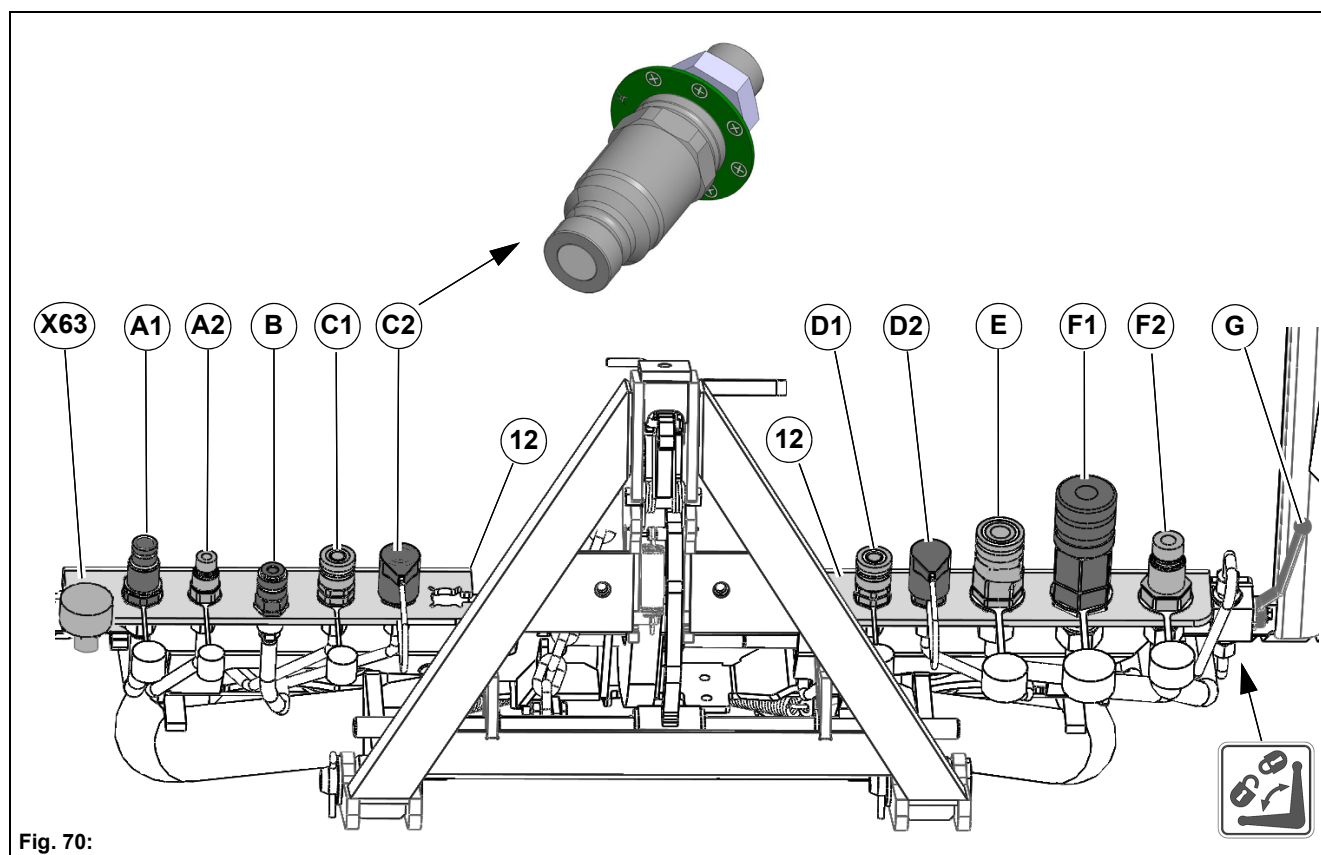
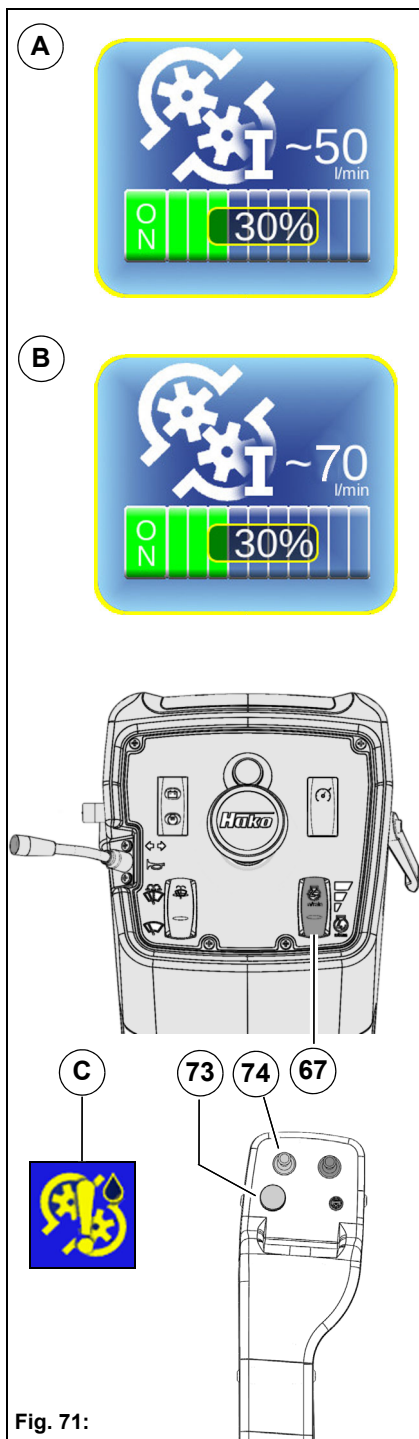


Fig. 70:



Output setting for hydraulic circuit I

The maximum delivery of hydraulic circuit I is determined by the coding plugs on the attachment. Two selectable oil flows with a maximum flow of 50 l/min (Fig. 71-A) or 70 l/min (Fig. 71-B) are available for attachments without coding plugs. The adjustment is made on the configuration menu, see page 41.

In the working menu, the hydraulic circuit I Fig. 71-A is activated and set to the required value with the turn-push knob Fig. 71-73. Setting range: OFF/ON or 0 to 100% In the setting to 70 l/min the adjustment process stops initially at 70% (corresponds to 50 l/min setting), but can be continued by renewed turning of Fig. 71-73 up to 100% (70 l/min).

	<p>Danger Risk of injury! Make sure that the attachments are suitable for the set oil volume. An oil volume set too high can lead to injuries due to a defect of the attachment! As a reminder, the setting process is interrupted briefly at 70%.</p>
--	---

	<p>Note The hydraulic circuit I is switched off if the driver leaves the driver's seat. The driver switches the hydraulic circuit I back on with Fig. 71-73 after returning to the driver's seat. In connection with the sweeping unit and the universal hopper, the brush is restarted by pushing the left joystick Fig. 71-74 to the front!</p>
--	--

	<p>Note The delivery of hydraulic circuit I depends to a large extent on the engine speed set on the tip switch Fig. 71-67. Select the ECO mode as often as possible in the sense of the most energy-saving operation of the vehicle. If the oil flow requested by Fig. 71-73 does not reach the set value, then the warning Fig. 71-C appears in the multifunctional display. Cancel the adjustment or increase the engine speed until the warning symbol goes out. Also increase the engine speed if you require additional power for driving (e.g. driving uphill or propulsion work in winter service). If the additional power requirement is no longer required, reduce the power step by step.</p>
--	--

Fig. 71:

2.4.5 Connections for rear attachments



Note

The hydraulic couplings are marked with colour coding and engraving, see example **Fig. 72-B2**.

The following devices can be operated with the connections for the rear attachments **Fig. 72-20**:

- **X64** = 7-pin socket for rear attachments
- **A1** = Return maximum 35 litres/min (hydraulic circuit II) (black/T)
Setting the output, see page 80.
- **A2** = Supply maximum 35 litres/min (hydraulic circuit II) (red/P)
Setting the output, see page 80.
- **B1** = Return of hopper lift system hydraulic cylinder (green/-)
- **B2** = Supply of hopper lift system hydraulic cylinder (green/+)
- **C** = Dirt hopper circulating water
- **D** = Fresh water for high-pressure cleaner (optional)
- **E** = Connection of the dirt hopper vacuum indicator (optional)
- **X65** = 7-pin socket for lights
- **X68** = 7-pin socket for spreader control cable
- **X67** = 12-pin socket for spreader control cable

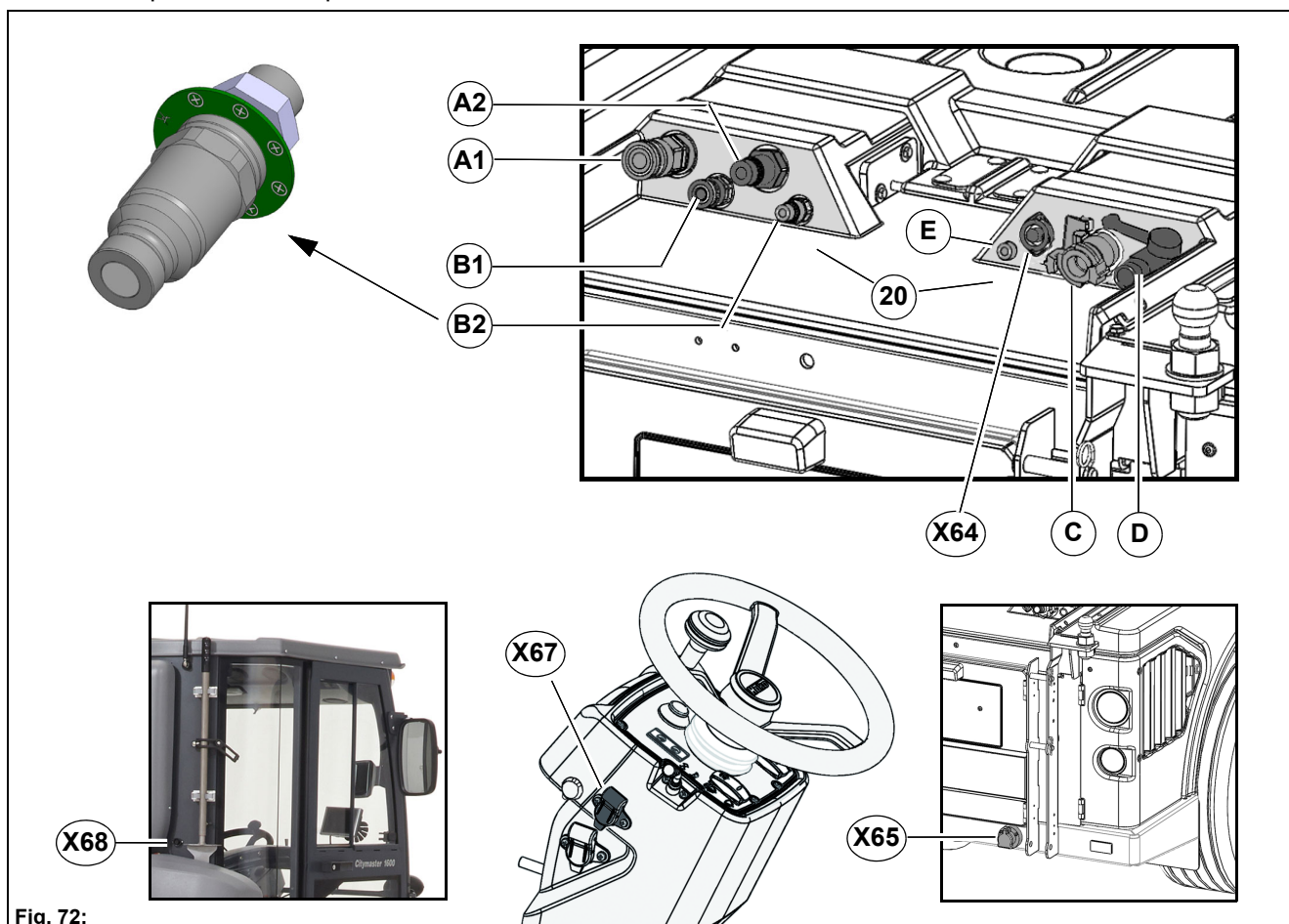


Fig. 72:

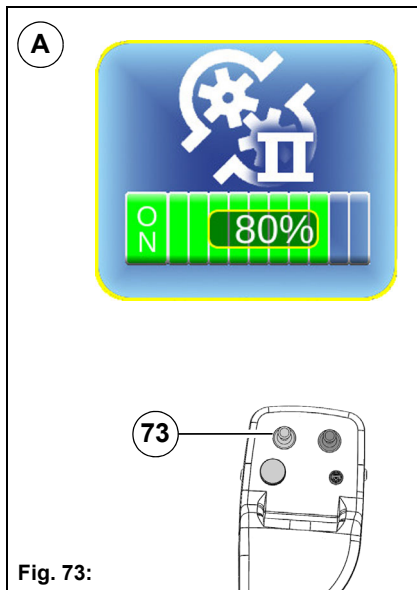


Fig. 73:

Output setting for hydraulic circuit II

The delivery of hydraulic circuit II is in the range between 0 and 32 l/min. In the working menu, hydraulic circuit II **Fig. 71-A** is activated and set to the required value with the turn-push knob **Fig. 73-73**. Setting range: OFF/ON or 0 to 100%

When the vehicle is used with the sweeping unit and the dirt hopper, the power range is set automatically with the coding plugs. The maximum suction power is reached only at standard speed. Operation in the ECO mode ensures noise and consumption-optimised operation of the sweeping machine.

	<p>Danger Risk of injury! Make sure that the attachments are suitable for the set oil volume. An oil volume set too high can lead to injuries due to a defect of the attachment!</p>
--	---

	<p>Note The hydraulic circuit II is switched off if the driver leaves the driver's seat. Restarting by Fig. 73-73 is also possible without the operator on the driver's seat. The driver switches the hydraulic circuit I back on with Fig. 73-73 after returning to the driver's seat. In connection with the sweeping unit and the dirt hopper, hydraulic circuit II remains in operation even when the driver's seat is left (operation of hand suction hose and high-pressure cleaner possible).</p>
--	---

	<p>Note Note that attachments driven on hydraulic circuit II without the presence of the operator at the workplace (driver's seat) can possibly lead to danger to the operator and third parties. Observe the safety instructions and danger warnings for the corresponding attachment. Secure the vehicle by operating the parking brake.</p>
--	---

3 Operation

3.1 Instruction

Instruction is required before the first start-up. The first-time instruction of the Citymaster 1650 may be provided only by a specialist of your authorised Hako dealer.

This person will be notified immediately after delivery of the vehicle from the factory and will contact you to make an instruction appointment.

3.1.1 Climbing up and down



Danger

Risk of injury when getting on and off from slipping, bumping or catching!

If the access area is heavily soiled or smeared with oil, there is risk of slipping. There is a risk of hitting your head at the cab or clothes getting caught when climbing down.

Use the door handle to hold on tight when climbing up and down.

Always climb up forward:

1. Open left-hand door and grip and hold the door handle **Fig. 74-A** with your left hand.
2. Put your left foot in the footwell **Fig. 74-B**.
3. Enter the vehicle with your right foot and sit down on the driver's seat.

Always climb down backwards:

1. Use your left hand to get hold of the door handle and hold on tight.
2. Get up from the driver's seat and exit the vehicle with your right foot first.

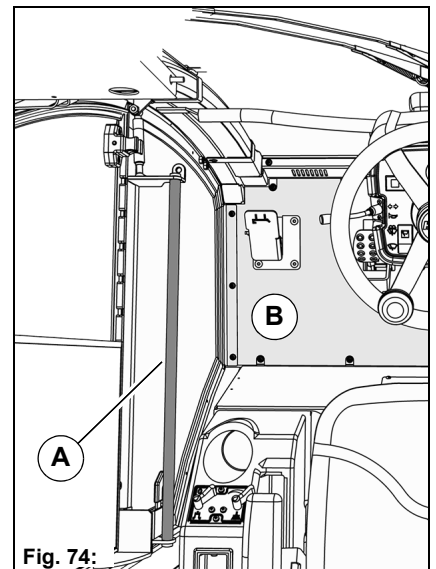





Fig. 74:

3.2 Before start-up of the vehicle


	<p>Danger</p> <ul style="list-style-type: none"> • Risk of accident! If the steering column is unlocked while driving, it can come unexpectedly out of adjustment. You can then lose control over the vehicle. • Risk of accident! Adjust the driver's seat only when the vehicle is stationary. You will otherwise be diverted from the traffic and could lose control over the vehicle by moving the seat. You could cause an accident by this. • Risk of accident! A dirty, damaged seat belt or one stressed or changed in an accident may not offer the intended protection. You could therefore suffer severe injuries or death in an accident. Please check regularly that the seat belts are not damaged and not contaminated. Always have damaged seat belts or those stressed in an accident renewed by an authorised workshop. • Risk of accident! Good viewing conditions contributing to traffic safety are guaranteed only if all windows are free of ice, snow and condensation. Make yourself familiar with the correct operation of the heating and ventilation system as well as de-moisturising/defrosting the windows. Maximum heating power and fast thawing of the windows can be achieved only if the engine has reached its operating temperature. • There is a risk of accidents when driving with open doors! The doors must remain closed when driving on public roads and when working.
	<p>Warning</p> <ul style="list-style-type: none"> • Check the vehicle for its correct condition and operating safety before using it. The vehicle must not be used if it is not in order. • Before starting work, the operator must familiarize himself with all equipment, operating and actuating elements as well as with their function. It is too late to do this during operation! • A warning triangle, a warning light, a warning vest and a first aid kit must be in the vehicle during operation. • Sturdy and slip-proof shoes must be worn when working with the vehicle. • Carrying persons is not permitted! • Only those surfaces approved by the contractor or its authorised representative for use of the vehicle may be driven on. • The vehicle is not suitable for removing dangerous, combustible or explosive liquids, dusts or materials. • Observe the maximum gradability of the vehicle, see Technical data.

3.2.1 Checklist – Before start-up of the vehicle

No.	Description
1	Checking the locking bolt
2	Checking the fuel supply
3	Checking the engine oil level
4	Checking the hydraulic oil level
5	Checking the coolant level
6	Checking the tyre pressure
7	Checking the windscreen washer unit
8	Checking the lighting system
9	Checking the driver's seat and steering column
10	Checking the outside mirrors

	<p>Note Start-up of the vehicle also includes setting the operating data, see page 39.</p>
---	---

Checking the locking bolt

	<p>Danger Danger to life in the danger area of the vehicle! Special caution is required in the area of the articulated steering.</p>
--	---

Before start-up, loosen the locking bolt **Fig. 75-A** on the articulated joint and bring it into the working position. The vehicle cannot be steered with the locking bolt engaged!

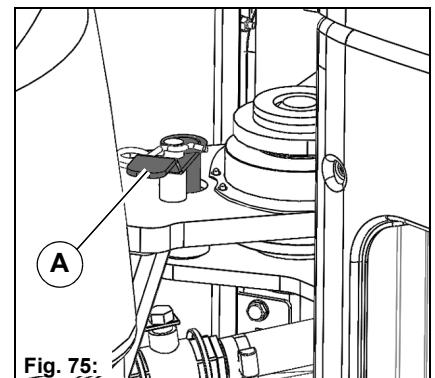
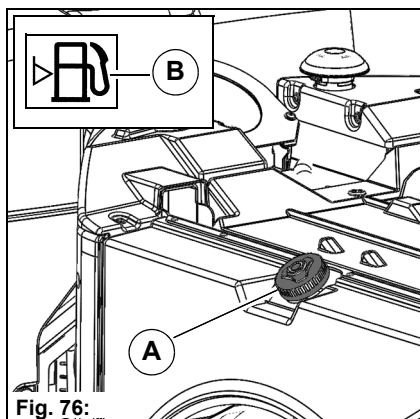


Fig. 75:



Checking the fuel supply



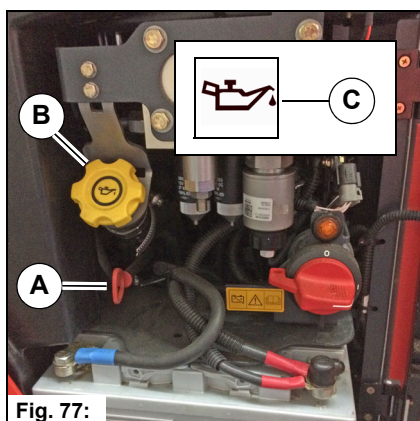
Danger

Risk of fire! Diesel fuel is flammable! Take the utmost care when handling fuel. Never refuel close to naked flames or ignitable sparks. Do not smoke during fuelling. Switch off the engine, pull out the ignition key and engage the parking brake before fuelling.

The current fuel supply is shown in the multifunctional display. Refuel as required.

To do this, open the cap **Fig. 76-A**. Filling volume, see Technical data on page 103.

If the warning symbol **Fig. 76-B** appears, then refuel without delay. There is a risk of engine damage if the fuel system is run completely empty! Inform an authorised workshop!



Checking the engine oil level

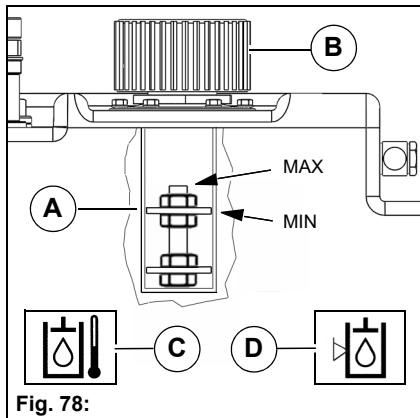


Danger

Caution when handling hot operating and auxiliary materials. There is a risk of burns and scalds!

Check the engine oil level with the dip stick **Fig. 77-A**. Refill with engine oil if required. To do this, open the cap **Fig. 77-B**. Filling volume/Specification, see Technical data on page 103.

If the warning symbol **Fig. 77-C** appears, there is a risk of engine damage. Immediately switch the engine off and check the engine oil level.



Checking the hydraulic oil level




Danger

There is a risk of burns and scalds! Caution when handling hot operating and auxiliary materials.

Check the hydraulic oil level with the level indicator **Fig. 78-A**, if necessary top up hydraulic oil. To do this, open the cap **Fig. 78-B**. Filling volume/Specification, see Technical data on page 103.

If the warning symbol **Fig. 78-C/D** appears, there is a risk of hydraulic system operating failure. Immediately switch the engine off and check the hydraulic oil level.

Checking the coolant level

	<p>Danger Caution when handling hot operating and auxiliary materials. There is a risk of burns and scalds!</p>
---	--

Check the coolant level at the expansion tank **Fig. 79-A**, if necessary top up with coolant. To do this, open the cap **Fig. 79-B**. Filling volume/Specification, see Technical data on page 103.

If the warning symbol **Fig. 79-C** appears, there is a risk of engine damage. Immediately switch the engine off and check the coolant level.

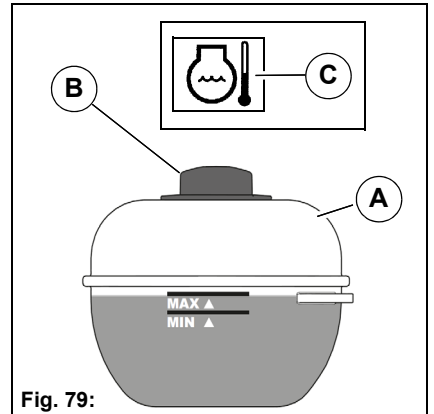


Fig. 79:

Checking the tyre pressure

Remove the valve cap **Fig. 80-A** and adjust the tyre pressure with a compressed air unit, see Technical data on page 103.

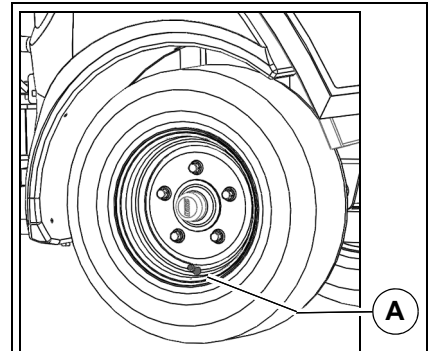


Fig. 80:

Checking the windscreen washer unit

Fill the windscreen washer unit tank **Fig. 81-36**. Filling volume, see Technical data on page 103.

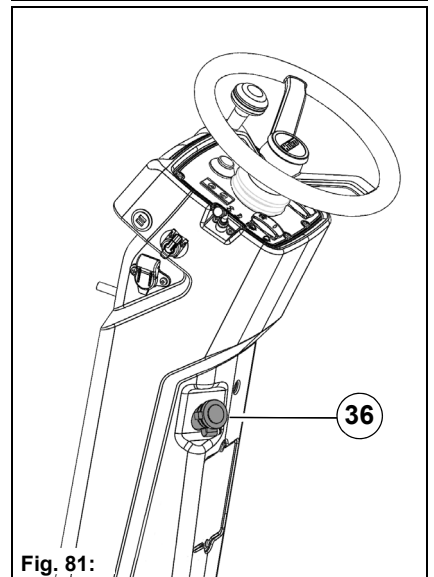


Fig. 81:

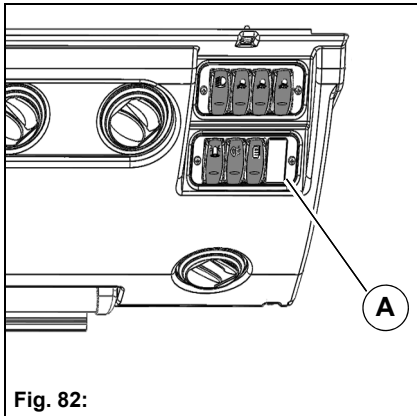


Fig. 82:

Checking the lighting system

Check all lighting equipment on the vehicle with the switches **Fig. 82-A** on the control panel in the roof and the direction indicator in the steering column.

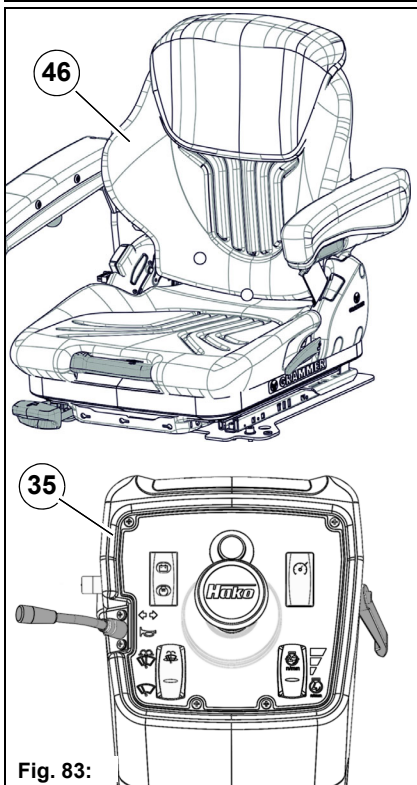


Fig. 83:

Checking the driver's seat and steering column

Adjust the driver's seat **Fig. 83-46** and the steering column **Fig. 83-35** in such a way that all controls can be easily reached.

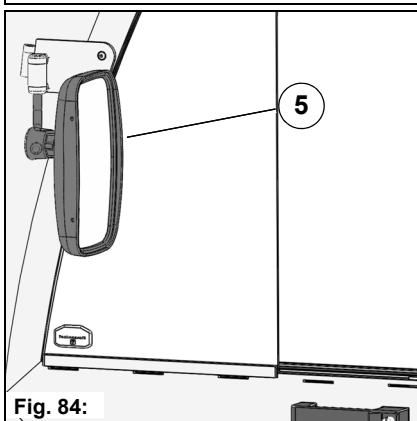


Fig. 84:

Checking the outside mirrors

Adjust the outside mirrors **Fig. 84-5**. Adjust the outside mirrors so that the roadway and the rear work area are completely visible.

3.3 Starting and driving the vehicle



Danger

- Toxic engine exhaust gases! Inhaling exhaust gases is injurious to health and can lead to unconsciousness and to death! Never let the engine run in enclosed spaces.
- Danger to life in the danger area of the vehicle! Special caution is required in the vicinity of the articulated steering, beneath the raised tipper, in the vicinity of the front tool carrier, in the vicinity of the front and rear-mounted equipment and in the area between the vehicle and the trailer.
- Danger of tilting over when driving uphill or downhill and transversely to a slope! Avoid sudden turns when driving uphill or downhill or across slopes. There is a risk of tilting over on slopes of more than 20% with a loaded vehicle! The vehicle speed must always be adapted to the surrounding conditions and the load condition.
- Danger of tilting due to wrong steering! Note that the steering behaviour of an articulated steered vehicle differs essentially from that of a car. Sudden steering movements at high speed or too high speeds when turning can cause the vehicle to tilt over.
- Risk of accident! Note that there is a risk of skidding on unpaved ground or snow and ice. This can lead to uncontrolled behaviour of the vehicle. Drive correspondingly carefully!
- Risk of accident! Use the cruise control and the speed limiter only when the traffic situation allows!
- Risk of accident! Note that dirty pedals can impair the braking effect!
- Risk of accident! When operating at special altitudes (above 3,000 metres), the power of the engine or the engine brake decreases. Adapt your mode of operation and driving style accordingly.

Warning

- For reasons of safety, the vehicle is equipped with a seat contact switch and the function of the seat contact switch must not be bypassed. The vehicle may be started, put into motion and stopped only from the driver's seat. Do not press on the accelerator pedal when starting!
- In the case of restricted vision, especially when reversing the vehicle, it is necessary to have a second person who gives the driver appropriate signals. The second person must always be in the field of view of the driver.
- When working with the vehicle, pay special attention to third persons, especially children.
- In transport journeys on public roads the working lights must be switched off.
- When the engine is still the steering has only emergency steering properties!

Attention

- If the engine oil pressure warning symbol **Fig. 77-A** in the multifunctional display lights up with the engine running, there is a risk of engine damage! Stop the vehicle in the safe range. Turn the engine off immediately and check the oil level. Have the cause of the inadequate engine oil pressure removed.

3.3.1 Starting and driving the vehicle

No.	Description	Reference
1	Accelerator pedal in zero position	Page 88
2	Engaging parking brake	Page 88
3	Starting engine and releasing parking brake	Page 89
4	Starting transport mode	Page 89
5	Activating work mode	Page 90
6	Checking the multifunctional display	Page
7	Setting engine fixed speed for attachments/options	Page 90
8	Activating front tool carrier	Page 90

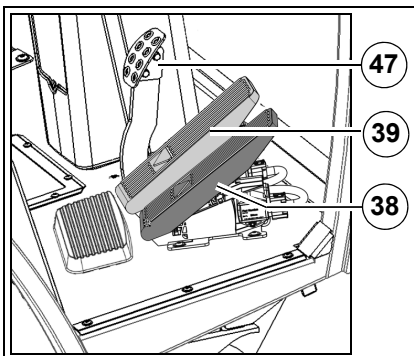


Fig. 85:

Accelerator pedal in zero position

The accelerator pedals **Fig. 85-38** and **Fig. 85-39** must be in the zero position to start the engine.

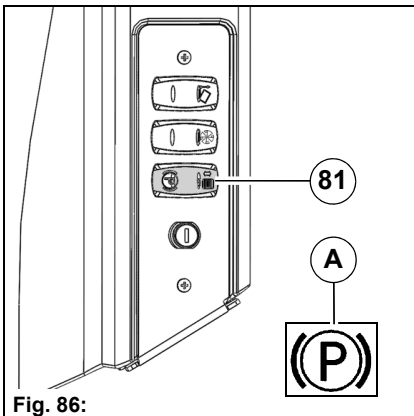



Fig. 86:

Engaging parking brake

The electrical parking brake **Fig. 86-81** stops the vehicle from rolling away.

- Press the brake pedal **Fig. 85-47** until the vehicle stops.
- Unlock the parking brake and press the switch **Fig. 86-81**.
- The warning symbol **Fig. 86-A** appears in the multifunctional display.

Starting the engine

	<p>Note Before starting the engine, depress the brake pedal Fig. 88-47!</p>
---	---

Start the engine with the ignition switch **Fig. 87-82**.

- Position 1: preheat the engine until the control light **Fig. 87-A** goes out.
- Position 2: start the engine.
 - The ignition switch goes back into position 1.

Note the information on the ignition switch on page 65.

Releasing the parking brake

Press the switch **Fig. 87-81**. The parking brake is released again. With the parking brake released the warning light **Fig. 86-A** goes out.

Starting transport mode

Slowly press down the accelerator pedal **Fig. 88-38** or **Fig. 88-39** for the required direction and speed. The vehicle moves away. The corresponding engine speed and the transport mode information symbol **Fig. 88-A** appear in the multifunctional display.

The speed in the transport mode is 0 to 40 km/h.

When the accelerator pedal is released (forwards or reverse) the vehicle comes to a stop quickly because of the hydrostatic braking effect.

In forwards gear up to a speed of approx. 15 km/h the vehicle is in speed level 1. The warning symbol **Fig. 88-B** appears in the multifunctional display.

If the temperature of the hydraulic oil is below 20 °C, the vehicle remains in speed level 1 and the information symbol flashes.

Above a speed of approx. 20 km/h the vehicle is in speed level 2

Fig. 88-C.

This can be delayed depending on the acceleration and the load. In this case the information symbol flashes.

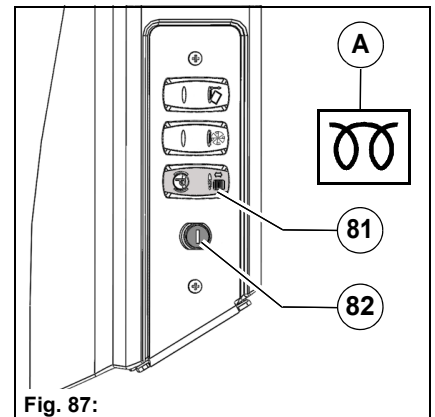


Fig. 87:

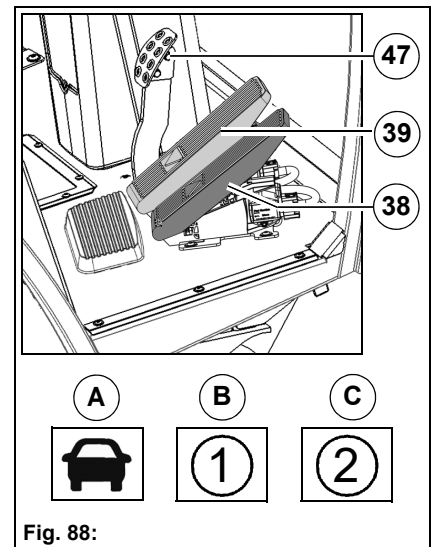


Fig. 88:

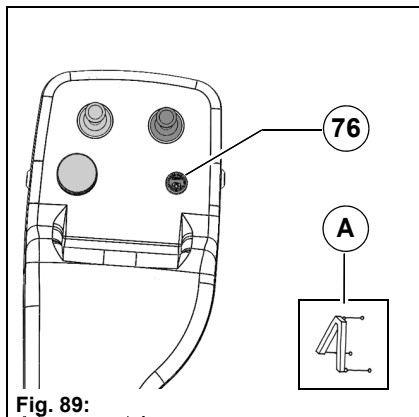


Fig. 89:

Activating work mode

Use the Hako button **Fig. 89-76** to change over from the transport mode to the work mode.

The accelerator pedals must be in the neutral position.

The work mode with front tool carrier information symbol **Fig. 89-A** appears in the multifunctional display.

The road speed in the work mode is maximum 16/20/27 km/h according to the selected engine speed.

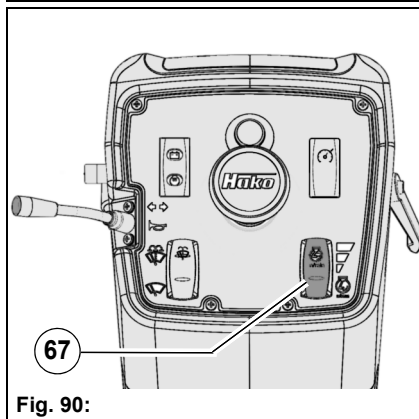


Fig. 90:

Setting the fixed engine speed

The fixed engine speed and thus the system output of the vehicle in the work mode is set with the button **Fig. 90-67**.

Stage	rpm	Hydraulic circuit I litres/minute	Hydraulic circuit II litres/minute
1 - ECO	1600	50	20
2 - Standard	2000	50/70	27
3 - Maximum	2400	50/70	32

The overview illustrates that sufficient power is available already in the ECO mode for many applications.

The full hydraulic output is reached as from the Standard speed.

Additional energy is available in the driving mode as well as in hydraulic circuit II at Maximum. Set the speed according to the requirements. Operation primarily in the ECO mode lowers consumption and noise. See pages 78 and 80 for information about setting the hydraulic circuits.

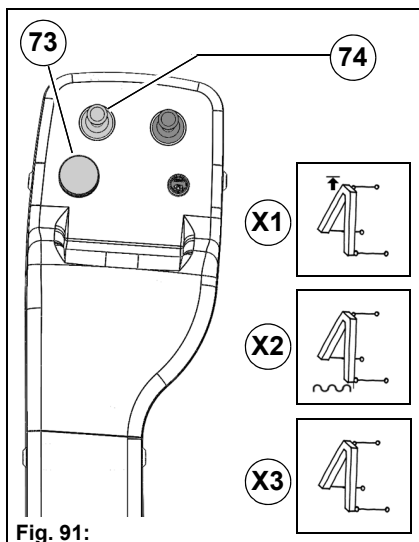


Fig. 91:

Activating the front tool carrier

The front tool carrier is activated with the joystick **Fig. 91-74**. The following functions are possible for a vehicle without attachment:


- Raising front tool carrier
- Front tool carrier in floating position
- Lower the front tool carrier

The position of the front tool carrier is shown in the multifunctional display. Upper end position **Fig. 91-X1** / floating position **Fig. 91-X2** / lowered and fixed **Fig. 91-X3**.

Further settings of the joystick, see page 63.

Raising the front tool carrier is interrupted if the driver leaves the driver's seat.

3.3.2 Diesel particle filter

	<p>Danger</p> <ul style="list-style-type: none"> • Danger of fire and burning! The diesel particulate filter gets very hot. Do not grasp in the area of the diesel particulate filter. Do not park the vehicle in the direct vicinity of flammable substances. <p>Attention</p> <ul style="list-style-type: none"> • If the diesel particulate filter symbol (regeneration requested) Fig. 92-A lights up yellow in the multifunctional display and is ignored, this may cause damage to the diesel particulate filter!
---	--

The vehicle is equipped with a diesel particulate filter. The diesel particulate filter (DPF) filters soot particles from the exhaust gas. During regular regeneration, the accumulated soot particles are burned at high temperatures.

Depending on how high the soot concentration in the diesel particulate filter is, the following modes are provided by the engine control unit:

- Automatic regeneration
- Manual regeneration

Automatic regeneration

The automatic regeneration starts automatically and runs smoothly during work. This mode is used for normal soot concentration. During regeneration, it is warned of hot exhaust gases. The diesel particulate filter (hot exhaust gases) information symbol **Fig. 92-B** appears in the multifunctional display.

If the current situation does not allow it, automatic regeneration can also be disabled. However, the lock should be removed as soon as possible to prevent damage to the diesel particulate filter!

- Use the turn-push knob **Fig. 91-73** to switch from the normal view to the configuration menu and call up the diesel particulate filter setting sub-menu.
- Use the turn-push knob to set the value **Fig. 92-D** to ON. The diesel particulate filter (regeneration locked) information symbol **Fig. 92-C** appears in the multifunctional display.



Fig. 92:

Manual regeneration

The manual regeneration must be started by the operator. This mode is used for increased soot concentration.

The diesel particulate filter (regeneration required) information symbol **Fig. 93-A**. appears in the multifunctional display.

• Use the turn-push knob **Fig. 91-73** to switch from the normal view to the configuration menu and call up the diesel particulate filter menu.

• The following conditions must be fulfilled for regeneration:

- The parking brake has been applied
- The engine is switched on and transport mode has been selected
- Temperature > 10 °C
- Regeneration lock has been switched off

• If all the conditions have been fulfilled, the symbols **Fig. 93-B** light up green. The regeneration can be started. Use the turn-push knob to select the **START** symbol **Fig. 93-C**.

During regeneration, the progress is indicated by a yellow bar. If the exhaust gas temperatures rise, the diesel particulate filter (hot exhaust gases) information symbol **Fig. 93-D** appears. A green bar is displayed once regeneration has been completed.

• Use the turn-push knob to select the **EXIT** symbol and switch back to the normal view.



Note

For uninterrupted manual regeneration, note the following:

- Do not change the speed
- Leave the accelerator pedals in neutral position
- Do not release the parking brake
- Do not use the vehicle during manual regeneration


Non-observance leads to premature termination of regeneration

Fig. 93:

3.3.3 Troubleshooting

The engine does not start, the starter works audibly.	Remedy
The fuel tank was run completely empty.	There is a risk of engine damage if the fuel system is run completely empty! Inform an authorised workshop!
The engine electronics are faulty. The fuel supply is faulty.	Do not repeat the starting procedure more than 3 times, then let the starter cool down. If the engine does not start even after several starting attempts: inform an authorised workshop!
The engine does not start, the starter is not audible.	Remedy
The electrical system voltage is too low because the battery is too weak or empty.	Have starting help applied. If the engine does not start despite starting help: inform an authorised workshop!
The starter was exposed to too high thermal loading.	Let the starter cool down for around 2 minutes. Start the engine again. If the engine still does not start: inform an authorised workshop!
The brake pedal was not depressed.	Depress the brake pedal during the starting procedure!

3.4 Shutting down the vehicle

	<p>Danger</p> <ul style="list-style-type: none">• Risk of accident! Adopt measures against erroneous starting and unwanted movement. Engage the parking brake. Switch the engine off and pull out the ignition key.• Risk of accident! The vehicle must be parked on firm ground. On inclinations secure the vehicle additionally against rolling away with a wheel chock. <p>Attention</p> <ul style="list-style-type: none">• Do not switch the engine off in normal operating condition from the high speed range, only in the case of faults.• After full load operation, let the engine idle on for 1 to 2 minutes.• Do not switch the engine off when an attachment is switched on.• The vehicle is equipped with a diesel particulate filter (DPF). The filter can be very hot after finishing work. Therefore, ensure sufficient distance to combustible materials.
---	---

3.4.1 Shutting down after the end of work

1. Bring the accelerator back into the neutral position or take your foot off from the accelerator pedal. The hydrostatic drive brakes to standstill.
2. Engage the parking brake.
3. Switch the engine off and pull out the ignition key.
4. Close the driver's cab if necessary.

3.4.2 Shutting down in work breaks

The driver must also bring all operating devices into zero position even in short work breaks before leaving the vehicle. Engage the parking brake and secure it against unauthorised use.

3.4.3 Shutting down on occurrence of faults

The engine of the Citymaster 1650 must be switched off immediately on the occurrence of faults. A vehicle left lying on public roads must be secured with the hazard warning system and warning triangle. If the electrical system has failed, the vehicle must be secured with the warning light.

3.5 Transporting and towing the vehicle



Danger

- Danger to life! Start driving slowly! Make sure that there are no persons in the towing area.
- Risk of injury! The vehicle may be loaded only using suitable loading aids, such as a loading ramp or drive-up planks.
- Risk of injury! After loading, make sure that the vehicle is secured according to regulations against rolling off and tilting. Use the wheels for securing the vehicle.

Warning

- Tow the vehicle using only suitable towing gear!
- The vehicle may be towed with a towing rope only if the brakes and steering are functioning!
- When the engine is still the steering has only emergency steering properties!
- When transporting the vehicle, it must be secured against unintentional movements! Engage the parking brake and insert the locking bolt on the articulated joint. Note that the steering is then blocked!

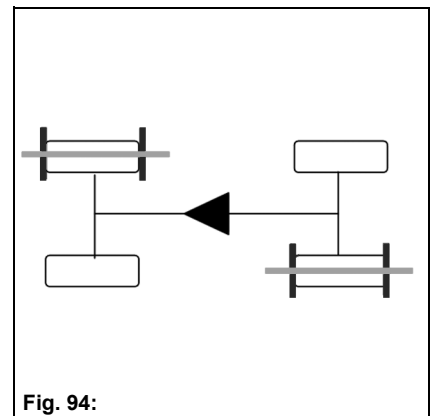
Attention

- The towing speed may be at most 2 km/h, the towing time at most 3 minutes and the towing distance at most 100 m!

3.5.1 Transporting the vehicle

Securing the vehicle:

- Place a wheel chock diagonally before and behind any front or rear wheel.
- Additional security by one three-point belt each.



3.5.2 Towing the vehicle

The wheels are blocked when the vehicle is at a standstill. Proceed as follows for towing or displacing.

1. The towing eye **Fig. 95-A** is located in the rear wagon on the right and must be mounted on the holder **Fig. 95-B** of the front tool carrier **Fig. 95-12**.
2. Turn the lever of the hand pump **Fig. 95-D** into the upper position.
 - upper position = unlock the parking brake
 - lower position = raise/lower the dirt hopper
3. Close the ball cock **Fig. 95-E** to the right of the hand pump (see symbol).
4. Open the ball cock **Fig. 95-F** of the bypass valve (see symbol).
5. Insert the auxiliary tool **Fig. 95-G** in the hand pump **Fig. 95-C** and pump so long (approx. 25 times) until the parking brake is unlocked.



Caution

After completing the towing process, open the ball cock **Fig. 95-E** again and close the ball cock **Fig. 95-F** of the bypass valve again. Set the lever of the hand pump **Fig. 95-C** to the lower position again!

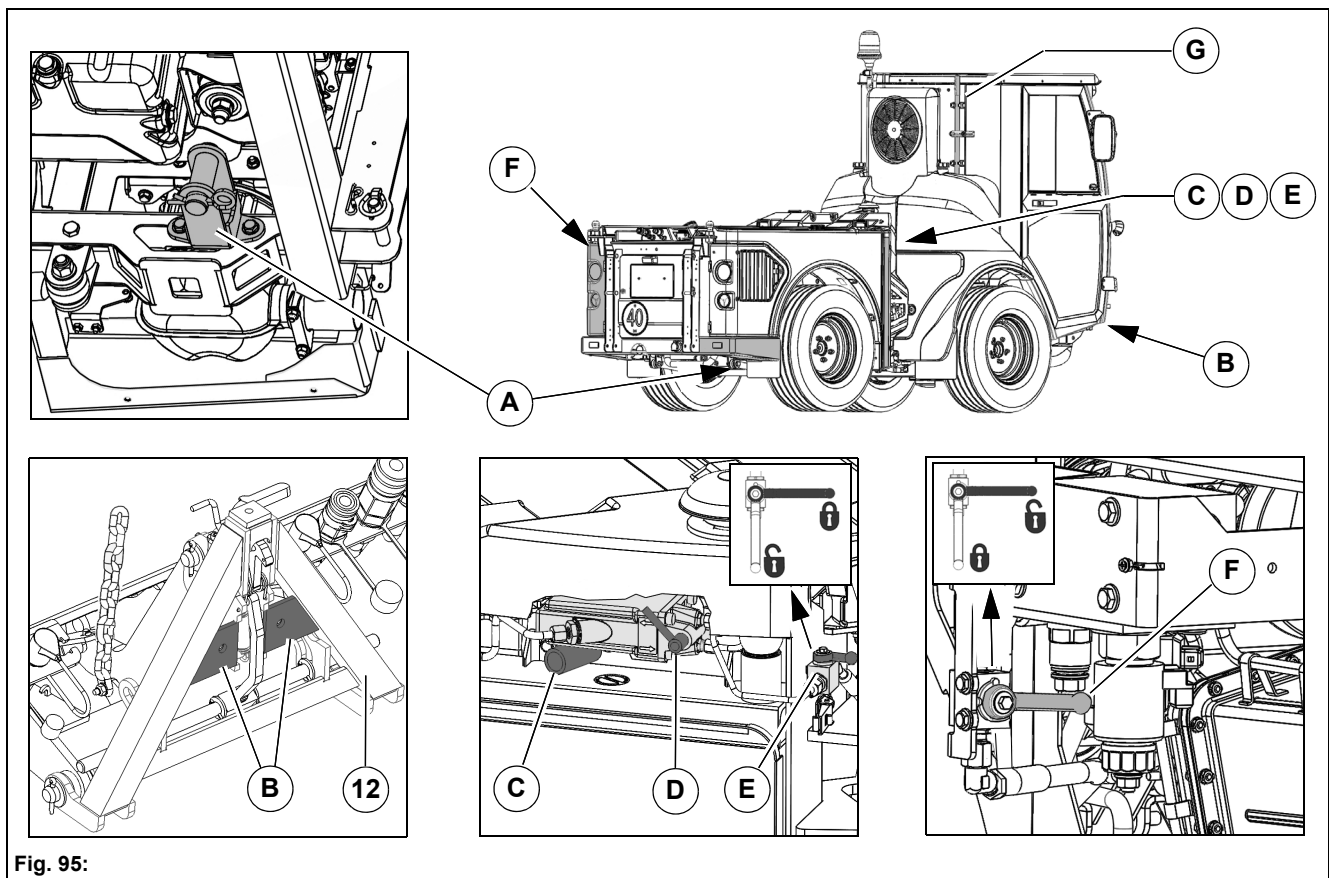


Fig. 95:

3.6 Working with attachments



Danger

- Danger to life in the danger area of the vehicle! Special caution is required in the vicinity of the articulated steering, beneath the raised tipper, in the vicinity of the front tool carrier, in the vicinity of the front and rear-mounted equipment and in the area between the vehicle and the trailer.
- Risk of injury! Put the attachment into service only if all protective devices are attached and in protection position.
- Risk of injury! Make sure that the attachments are suitable for the set oil volume. An oil volume set too high can lead to injuries due to a defect of the attachment!
- Risk of injury! High-pressure hoses, fittings and couplings are important for equipment safety. Use only high-pressure hoses, fittings and couplings recommended by the manufacturer.
- Risk of accident! When connecting attachments to the hydraulic system, ensure that the hydraulic hoses are connected correctly. Swapping the connections can lead to reverse functioning of the attachment, e.g. movement to the right rather than the left.
- Risk of accident! Front attachments not correctly fastened to the front tool carrier can drop down while driving. Always secure the front attachment with the locking devices.
- Risk of accident! You must consult Hako before attaching other attachments not approved by Hako! Check in the individual case that the relevant axial loads and total weights are complied with.
- Risk of accident! Handling, steering and braking as well as stability are influenced by attachments, trailers and the vehicle payload (e.g. full dirt hopper). For this reason, pay attention to adequate steering and braking capability as well as stability.
- Risk of accident! In Germany, if attachments extend beyond the outer lighting equipment of the vehicle or if the maximum distances of the outer lighting equipment specified according to StVZO are exceeded, the lighting equipment of the vehicle must be repeated (see Merkblatt StVZO § 30, explanations 11 and 12).


3.6.1 Hako attachments

You will find the descriptions for the attachment of the vacuum sweeping system, lawn mowing system, sweeping system, snow clearing system and transport system as from page 127.

3.6.2 Non-Hako attachments


You will find the description for the attachment of non-Hako attachments as from page 73.

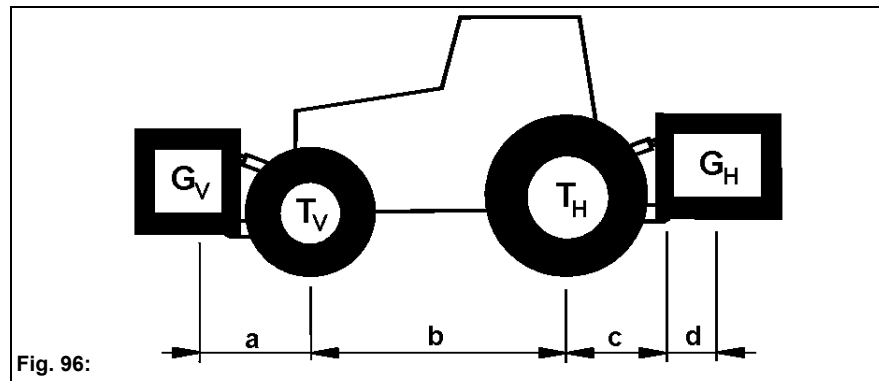
3.6.3 Ballast

	<p>Danger</p> <ul style="list-style-type: none"> • Risk of accident! When attaching other devices not approved by Hako, check in the individual case whether the relevant axle loads and total weights are complied with! • Risk of accident! The front axle of the working machine must always be loaded with at least 25% of the empty weight and the rear axle with at least 37% of the empty weight of the working machine. • Risk of accident! The attachment of front and rear attachments must not lead to exceeding the permissible total weight, the permissible axle load and the tyre load capacity of the working machine! <p>Warning</p> <ul style="list-style-type: none"> • Make sure before purchasing the attachment that these requirements are fulfilled by weighing the working machine attachment combination!
---	---

Calculating ballast

You require the following data to calculate the total weight, the axle loads and the tyre load capacity as well as the required minimum ballast:

	<p>Note</p> <p>All weight data in (kg) All dimensions in (m)</p>
---	---



- 1) See Citymaster 1650 technical data.
- 2) See price list and/or operating manual of the attachment
- 3) Dimensioning

- T_L (kg) = empty weight of the vehicle (1)
- T_V (kg) = front axle load of the empty vehicle (1)
- T_H (kg) = rear axle load of the empty vehicle (1)
- G_H (kg) = total weight of rear attachment/rear ballast (2)
- G_V (kg) = total weight of front attachment/front ballast (2)
- a (m) = distance between centre of gravity of front attachment (front ballast) and middle of front axle max. = 1.75 m (2 and 3)
At maximum front ballast 280 kg.
- b (m) = vehicle wheelbase (1 and 3)
- c (m) = 0.941 m
- d (m) = distance between middle of attachment-side fixing point and centre of gravity of rear attachment/rear ballast max. 0.185 m (2 and 3)
At maximum rear ballast 450 kg.

1 Calculation of the minimum front ballast for rear attachments

$$G_{V \min} = \frac{G_H \times (c+d) - T_V \times b + 0,2 \times T_L \times b}{a+b}$$

Enter the value in the table.

2 Calculation of the minimum rear ballast for front attachments

$$G_{H \min} = \frac{G_V \times a - T_H \times b + x \times T_L \times b}{b+c+d}$$

(Value "x" see manufacturer's data, if no information x = 0.45)

Enter the value in the table.

3 Calculation of the actual front axle load $T_{V \text{tat}}$

If the required minimum front ballast ($G_{V \min}$) is not reached, with the front attachment (G_V), the weight of the front attachment must be increased to the weight of the minimum front ballast!

$$T_{V \text{tat}} = \frac{G_V \times (a+b) + T_V \times b - G_H \times (c+d)}{b}$$

Enter the calculated actual front axle load and the permissible front axle load stated in the operating manual of the work machine in the table.

4 Calculation of the actual total weight

(If the required minimum rear ballast ($G_{H \min}$) is not reached with the rear attachment (G_H), then the weight of the rear attachment must be increased to the weight of the minimum rear ballast!)

$$G_{\text{tat}} = G_V + T_L + G_H$$

Enter the calculated actual total weight and the permissible total weight stated in the operating manual in the table.

5 Calculation of the actual rear axle load

$$T_{H \text{tat}} = G_{\text{tat}} - T_{V \text{tat}}$$

Enter the calculated actual rear axle load and the permissible rear axle load stated in the operating manual of the work machine in the table.

6 Tyre load capacity

Enter double the value (two tyres) of the permissible tyre load capacity (see for example documents of the tyre manufacturer) in the table.

Ballast table

The calculated values must be less than or equal to the permissible values!

	Actual value according to calculation		Permissible value according to operating manual		
Front/rear minimum ballast	kg	≤			
Total weight	kg		kg		
Front axle load	kg	≤	kg	≤	kg
Rear axle load	kg	≤	kg	≤	kg

The minimum ballast must be attached to the vehicle as attachment or ballast weight!

Mounting the ballast weight

The following accessories are available for ballast:

Accessory	Type
Front weight holder for max. 9 ballast weights	344000
Rear weight holder for max. 10 ballast weights	344130
Ballast weight 17 kg	343900

Fit a sufficient number of ballast weights **Fig. 97-C** to the weight holder **Fig. 97-A** or **Fig. 97-B** and secure with retaining bolts and split pins.

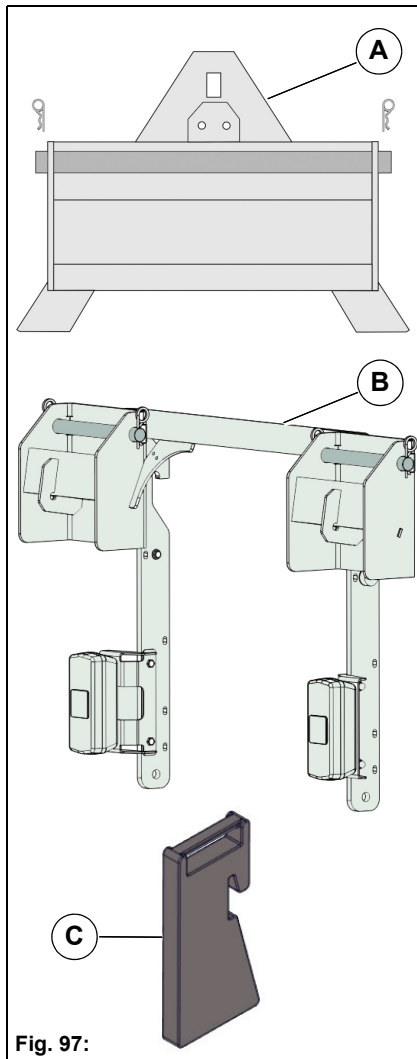


Fig. 97:

4 Technical Data

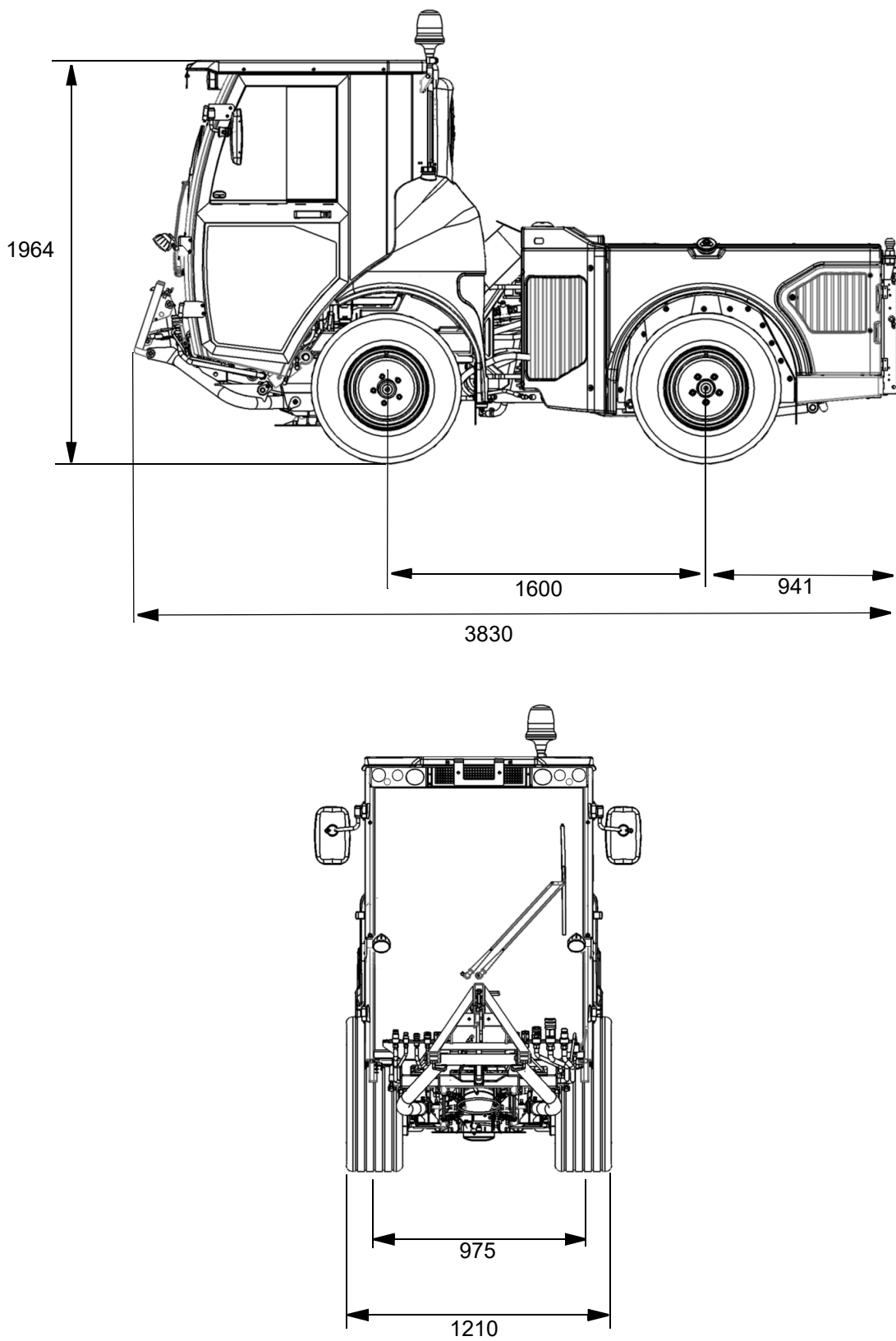


Fig. 98:

Technical Data

Dimensions

Name	Unit	
Length	mm	3830
Width (with standard tyres)	mm	1210
Height (with standard tyres)	mm	1970
Wheelbase	mm	1600
Tread width (with standard tyres)	mm	975
Turning circle inside/outside (DIN EN 15429-1)	mm	2580/5520

Weights and loads

Name	Unit	
Empty weight (deviations according to equipment)	kg	2035-2570
Permissible total weight	kg	3500
Permissible total combination weight unbraked	kg	4250
Permissible total combination weight braked	kg	5250
Permissible front axle load	kg	1700
Permissible rear axle load	kg	2400

Driving speeds and inclination values

Name	Unit	
Transport mode/work mode forwards	km/h	0-40/0-27
Transport mode/work mode reverse	km/h	0-12
Gradability basic vehicle in work mode (forwards/reverse)	%	24
Gradability basic vehicle in transport mode (forwards/reverse)	%	24

Noise emission values – basic vehicle

Driving noise according to regulation (EU) 2018/985 Annex II:	80 dB(A)
Standing noise according to regulation (EU) 2018/985 Annex. II at 2400 rpm:	75 dB(A)
Noise at driver's ear according to regulation (EU) 1322/2014 Annex. 13 at 2400 rpm (closed window/open window):	75/76 dB(A)

Vibration values – basic vehicle

The weighted effective value of the acceleration to which the body (feet or seat surface) is subjected to according to EN 1032 is under the customary conditions of use no more than:	0.5 m/s ²
---	----------------------

Engine

Manufacturer		Hatz KG
Type		4H50TIC
Number of cylinders		4
Displacement	cm ³	1952
Power	kW	55.0/2800
Speed	rpm	2800
Torque	Nm	240/2000
Engine oil filling volume Engine oil: Fuchs Titan CARGO 5W-40; Fuchs Titan CARGO 10W-40 or equivalent Specification: ACEA E9, API CK-4	litre	7.0
Coolant filling volume Coolant specification: VW G13 or equivalent, e.g.: Total Glacelf Auto Supra	litre	12.5

Fuel system

Tank volume	litre	52
Fuel specification: Diesel (EN 590)		

Hydraulic system

Tank volume	litre	45
Hydraulic oil specification: HVLP 46, e.g.: Mobiloil DTE 10 Excel		
Lifting power of front tool carrier with clearance = 0 mm/600 mm	N	6000/3500

Tyres

Standard tyres 225/70 R15C	Tyre inflation pressure 5.0 bar	Load-bearing capacity 1200 kg
Optional tyres 255/65 R16C (Goodyear Wrangler HP ALL Weather/Goodyear Wrangler UltraGrip/FalkenWildpeak AT01/Continental CrossCon- tact Winter/ Maxis MA SW Wintermaxx/Fulda Tramp 4x4)	Tyre inflation pressure 3.0 bar	Load-bearing capacity 1200 kg
285/65 R16C (Continental Vanco Four Season M&S/Goodyear Cargo Vector)	3.2 bar	1200 kg
320/55-15 (T559 Turf Grip)	2.8 bar	1090 kg

Pay attention to the installation inflation pressure when fitting the tyres! This may be a maximum of 1.5 times the tyre inflation pressure.

Electrical system

Starter	kW	2.0
Nominal voltage	Volt	12
Generator	Ampere	140

Windscreen washer unit

Tank volume	litre	2.0
-------------	-------	-----

5 Maintenance and Servicing

General



Attention

Before undertaking servicing and maintenance work, read and observe the safety instructions in chapter 1 of this operating manual!

Compliance with the maintenance work recommended by us gives you the certainty of always having an operational vehicle available.

Daily and weekly maintenance work can be done by the operating staff. In all other maintenance work, see service booklet, please contact your nearest authorised Hako dealer.

Any warranty claim is null and void if this is not complied with and damage results.

Please always state the serial number in all enquiries and spare parts orders, see the Labels on the vehicle section.

5.1 Maintenance plan


Work to be performed by the customer by reference to the maintenance and servicing instructions specified in the operating manual.

Hako system maintenance customer

Daily
<p>Vehicle cleaning</p> <ul style="list-style-type: none"> • Vehicle cleaning as required
<p>Engine</p> <ul style="list-style-type: none"> • Checking engine oil level, replenishing if necessary • Checking and if necessary refilling coolant level in expansion tank • Checking combination radiator and radiator grille for dirt, cleaning with compressed air if necessary • Checking fuel supply, refuelling if required • Checking air filter, cleaning or replacing filter element if necessary
<p>Steering</p> <ul style="list-style-type: none"> • Checking the emergency steering function
<p>Brake</p> <ul style="list-style-type: none"> • Checking the operating and parking brakes for function
<p>Electrical system</p> <ul style="list-style-type: none"> • Checking lighting, work functions, horn, etc.

Weekly
<p>Vehicle cleaning</p> <ul style="list-style-type: none"> • Vehicle cleaning as required
<p>Engine</p> <ul style="list-style-type: none"> • Checking engine oil level, replenishing if necessary • Checking and if necessary refilling coolant level in expansion tank • Checking combination radiator and radiator grille for dirt, cleaning with compressed air if necessary • Checking fuel supply, refuelling if required • Checking air filter, cleaning or replacing filter element if necessary • Emptying the water trap of the fuel system
<p>Cab</p> <ul style="list-style-type: none"> • Checking the windscreen washing agent level, refilling if necessary • Checking air conditioning system for function • Checking heating for function
<p>Steering</p> <ul style="list-style-type: none"> • Checking the emergency steering function • Checking steering cylinder for play
<p>Brake</p> <ul style="list-style-type: none"> • Checking the operating and parking brakes for function • Braking test
<p>Hydraulics</p> <ul style="list-style-type: none"> • Checking the hydraulic oil level, refilling if necessary
<p>Lubrication service (see section 5.11)</p> <ul style="list-style-type: none"> • Door hinges (4x) • Front lifting cylinder (4x), front lift (2x) and upper link (2x) • Steering cylinder (4x)
<p>Tyres</p> <ul style="list-style-type: none"> • Checking the air pressure of the tyres

5.2 Panelling and covers

	<p>Danger</p> <ul style="list-style-type: none">• Risk of injury! Put the vehicle into service only if all protective devices are attached and in protection position.• Danger of burning! Do not touch any parts such as engine block, cooling system and exhaust system during operation and for some time after.
---	---

5.2.1 Opening the engine cover, engine flap and side door

The engine cover **Fig. 99-A**, the engine flap **Fig. 99-B** and the side doors **Fig. 99-C** are opened with a square key.

5.2.2 Removing side paneling

Loosen the mounting screws of the side paneling **Fig. 99-D** and pull the side paneling out to the side.

5.2.3 Opening the radiator cover

Open the lock **Fig. 99-E** and swing down the radiator cover.

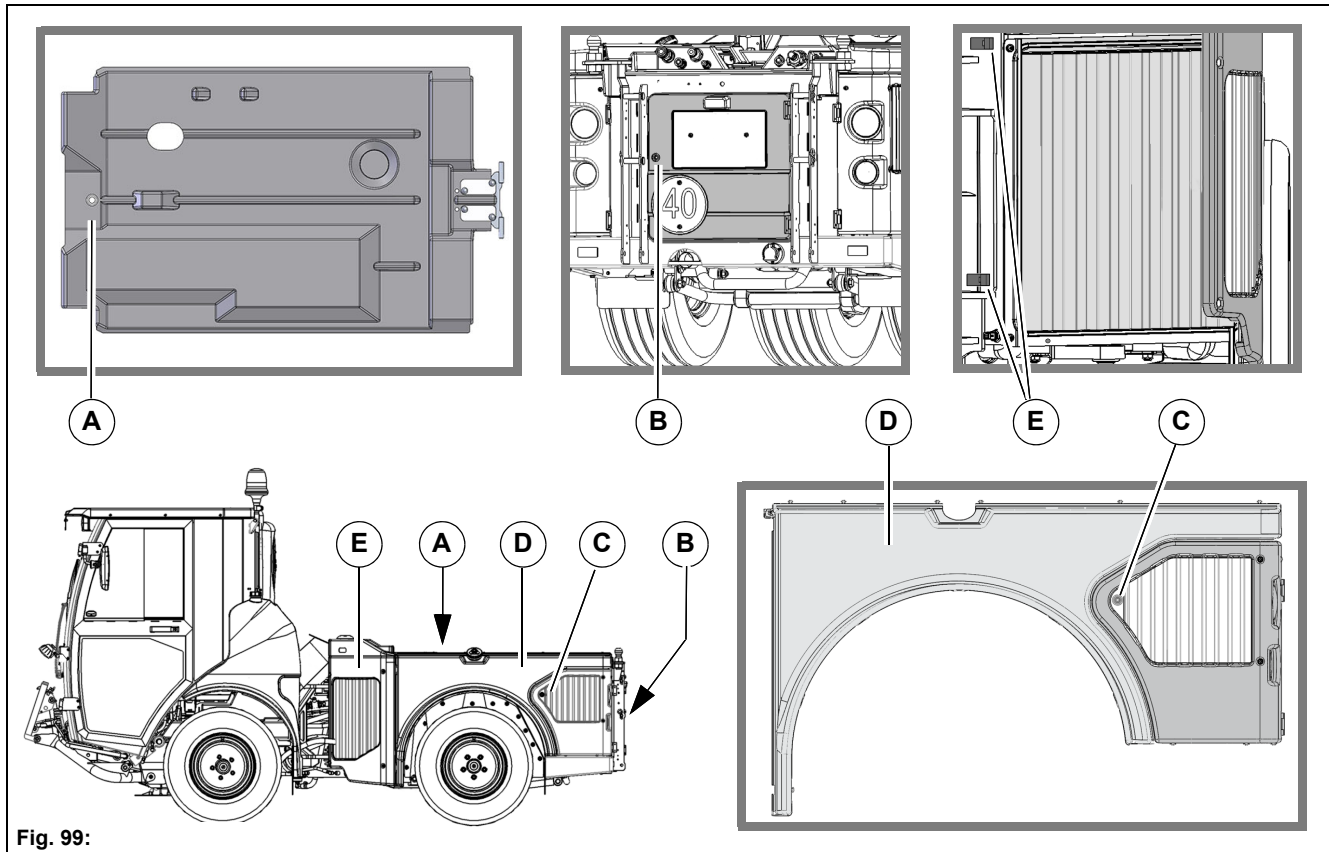


Fig. 99:

5.3 Engine



Danger

- Toxic engine exhaust gases! Inhaling exhaust gases is injurious to health and can lead to unconsciousness and to death! Never let the engine run in enclosed spaces.
- Danger of burns from hot parts! Do not touch any parts such as engine block, cooling system and exhaust system during operation and for some time after. Let the engine cool down.
- Risk of scalding from hot engine oil! If the cap is opened when the engine is hot, there is a risk of scalding. Let the engine cool down.
- Risk of injury due to rotating parts! Injury of limbs or hair or clothing getting caught up. Switch the engine off and pull out the ignition key.

Attention

- If the engine oil pressure warning symbol **Fig. 100-A** appears in the multifunctional display with the engine running, there is a risk of engine damage! Stop the vehicle in the safe range. Turn the engine off immediately and check the oil level. Have the cause of the inadequate engine oil pressure removed.

Environmental danger

- Ensure safe and environment-conserving disposal of operating and auxiliary materials. Take up escaping or spilled operating materials in suitable containers and dispose of them in an environmentally friendly manner.

5.3.1 Checking the engine oil level

Check the engine oil level daily and refill as required.

1. Place the vehicle on a level surface and hold it with the parking brake. Switch the engine off and pull out the ignition key. Let the engine cool down.



Note

The circulating engine oil requires a few minutes to flow back to the oil sump.

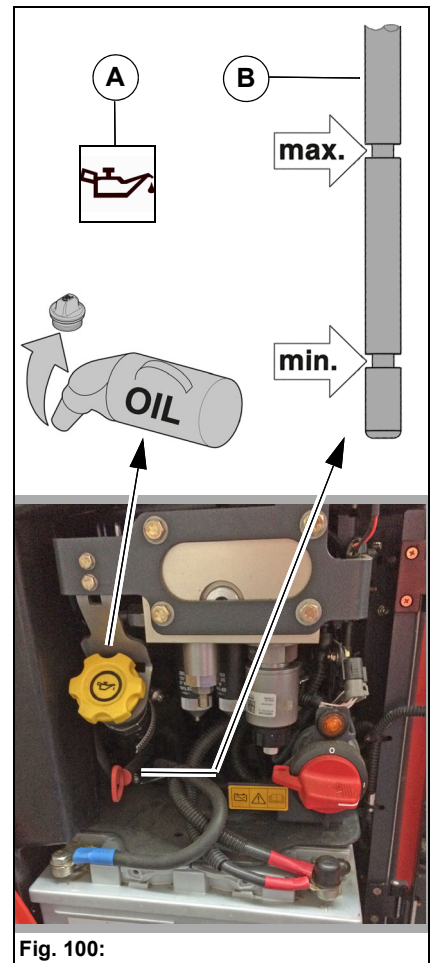
2. Check the engine oil level with the dip stick **Fig. 100-B**.
3. The engine oil level should lie between the MAX and MIN mark of the dip stick and may never drop below the MIN mark.
4. Refill engine oil as required and check the engine oil level once again. Filling volume/Specification, see Technical data on page 103.




Note

Engine operation with an oil level below the min. mark or above the max. mark can lead to engine damage.

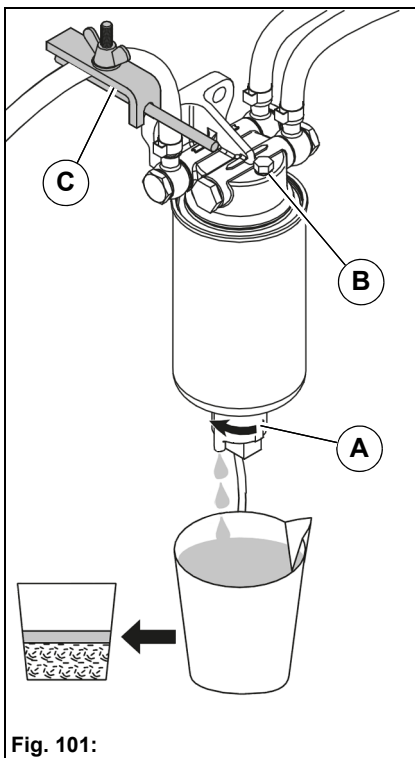
5. Reinsert the dip stick.



5.4 Fuel system

	<p>Danger</p> <ul style="list-style-type: none"> • Risk of fire! Diesel fuel is flammable! Take the utmost care when handling fuel. Never refuel close to naked flames or ignitable sparks. Do not smoke during fuelling. Switch off the engine, pull out the ignition key and engage the parking brake before fuelling. • Danger of burns from hot parts! Do not touch any parts such as engine block, cooling system and exhaust system during operation and for some time after. Let the engine cool down. <p>Attention</p> <ul style="list-style-type: none"> • If the fuel system has been run empty, the vehicle must be stopped immediately. Serious engine damage can be caused if this is not complied with. The fuel system must be vented. Have this done by an authorised workshop! <p>Environmental danger</p> <ul style="list-style-type: none"> • Ensure safe and environment-conserving disposal of operating and auxiliary materials. Take up escaping or spilled operating materials in suitable containers and dispose of them in an environmentally friendly manner.
---	---

5.4.1 Emptying the water trap



Emptying the water trap

Check the water trap weekly and drain the condensed water out from the water trap if required.

1. Place the vehicle on a level surface and hold it with the parking brake. Switch the engine off and pull out the ignition key. Let the engine cool down.
2. Place a suitable container under the outlet of the drain screw **Fig. 101-A**. Note: in the event of restricted access, an extension hose can be connected to the outlet on the drain screw.
3. Open the drain screw and drain the water into the container.
4. If not enough liquid escapes, additionally loosen the vent screw **Fig. 101-B**. Note: if the fuel tank is lower than the fuel pre-filter, the fuel feed line must be pinched off with a hose clamp **Fig. 101-C**. Otherwise, fuel will flow back into the tank after opening the drain screw.
5. As soon as fuel escapes, close the drain screw and vent screw. Note: water escapes first and then fuel. This can be seen by a clear dividing line.
6. Release the fuel feed line if necessary, dispose of the water/fuel mixture in an environmentally friendly way.

5.5 Cooling system



Danger

- Danger of burns from hot parts! Do not touch any parts such as engine block, cooling system and exhaust system during operation and for some time after. Let the engine cool down.
- Risk of scalding from hot coolant! The cooling system is under pressure. If the cooling system cap is opened with a hot engine there is a risk of scalding. Let the engine cool down.
- Risk of injury due to rotating parts! Injury of limbs or hair or clothing getting caught up. Switch the engine off and pull out the ignition key.

Attention

- Small air bubbles can form when the radiator is filled. Therefore the cooling system must be vented at the same time. Have this done by an authorised workshop!
- The cooling fins are very thin and can be damaged easily!

Environmental danger

- Ensure safe and environment-conserving disposal of operating and auxiliary materials. Take up escaping or spilled operating materials in suitable containers and dispose of them in an environmentally friendly manner.

5.5.1 Cleaning the cooling system

Check the grille screen **Fig. 102-A** and the cooling fins of the combination cooler located behind **Fig. 102-B** and of the hydraulic oil cooler **Fig. 102-C** daily and clean as required.

1. Place the vehicle on a level surface and hold it with the parking brake. Switch the engine off and pull out the ignition key. Let the engine cool down.
2. Open the lock **Fig. 102-D** (see sketch) and swing down the radiator cover **Fig. 102-E**.
3. Check the grille screen and the cooling fins of the combination cooler located behind daily and clean with compressed air or water jet as required.

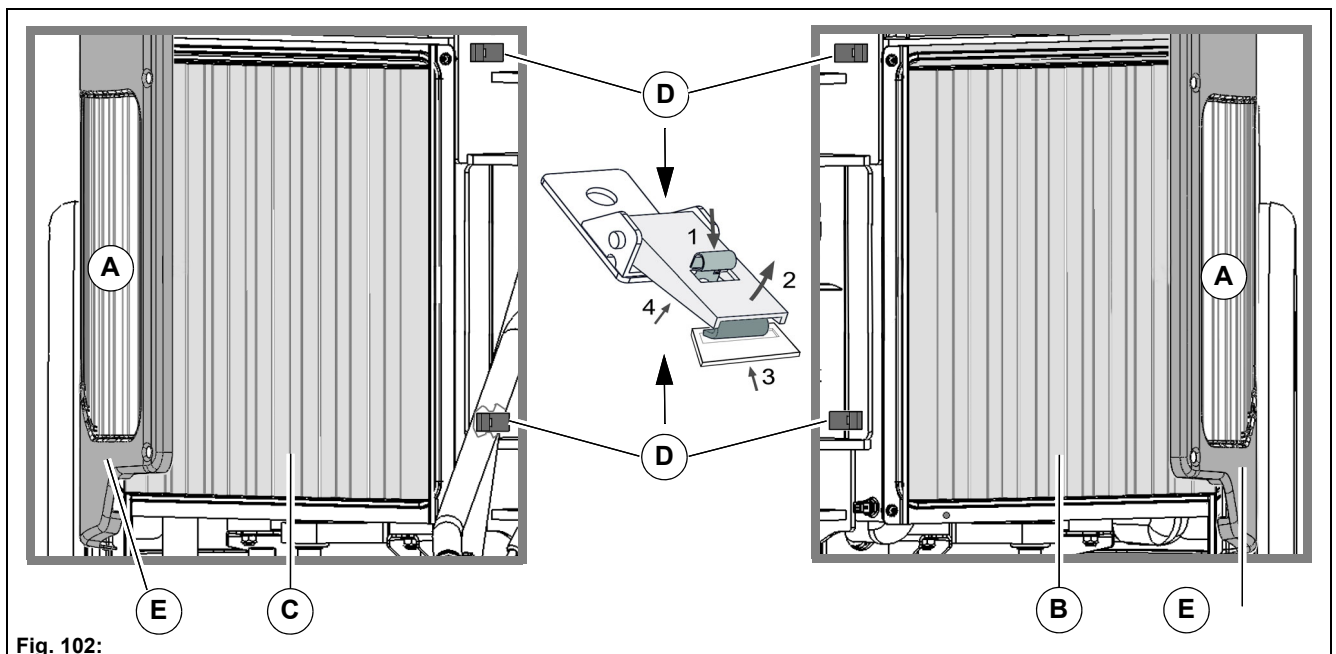


Fig. 102:

5.5.2 Checking the coolant level

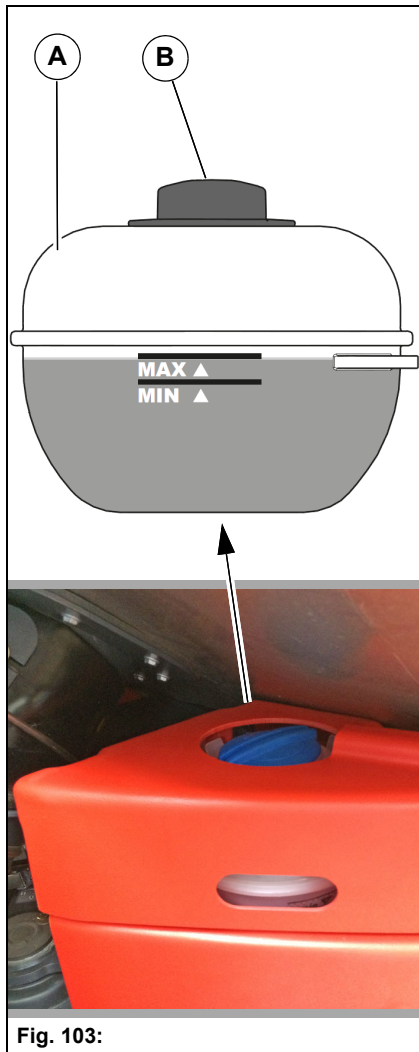


Fig. 103:

Check the coolant level in the expansion tank **Fig. 103-A** daily and refill as required.

1. Place the vehicle on a level surface and hold it with the parking brake. Switch the engine off and pull out the ignition key. Let the engine cool down.
2. Check the coolant level.
With the engine cooled down, the coolant must be visible between the MIN and MAX mark of the expansion tank.
Engine operation with a coolant level below the MIN mark can lead to engine damage.
3. Unscrew the cap **Fig. 103-B** carefully step by step from the expansion tank.
4. Refill coolant:
The coolant must be prepared according to the manufacturer's instructions before being filled into the cooling circuit. Please observe the packaging imprint.
Filling volume/Specification, see Technical data on page 103.

	<p>Attention The coolant additive must be at least 40% and may be a maximum of 50%. Exceeding or falling below the coolant concentration can lead to serious engine damage!</p>
--	--

Coolant additive	Water	Frost resistant up to approx.
min. 40% by volume	60% by volume	-27 °C
max. 50% by volume	50% by volume	-38 °C

5. Check the coolant level, refill once again if necessary.
6. Close the cap again.

5.6 Air filter



Warning

- Danger of burns from hot parts! Do not touch any parts such as engine block, cooling system and exhaust system during operation and for some time after. Let the engine cool down.

Attention

- We can assume no liability for cleaned filter inserts. Never let the engine run without a filter insert!
- Only replace the safety cartridge, do not clean it! Never let the engine run without safety cartridge!

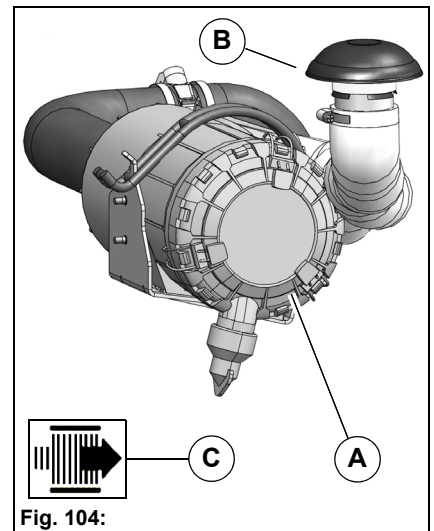
Environmental danger

- Ensure safe and environment-conserving disposal of operating and auxiliary materials. Take up escaping or spilled operating materials in suitable containers and dispose of them in an environmentally friendly manner.

5.6.1 Checking the air filter

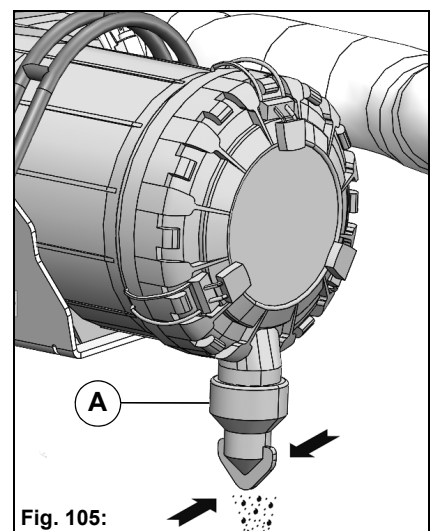
Check the contamination of the air filter **Fig. 104-A** daily. Check the suction opening **Fig. 104-B** for heavy contamination such as leaves, heavy dust accumulation, etc. and clean if necessary.

If the air filter is contaminated, the air filter symbol **Fig. 104-C** appears in the multifunctional display.




5.6.2 Cyclone separator and dust ejection valve

The air filter has a cyclone separator incorporated in the filter housing. This lengthens considerably the service life of the filter insert. The dust particles separated in the filter housing are ejected from the dust ejection valve **Fig. 105-A**. Check the dust ejection valve for free flow. Remove dust caps by pressing them together.



5.7 Hydraulic system

	Danger
	<ul style="list-style-type: none">• Risk of injury from hydraulic oil! Hydraulic oil issuing under high pressure can penetrate the skin and cause severe injuries. Therefore, even with the smallest wounds, consult a doctor since otherwise severe infections can arise!• Danger of burns from hot parts! Do not touch any parts such as engine block, cooling system and exhaust system during operation and for some time after. Let the engine cool down.
	Warning
	<ul style="list-style-type: none">• Do not touch any parts such as engine block, cooling system and exhaust system during operation and for some time after – risk of burns!• Work on the hydraulic system of the vehicle may be done only by persons with special knowledge and experience in hydraulics.• Regularly check all pipes, hoses and screw connections for leaks and external visible damage. Immediately rectify damage and leaks. Oil squirting out can cause injuries and fires. Observe the recommended replacement intervals for hydraulic pipes. Replace hydraulic hose lines every five years from the date of manufacture, even if they do not seem to be damaged!• Hydraulic hose lines must always be attached in the correct location! Fittings and the length and quality of the hose line must comply with the requirements.
	Environmental danger
	<ul style="list-style-type: none">• Ensure safe and environment-conserving disposal of operating and auxiliary materials. Take up escaping or spilled operating materials in suitable containers and dispose of them in an environmentally friendly manner.

Safety instructions – Hydraulic hose lines

For more information, please see:

- Latest version of DGUV rule 113-020 "Hydraulic hoses and hydraulic fluids - rules for safe use"
- DIN 20066 T5

Identification of hydraulic hose lines

Regardless of the flexible line, each hydraulic hose line is permanently marked with at least the following information on the press sleeve:

- manufacturer's name or identification, e.g. XXX,
- operating pressure (maximum working pressure) of hydraulic hose line, e.g. 330 bar,
- The last two digits of the year of manufacture and the month of manufacture, e.g. 1910 for October 2019.

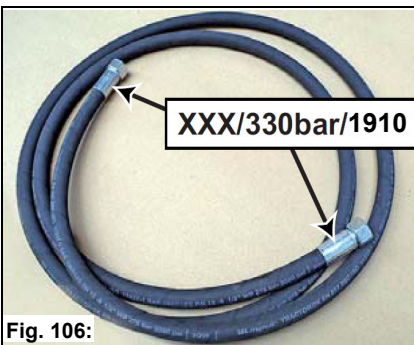


Fig. 106:

5.7.1 Important information for using BIO OIL


**Attention**

- Use only the BIO hydraulic fluids approved by the Hako GmbH, see Operating materials and lubricants. Use of another not recommended products must be agreed with Hako without fail. In addition, a written guarantee declaration must be obtained from the supplier. This guarantee applies for the case that damage to hydraulic units occurs that is demonstrably attributable to the hydraulic fluid.
- Use only BIO oil of the same grade for topping up and oil changing. Clear information about the momentary oil grade used must be placed close to the filler cap! Mixing two BIO oil grades can impair the properties of one grade. Make sure that when the BIO oil is changed, the remaining residual volume of the original hydraulic fluid in the hydraulic system does not exceed 8% (manufacturer's data).
- Do not top up with mineral oil. The mineral oil content should not exceed 2% by weight to avoid foaming problems and not to impair the biological degradability of the BIO oil.
- The same oil and filter changing intervals apply for operation with BIO oils as for mineral oils, see Operating materials and lubricants. The condensed water in the hydraulic oil tank must be drained off before the cold season. The water content should not exceed 0.1% by weight.
- All information about environmental protection in this operating manual also applies when BIO oils are used.
- If additional hydraulic devices are attached and operated, then operate these with the same BIO oil grades, so that mixing in the hydraulic system is avoided.
- In subsequent oil changing from mineral to BIO oil, the hydraulic units must be scavenged completely.

5.7.2 Checking the hydraulic oil level

Check the hydraulic oil level weekly at the level indicator **Fig. 107-A** and top up as required.

1. Place the vehicle on a level surface and hold it with the parking brake. Switch the engine off and pull out the ignition key. Let the engine cool down.
2. Unscrew the cap **Fig. 107-B** and top up with hydraulic oil. Filling volume/Specification, see Technical data on page 103.
3. The hydraulic oil level should lie between the MIN and MAX mark.
4. Refit the cap.

	<p>Note</p> <p>The specification of the grade of hydraulic oil added in the factory can be found on an adhesive plate in the vehicle cab. Always use the identical oil for topping up. Mixing different hydraulic oils is not permitted. This would reduce the efficiency and reliability of your machine. Hydraulic components could be damaged. If all of the hydraulic oil is replaced, the usual procedures must be noted (e.g. flush several times, maximum residual hydraulic oil content: 2%). Note the name of the new hydraulic oil on the existing adhesive plate with a permanent marker. If the vehicle is used under different climatic conditions than when the initial filling took place (e.g. HVLP 46 for central European conditions), hydraulic oil with a different viscosity class must be used.</p>
---	--

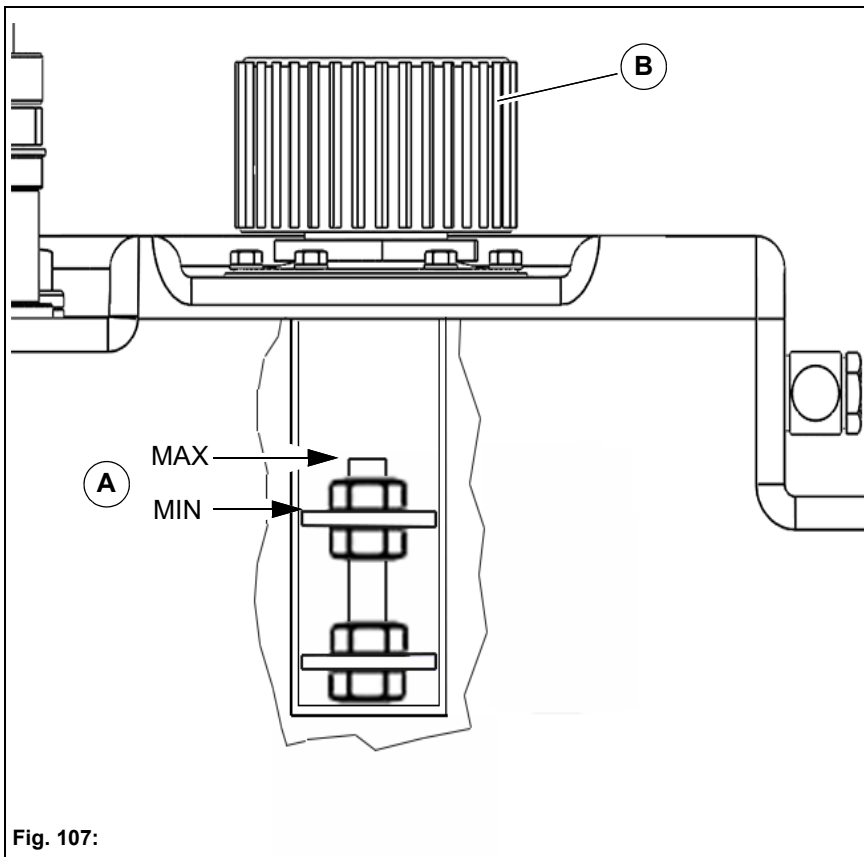


Fig. 107:

5.8 Driver's cab

5.8.1 Changing the cab air filter

Check the cab air filter weekly for contamination, more frequently in dusty work. Remove it as follows:

1. Place the vehicle on a level surface and hold it with the parking brake. Switch the engine off and pull out the ignition key.
2. Loosen the four mounting screws of the protective grille **Fig. 108-A** and remove the protective grille.
3. Remove and clean the cab air filter **Fig. 108-B** and renew it if necessary.

Summer operation

Insert the perforated plate **Fig. 108-C** located behind the cab air filter so that the mark points to the "S".

Winter operation

Insert the perforated plate located behind the cab air filter so that the mark points to the "W".

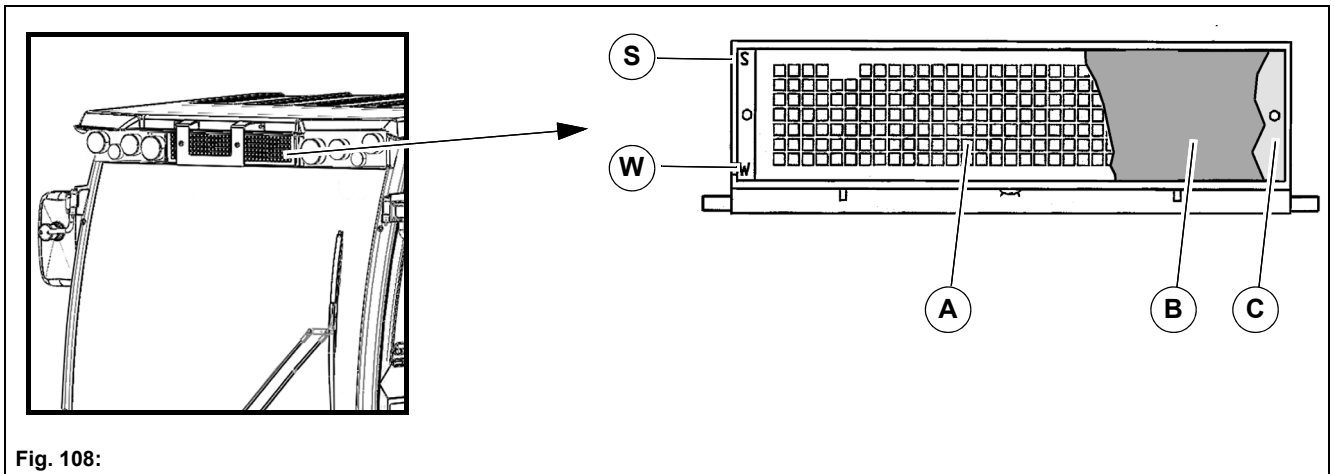


Fig. 108:

5.9 Wheels



Warning

- Risk of accident! Repair work on tyres and rims may be undertaken only by skilled personnel or authorised workshops.
- Use only tyres approved by Hako, see Technical data on page 103.
- When changing wheels, make sure that the jack is applied to the specified jacking point!
- Damaged tyres and/or incorrect tyre pressure reduce the operating safety of the vehicle. There is a risk of an accident with tyres with too low or too high tyre pressure!
- Check the wheel nuts regularly for firm seating. After a tyre change check the wheel nuts after 50 km and tighten them if necessary.

5.9.1 Tyre changing

Dismantling

1. Place the vehicle on a level surface and hold it with the parking brake. Switch the engine off and pull out the ignition key. Let the engine cool down.
2. Fit jack to jacking points on a secure footing:
Front wheel left/right: **Fig. 109-A**, see symbol
Rear of vehicle left/right: **Fig. 109-B**, see symbol
3. Raise the corresponding axle side and check the vehicle once again for stability.
4. Remove the wheel bolts and remove the wheel.

Mounting

1. Fit the wheel on the centring hub and tighten all wheel bolts slightly.
2. Jack the raised axle side down.
3. Tighten the wheel bolts crosswise with a torque wrench. The necessary tightening torque is: 180 Nm.
4. The wheel bolts must be tightened again as described above after approx. 50 operating hours.

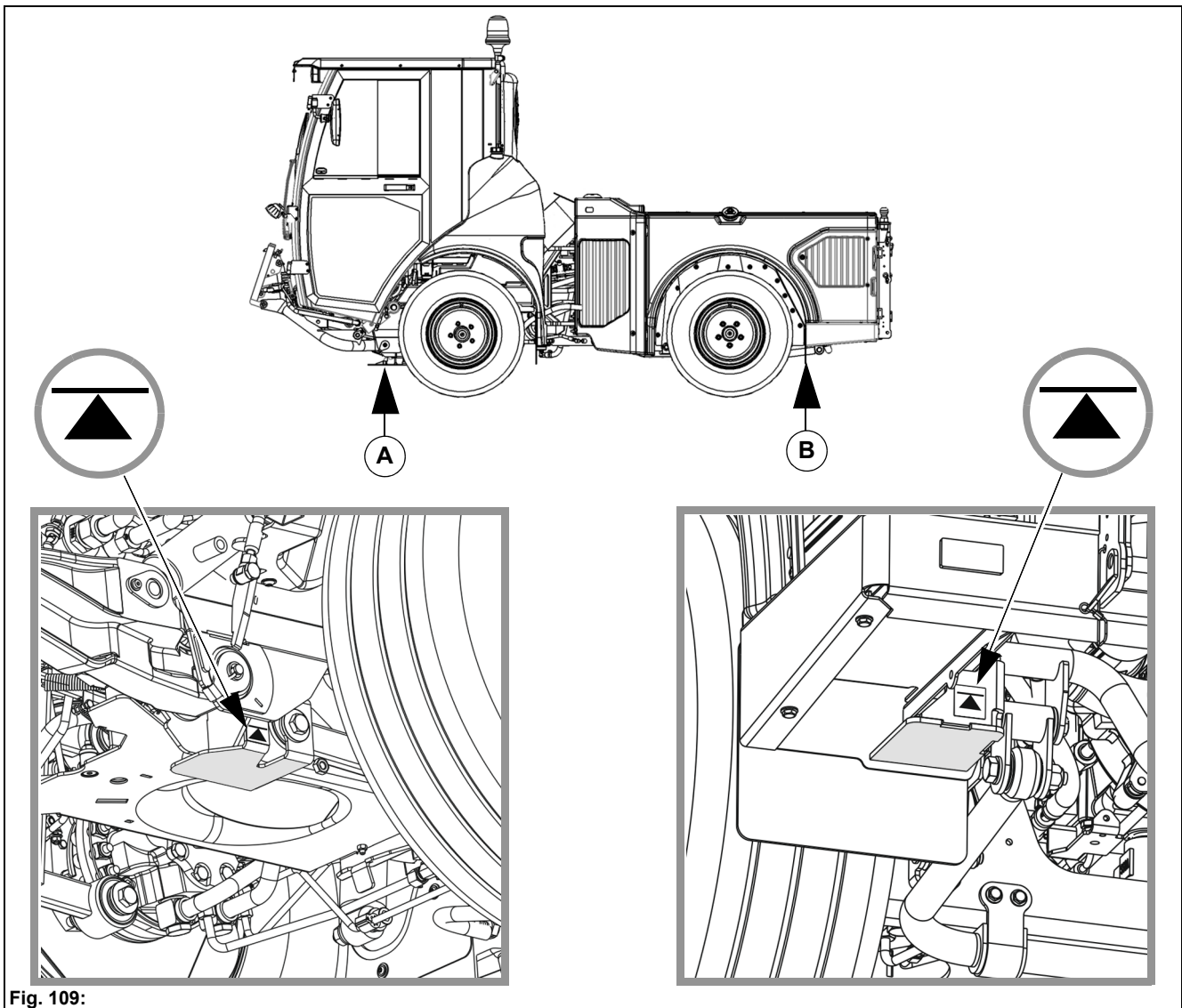


Fig. 109:

5.10 Electrical system

5.10.1 Lamps

Standard lighting	Figure	Electrical value
Dipped headlight	Fig. 110-A	12 V - 55 W
Front direction indicator	Fig. 110-B	12 V - 21 W (yellow)
Parking light	Fig. 110-C	12 V - 5 W
Direction indicator for brake lights and rear light	Fig. 110-D	LED
Number plate light	Fig. 110-E	LED
Reversing light (optional) (optionally right or left)	Fig. 110-F	LED
Rear fog light (optional) (optionally right or left)	Fig. 110-G	LED
Interior light	Fig. 110-H	12 V - 5 W
Front work area working light	Fig. 110-I	LED

Rotating beacon (optional)	Figure	Electrical value
Standard rotating beacon (optionally)	Fig. 110-J	12 V - 55 W
LED rotating beacon (optionally)	Fig. 110-K	LED



Fig. 110:

LED lighting	Figure	Electrical value
LED lighting (optionally for basic lighting)		
Dipped head light	Fig. 111-A	LED
Front direction indicator	Fig. 111-B	LED
Parking light	Fig. 111-C	LED
Direction indicator for brake light and rear light	Fig. 111-D	LED
Number plate light	Fig. 111-E	LED
Reversing light (optionally right or left)	Fig. 111-F	LED
Rear fog light (optionally right or left)	Fig. 111-G	LED
Interior light	Fig. 111-H	LED

Working light (optional)	Figure	Electrical value
Suction mouth working light	Fig. 111-I	LED
Rear cab working light	Fig. 111-J	LED
Top cab working light	Fig. 111-K	LED

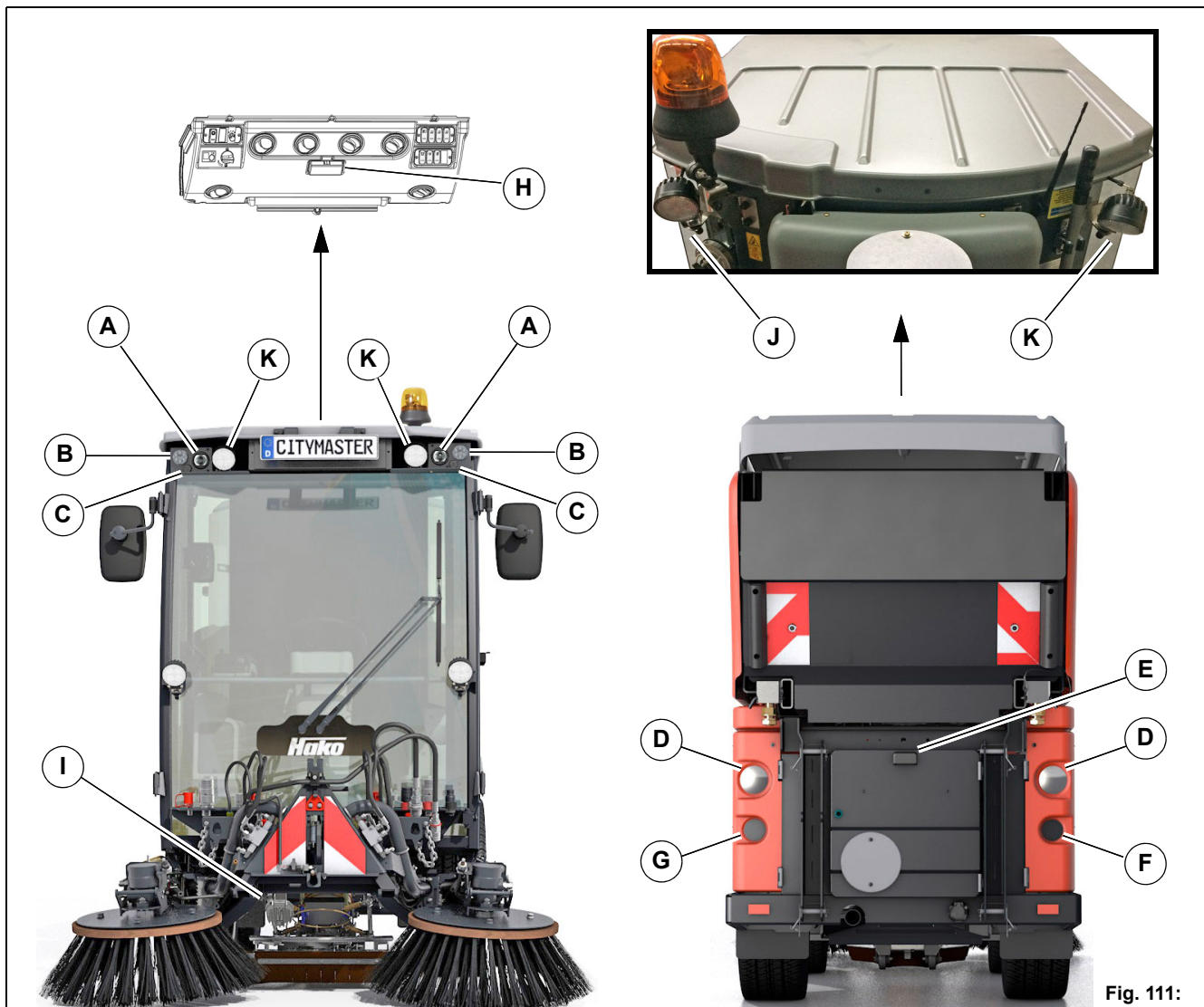


Fig. 111:

5.10.2 Fuses and relays

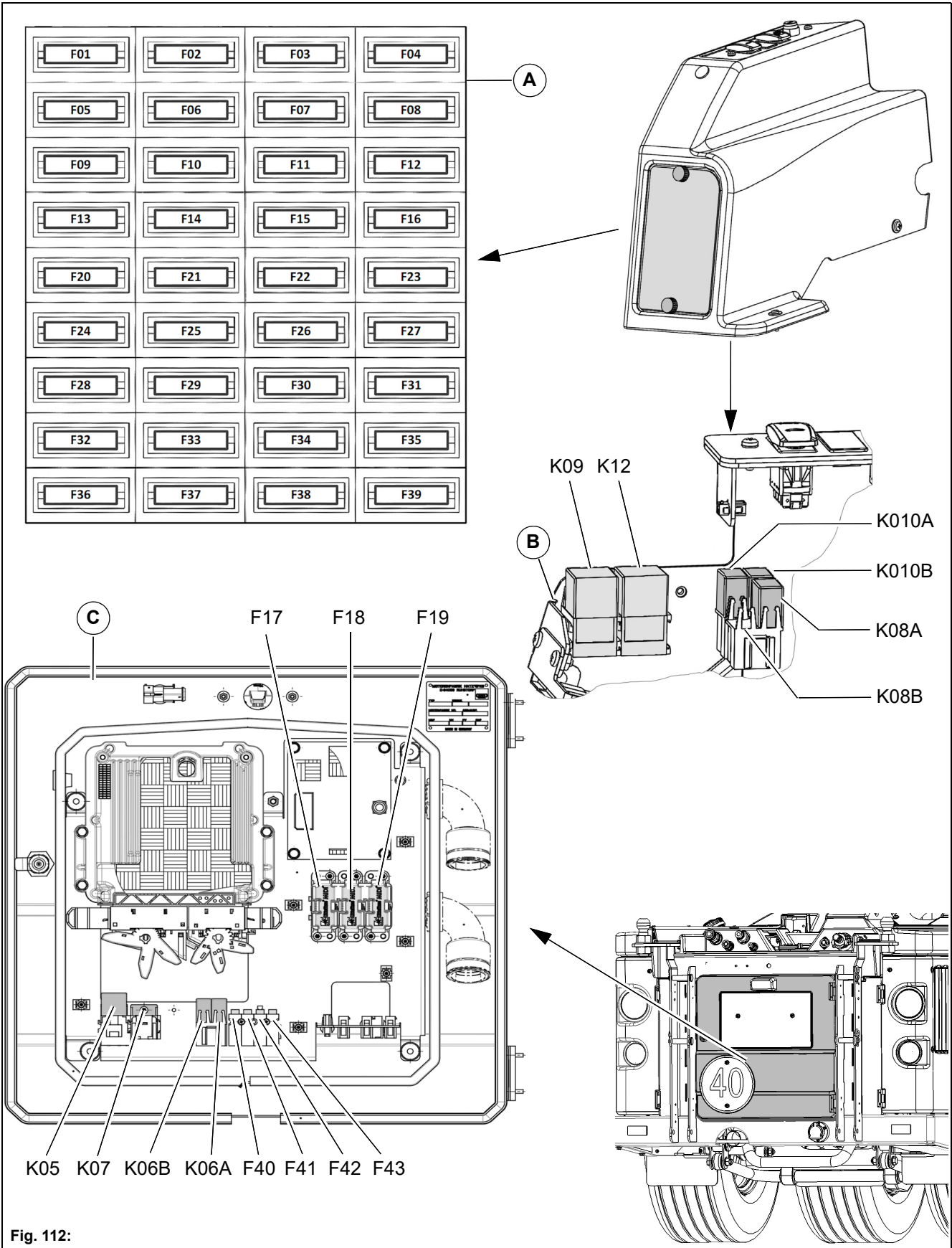


Fig. 112:

No.:	Value	Function
		Right-hand control panel Fig. 112-A:
F01	20 A	Air conditioning system and mirror heating
F02	15 A	Heating suction fan
F03	20 A	Hydraulic control unit
F04	10 A	Video* and radio* plug
F05	5 A	Engine control unit, hydraulic control unit, mirror heating
F06	10 A	Drive control unit, hydraulic control unit and suction mouth
F07	15 A	Spray water pump (for brush units)
F08	15 A	Hydraulic control unit and rear socket (X64)
F09	10 A	Windscreen wiper, windscreen washer pump and hydraulic control unit
F10	15 A	Heating/Air conditioning system
F11	15 A	A-pillar* working light
F12	15 A	Main front headlight and rear fog light*
F13	10 A	Rotating beacon* and interior light
F14	15 A	Blinker/Warning light
F15	7.5 A	Rear light (terminal 58L) and position light (terminal 57L)
F16	7.5 A	Rear light (terminal 58R) and position light (terminal 57R)
F20	7.5 A	Starter
F21	15 A	Hydraulics and horn
F22	5 A	Drive control unit, hydraulic control unit, 3-brush system* control unit, independent vehicle heater*
F23	15 A	Pre-fuse (F15, F16 and F35)
F24	5 A	USB socket
F25	10 A	Rear cab* working light and suction mouth* working light
F26	15 A	Radio*
F27	15 A	3-pin steering column socket (X61)
F28	10 A	Driver's seat
F29	5 A	Fleet-Recorder*, 12-pin steering column socket (X67)
F30	10 A	Brake light
F31	5 A	Fleet-Recorder*, 12-pin steering column socket (X67)
F32		Not used
F33		Not used
F34		Not used
F35		Not used

* Optional

No.:	Value	Function
Continuation – right-hand control panel Fig. 112-A:		
F36	5 A	Spare fuse
F37	7.5 A	Spare fuse
F38	10 A	Spare fuse
F39	15 A	Spare fuse
Right-hand control panel Fig. 112-B:		
K08A		Windscreen wiper
K08B		Rear fog light*
K09		Air conditioning system
K10A		Relief relay terminal 15
K10B		Voltage and proportional valves
K12		Independent vehicle heater* suction fan activation
Electrical box Fig. 112-C:		
F17	50 A	Main fuse for: F08- F12, F25, F28 and F30, terminal 58 (F13, F23 and F24)
F18	50 A	Main fuse: terminal 30 (F01- F03, F14, F21-F22, F26, F31-F33) and terminal 15 (F04-F07, F27, F29 and F34), F42 and F43
F19	50 A	Main fuse for: Engine control unit, F40 and F41
F40	15 A	Sweeping unit 3-brush system* control unit
F41	15 A	Sweeping unit 3-brush system* control unit
F42	30 A	Drive control unit
F43	20 A	Independent vehicle heater*
K05		Supply terminal 75
K06A		Starter release
K06B		Brake light
K07		Sweeping unit 3-brush system*
Comfort steering column (optional) Fig. 113-A:		
K11A		Windscreen washer pump

* Optional

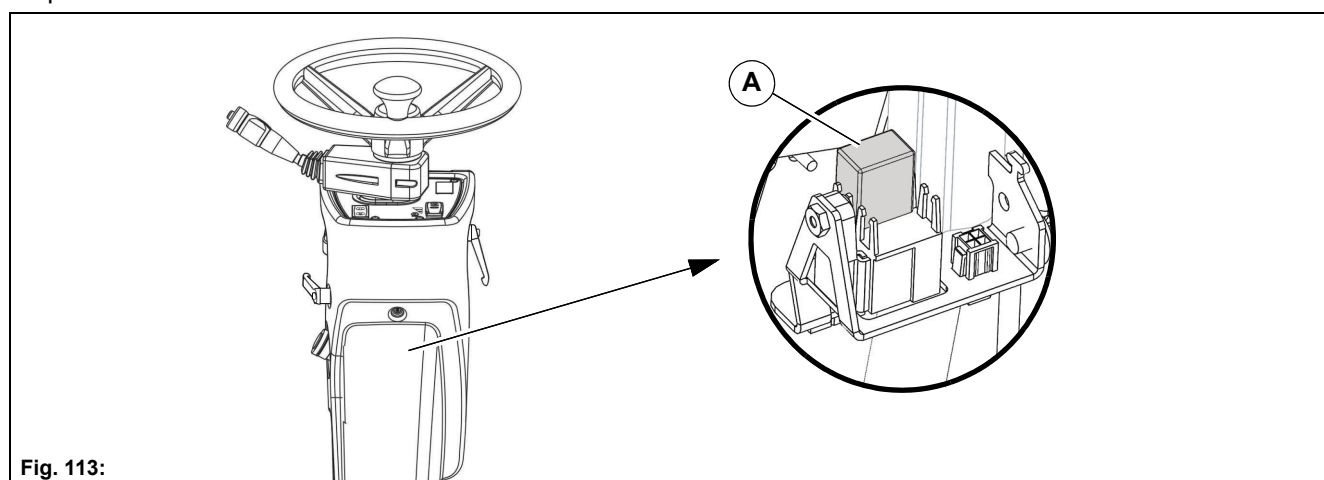

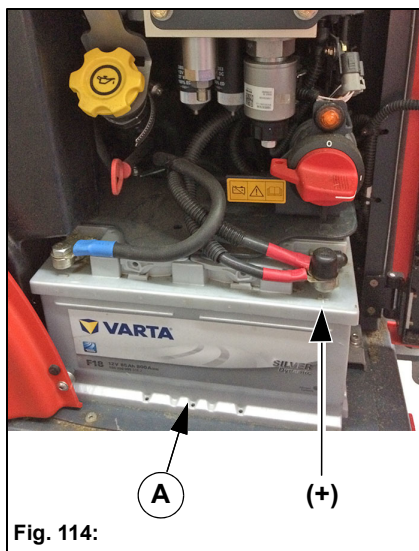


Fig. 113:

5.10.3 Battery

	<p>Danger</p> <ul style="list-style-type: none">• Danger of explosion due to smoking, fire or open light! Especially when being charged, but also in the normal use of batteries, batteries emit explosive gases! Avoid smoking, fire, sparks or open light in the vicinity of batteries!• Danger of explosion due to sparks! Never place tools or other electrically conductive objects on the battery! Sparks that can ignite escaping gases arise if the poles are short-circuited. Always observe the correct order when connecting and disconnecting the battery!<ul style="list-style-type: none">• Disconnecting the battery: first the minus pole and then the plus pole!• Connecting the battery: first the plus pole and then the minus pole!• Danger of explosion due to frozen battery or too low acid level! With a frozen battery or if the acid level is too low, do not attempt to start with a jumper cable, the battery can burst or explode.• Danger of burns due to battery acid! The special safety and accident prevention regulations must be complied with when handling the battery. Batteries contain sulphuric acid.
---	--



Removing the battery

1. Place the vehicle on a level surface and hold it with the parking brake. Switch the engine off and pull out the ignition key. Let the engine cool down.
2. If present, switch the battery isolating switch off and remove the key.
3. Open the left side door and loosen the battery holder of the battery **Fig. 114-A**.
4. Disconnecting the battery: first the minus pole and then the plus pole!
5. Remove the battery. Clean and grease the battery poles.
6. Recharge the battery or replace it by a new battery of the same strength.
7. Connecting the battery: first the plus pole and then the minus pole!

Starting with jumper cables

1. Place the vehicle on a level surface and hold it with the parking brake. Switch the engine off and pull out the ignition key. Let the engine cool down.
2. Switch engine and electrical consumers of both vehicles off.
3. Connect the plus cable (red) with one end to the plus pole (+) of the empty battery and with the other end to the plus pole (+) of the assisting vehicle.
4. Connect the minus cable (black) to the minus pole (-) of the supporting vehicle and to the minus pole (-) of the Citymaster 1650.
5. Start the engine of the assisting vehicle.
6. Start the Citymaster 1650.
7. When removing the jumper cable, first remove the minus poles (-) and then the plus poles (+).

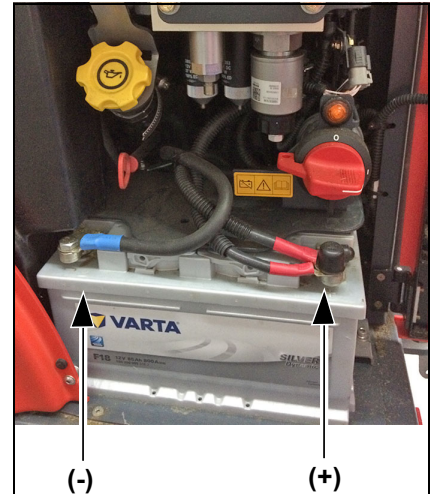


Fig. 115:

Battery isolating switch (optional)

The battery isolation switch **Fig. 116-A** is behind the left side door. If the vehicle is parked for a longer period of time, the battery may self-discharge. For this case:

1. Switch off the vehicle with the ignition switch. The indicator light **Fig. 116-B** goes off after about 30 seconds.
2. Turn battery isolation switch to the left (vertical). The battery is disconnected from the on-board power supply.



Attention

The battery isolation switch may not be switched off if the indicator light **Fig. 116-B** is on!

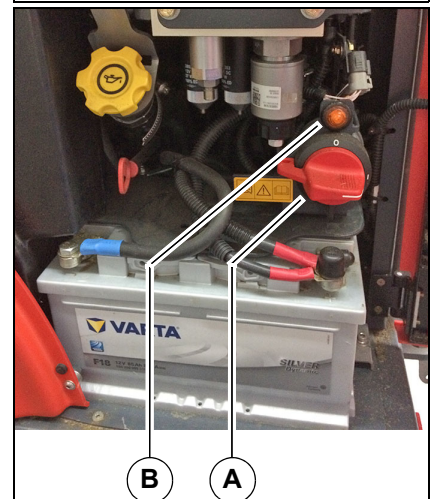


Fig. 116:

5.11 Lubrication plan

Item	Name
A	Door hinge left, right, above and below (4x)
B	Rigid upper link (2x)
C	Front lift cylinder left, right, top and bottom (4x)
D	Front lift bearing left/right (2x)
E	Adjustable upper link (2x) (optional)
F	Steering cylinder (4x)
G	Single-point lubrication system basic vehicle (1x) (optional) - (left side at articulated joint): <ul style="list-style-type: none"> • A1-A6=Left steering cylinder, rear upper link, front lift cylinder/bearing left • B1-A6=Right steering cylinder, front upper link, front lift cylinder/bearing right

Lubricating nipple

The lubricating nipple has a yellow protection cap. Clean the area around the grease nipple before lubricating!

Lubricants

Grease DIN 51825, KP 2N-20

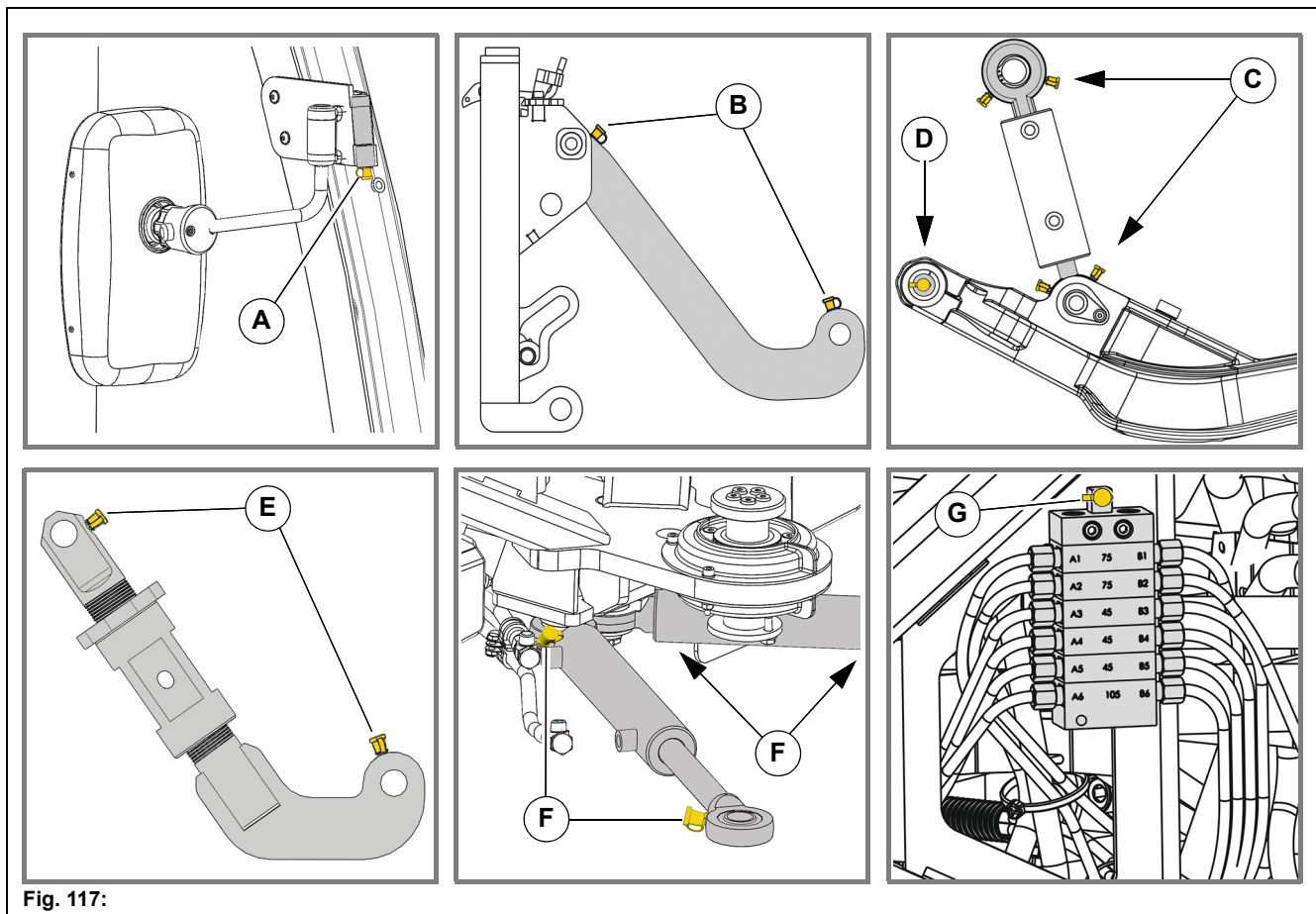


Fig. 117:

5.12 Cleaning the vehicle



Warning

- Danger of burns from hot parts! Do not touch any parts such as engine block, cooling system and exhaust system during operation and for some time after. Let the engine cool down.
- Use only dedicated washing places for cleaning the vehicle.

Attention

- When cleaning the engine with a water or steam jet cleaner, do not expose electrical plug connections and sensors, such as oil pressure switch, to a direct jet. Otherwise penetrating moisture can lead to corrosion and to failure of the measuring function!
- Never clean the driver's cab inside with a high-pressure cleaner, steam jet cleaner or with a strong water jet. Water under high pressure can:
 - Penetrate the vehicle electrical system and cause a short circuit.
 - Damage seals and make operating elements defective!

5.12.1 General notes

A distinction is made between 3 areas in vehicle cleaning:

- Driver's cab inside
- Complete vehicle outside
- Engine space

Here the wrong choice of cleaning equipment and agents can impair the operating safety of the vehicle and also endanger the health of the cleaning personnel. Therefore the following instructions should be followed without fail:

When using washing solutions

- Ensure sufficient room ventilation
- Wear suitable protective clothing
- Do not use any combustible liquids such as petrol or diesel fuel

When using compressed air

- Work carefully
- Wear eye protection and protective clothing
- Do not direct compressed air onto the skin or towards other persons
- Do not use compressed air for cleaning clothes

When using a high-pressure cleaner or steam jet cleaner

- Maintain a minimum distance of at least 30 cm!
- Max. pressure 120 bar at max. 80 °C
- Cover electrical parts and insulating mats and do not expose them to a direct jet
- Do not expose the venting filter of the hydraulic oil tank and lid of the fuel and hydraulic oil tank to a direct jet or cover these parts
- Protect the following components against moisture:
 - Electrical parts, such as three-phase generator, sensors, electrical plug connections, engine control unit, etc.
 - Control devices and seals
 - Air suction filter etc.

When using volatile and easily flammable anti-rust agents and sprays:

- Ensure sufficient room ventilation
- Use no naked fire or light!
- Do not smoke!

Care of the outside body

Wash your vehicle at regular intervals with water and a mild detergent. How frequently the vehicle has to be washed depends on the following factors:

- Area of use of the vehicle
- Driving on roads spread with salt
- Parking under trees with resinous excretions

Observe the following when washing:

- Do not use any coarse brushes or dirty cloths to prevent scratching and dulling the paintwork.
- Do not wash the vehicle if it has been exposed to sunshine for a long time, the paintwork could lose its gloss by this.

Cleaning plastic parts

Clean outer plastic parts like the vehicle. If dirt cannot be removed in this way, we recommend special plastic cleaners. You can also use these inside the vehicle for plastic parts.

Do not use any paint cleaners or products containing solvents, methanol or hydrocarbons.

Cleaning glass areas

Use special glass cleaners and clean cloths to avoid scratches and dulling.

Driver's cab inside

We recommend the following aids for cleaning the driver's cab:

- Vacuum cleaner
- Damp cloths
- Soft brush
- Bucket of water


Cleaning fabric surfaces

Remove dust on seats and other fabric surfaces with a soft brush or vacuum cleaner. More thorough cleaning can be achieved with special upholstery detergent. Observe the directions for use and danger notes of the manufacturer!


Solvents on a chlorine basis may not be used.

6 Attachments and Options

Safety instructions for attachments

	<p>Danger</p> <ul style="list-style-type: none"> • Danger to life in the danger area of the vehicle! Special caution is required in the vicinity of the articulated steering, beneath the raised tipper, in the vicinity of the front tool carrier, in the vicinity of the front and rear-mounted equipment and in the area between the vehicle and the trailer. • Risk of injury! Put the attachment into service only if all protective devices are attached and in protection position. • Risk of injury! Make sure that the attachments are suitable for the set oil volume. An oil volume set too high can lead to injuries due to a defect of the attachment! • Risk of injury! High-pressure hoses, fittings and couplings are important for equipment safety. Use only high-pressure hoses, fittings and couplings recommended by the manufacturer. • Risk of accident! When connecting attachments to the hydraulic system, ensure that the hydraulic hoses are connected correctly. Swapping the connections can lead to reverse functioning of the attachment, e.g. movement to the right rather than the left. • Risk of accident! Front attachments not correctly fastened to the front tool carrier can drop down while driving. Always secure the front attachment with the locking devices. • Risk of accident! You must consult Hako before attaching other attachments not approved by Hako! Check in the individual case that the relevant axial loads and total weights are complied with. • Risk of accident! Handling, steering and braking as well as stability are influenced by attachments, trailers and the vehicle payload (e.g. full dirt hopper). For this reason, pay attention to adequate steering and braking capability as well as stability. • Risk of accident! In Germany, if attachments extend beyond the outer lighting equipment of the vehicle or if the maximum distances of the outer lighting equipment specified according to StVZO are exceeded, the lighting equipment of the vehicle must be repeated (see Merkblatt StVZO § 30, explanations 11 and 12).
---	---

Safety instructions for ballast

	<p>Danger</p> <ul style="list-style-type: none"> • Risk of accident! When attaching other devices not approved by Hako, check in the individual case whether the relevant axle loads and total weights are complied with! • Risk of accident! The front axle of the working machine must always be loaded with at least 25% of the empty weight and the rear axle with at least 37% of the empty weight of the working machine. • Risk of accident! The front and rear attachments must not lead to exceeding the permissible total weight, the permissible axle load and the tyre load capacity of the working machine! <p>Warning</p> <ul style="list-style-type: none"> • Make sure before purchasing the attachment that these requirements are fulfilled by weighing the working machine attachment combination!
---	---

6.1 Vacuum sweeping system



Note

The vacuum sweeping system can be equipped with a 2-brush system or a 3-brush system. Any deviations due to the 3-brush system are listed accordingly at the respective position.

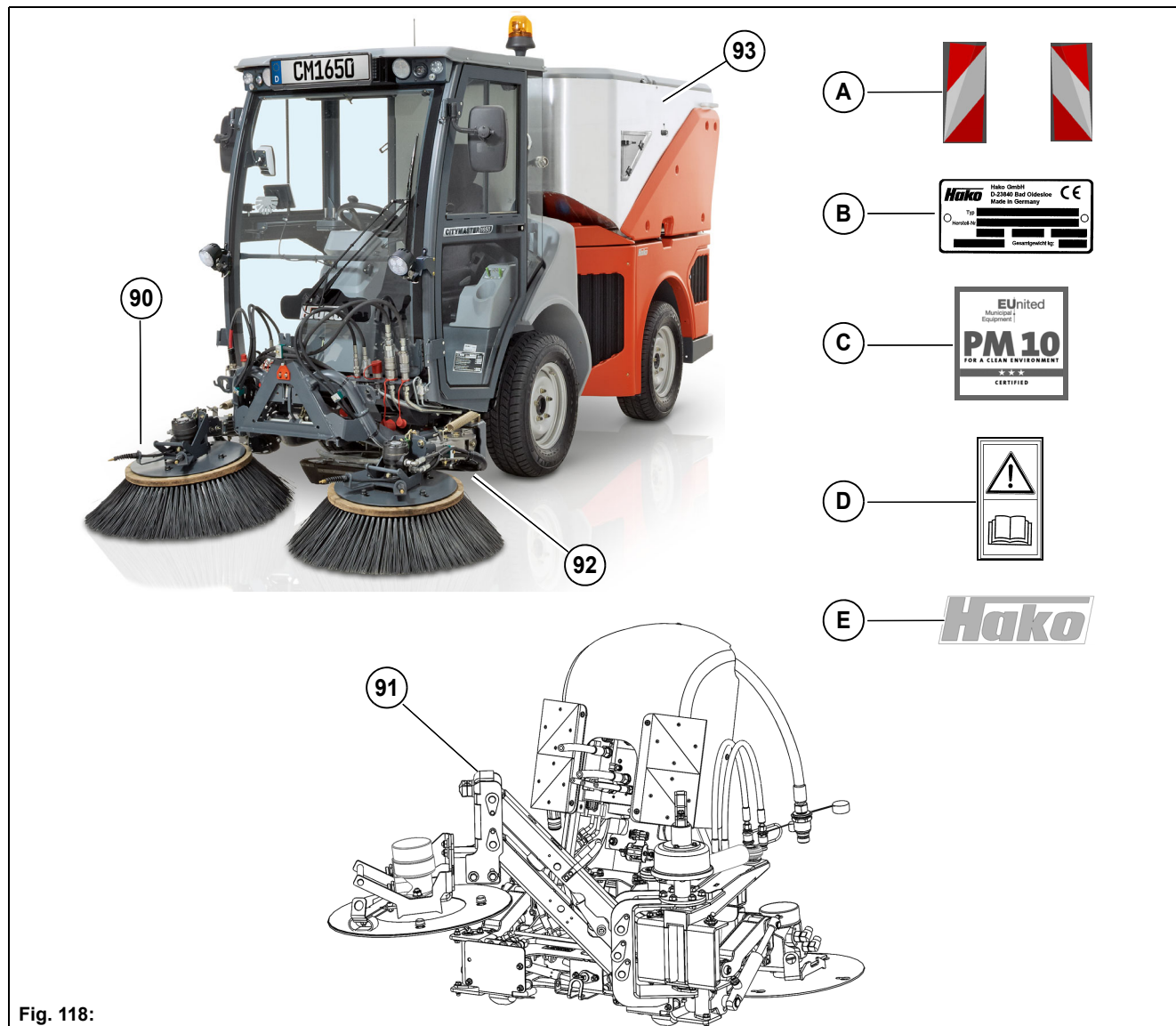


Fig. 118:

Item	Designation
90	Sweeping unit 2-brush system / Sweeping unit 2-brush system (comfort)
91	Sweeping unit 3-brush system
92	Sweeping unit suction mouth
93	Dirt hopper

6.1.1 Labels on the unit

Reflector

The reflectors (red/white) **Fig. 118-A** are located on the cover of the sweeping unit of the 2-brush system, the 3-brush system and at the back of the dirt hopper.

Type plate

The type plates **Fig. 118-B** are located on the sweeping unit of the 2-brush system, the 3-brush system, on the dirt hopper, on the trolley and on the supports.

Label PM10

The fine dust certificate label PM10 **Fig. 118-C** is located on the dirt hopper.

Label – Read operating manual

The label – Read operating manual **Fig. 118-D** is located on the sweeping unit of the 3-brush system.

Hako name plate

The Hako name plate **Fig. 118-E** is located on the sweeping unit of the 2-brush system and the 3-brush system.

6.1.2 Vacuum sweeping system safety instructions



Danger

- Danger to life in the danger area of the vehicle! Special caution is required under the raised tipper and in the area of the sweeping unit.
- Danger of tilting over when driving uphill or downhill and transversely to a slope! Avoid sudden turns when driving uphill or downhill or across slopes. There is a risk of tilting over on slopes of more than 20% with a loaded vehicle! The vehicle speed must always be adapted to the surrounding conditions and the load condition.
- Danger of tilting due to wrong steering! Note that the steering behaviour of an articulated steered vehicle differs essentially from that of a car. Sudden steering movements at high speed or too high speeds when turning can cause the vehicle to tilt over.
- Risk of injury! Frequently check the filling level of the dirt hopper. Switch the suction fan off for this! The lid and the side doors of the dirt hopper must not be opened when the suction fan is running.
- Risk of accident! Make transport journeys only with the sweeping unit raised and secured in the transport position.
- Risk of accident! Make transport journeys only with a completely lowered dirt hopper!
- Risk of accident! The stability of the vehicle is influenced by a filled dirt hopper. Handling of the vehicle must be adapted accordingly.
- Risk of accident! Do not exceed the permissible total weight of the vehicle!
- Risk of accident! When the dirt hopper is emptied, the Citymaster 1650 must be on a sufficiently load bearing, horizontal surface. Driving with the dirt hopper tilted is not permitted.

Warning

- When removing blockages in the suction hose or attaching the hand suction hose (optional), switch off the engine and wait for the suction fan to come to a standstill.
- The vacuum sweeping system may be operated only in connection with the Citymaster 1650. The safety regulations for the Citymaster 1650 must be complied with absolutely.

Caution

- The labels attached to the vehicle provide important information for safe operation. Renew labels that are no longer legible or present.
- Spare parts must be original spare parts to guarantee safety.

6.1.3 Mounting

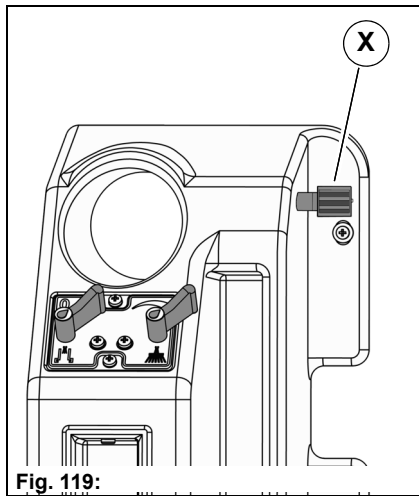


Fig. 119:

Mounting the suction mouth



Note

If circulating water is in the dirt hopper, the circulating water must be shut off using the ball cock Fig. 120-10!

1. Place the vehicle on a level surface and hold it with the parking brake.
2. Raise the front tool carrier and fix it in the upper position with the lowering valve Fig. 119-X.
3. Position the suction mouth Fig. 120-92 by hand or with the auxiliary tool Fig. 120-A centrally under the holding plate Fig. 120-B.
4. Open the valve Fig. 120-H. Push the joystick Fig. 120-74 forwards. When the valve is open, the holding plate is lowered onto the suction mouth.
5. Shift the suction mouth centrally under the holding plate until the stops Fig. 120-C come up to the points Fig. 120-D.
6. With the lever Fig. 120-E lock and secure the suction mouth on the counter bearing Fig. 120-F of the holding plate, see sketch Fig. 120-G.
7. Open the lowering valve Fig. 119-X again.

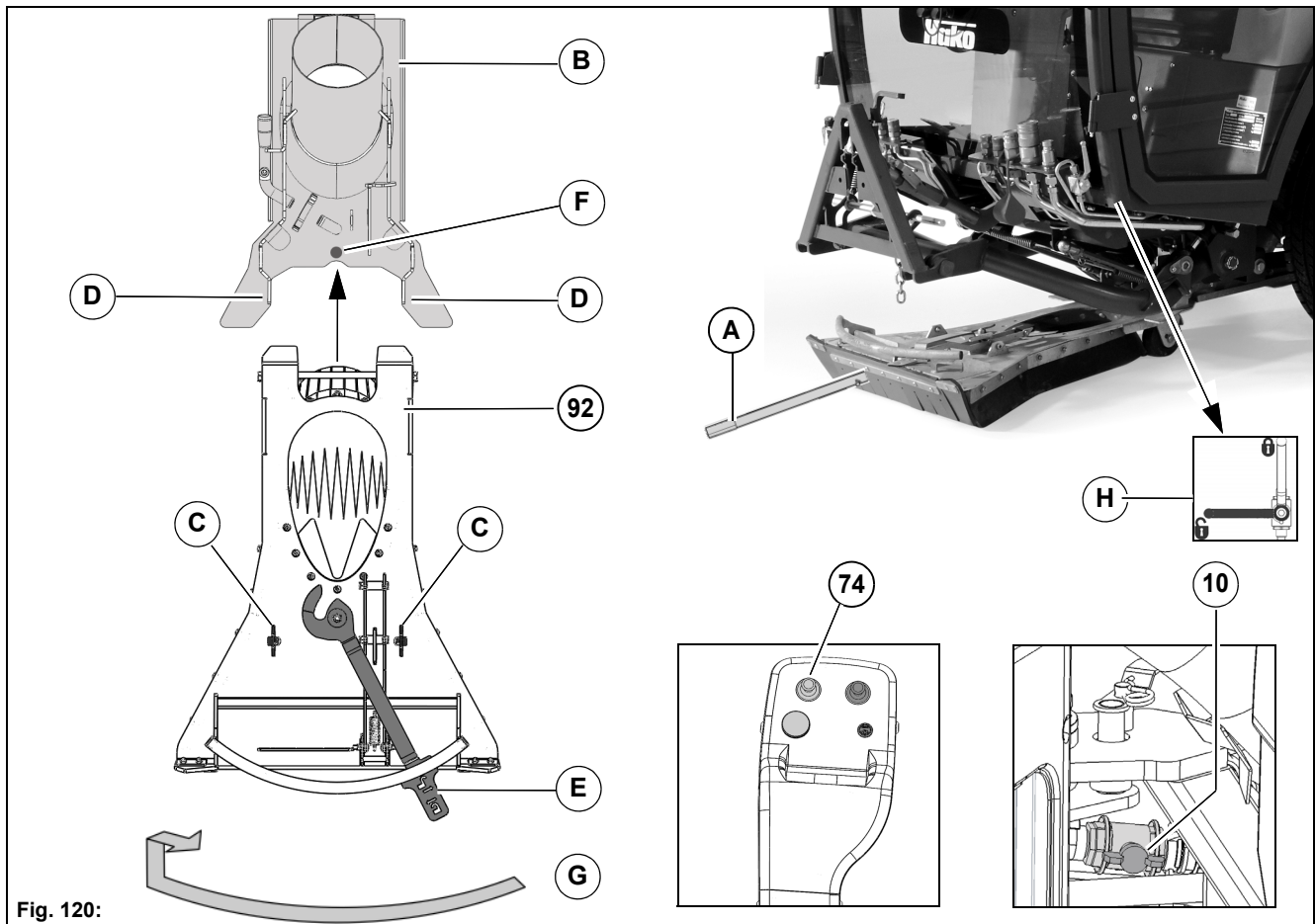


Fig. 120:

Mounting the sweeping unit (2-brush system)

1. Unlock the locking hook **Fig. 121-A** and locking rod **Fig. 121-B** on the front tool carrier **Fig. 121-12**. Lower the front tool carrier with the joystick **Fig. 121-74**.
2. With the trolley **Fig. 121-C** (optional), align the sweeping unit **Fig. 121-90** centrally and in alignment with the front tool carrier.
3. With an adjustable upper link (optional), set the standard length, see page 76.
4. Raise the front tool carrier with the joystick **Fig. 121-74** and attach the sweeping unit.
5. Lock the sweeping unit with the locking hook and locking rod. Check the backlash on the locking hook, see **Fig. 121-E**, adjust if necessary with elongated holes.
6. Push down the upper part **Fig. 121-D** of the trolley and pull it out from the sweeping unit.

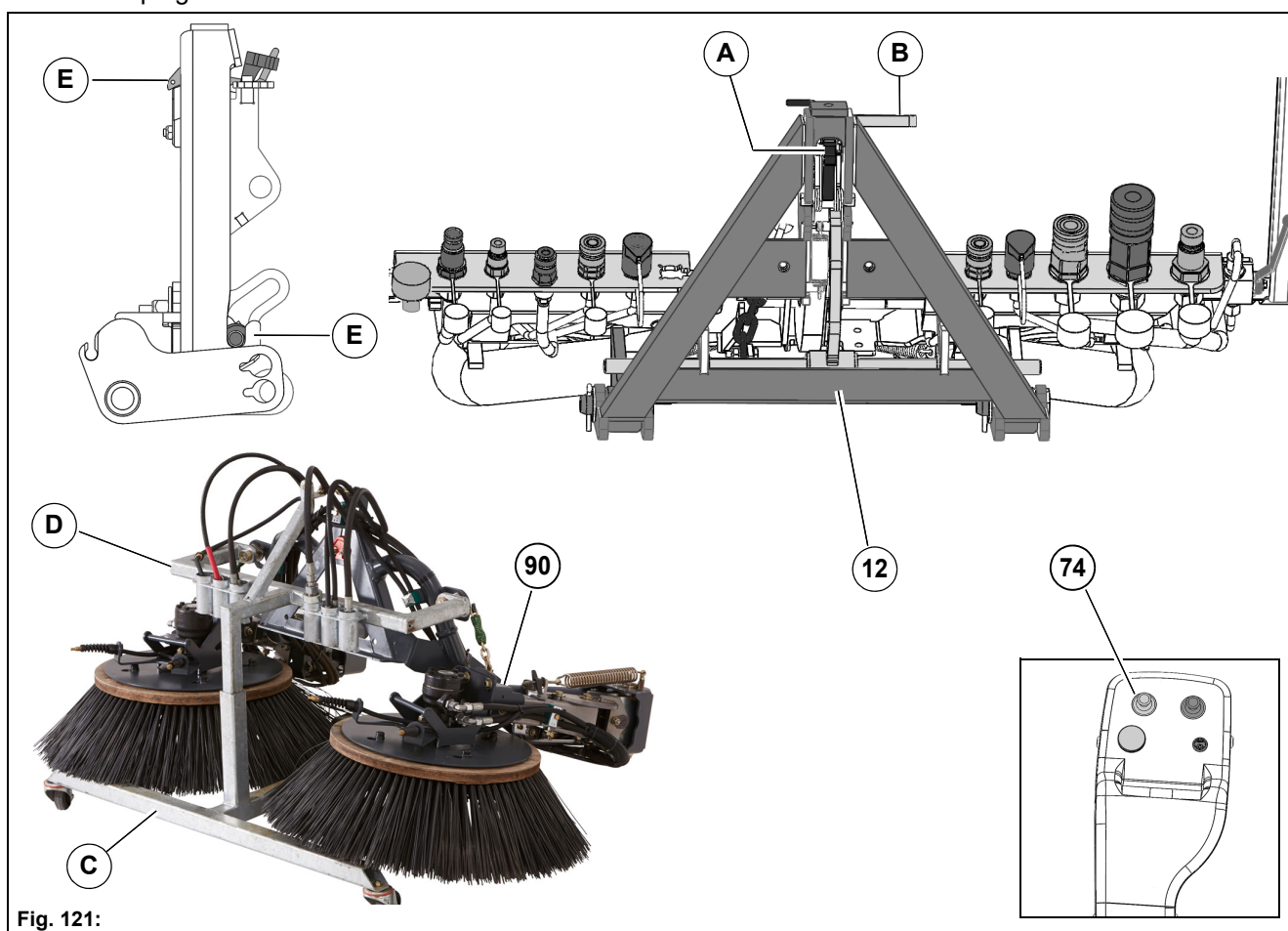


Fig. 121:

Continued – Mounting the sweeping unit (2-brush system)

7. Make the connections.

- Right actuator – Supply/return = **Fig. 122-D**
- Left actuator – Supply/return = **Fig. 122-D**
- 19-pin coding plug = **Fig. 122-F**
- Water connection for sweeping unit spray nozzles = **Fig. 122-G**
- Sweeping unit hydraulic motors – Supply/return = **Fig. 122-H**

8. Hook the chain **Fig. 122-M** in the first chain link. Lower the front tool carrier and drive the brush arms apart. Check that the edge **Fig. 122-N** stands vertically. Change the hooking position of the chain as required.

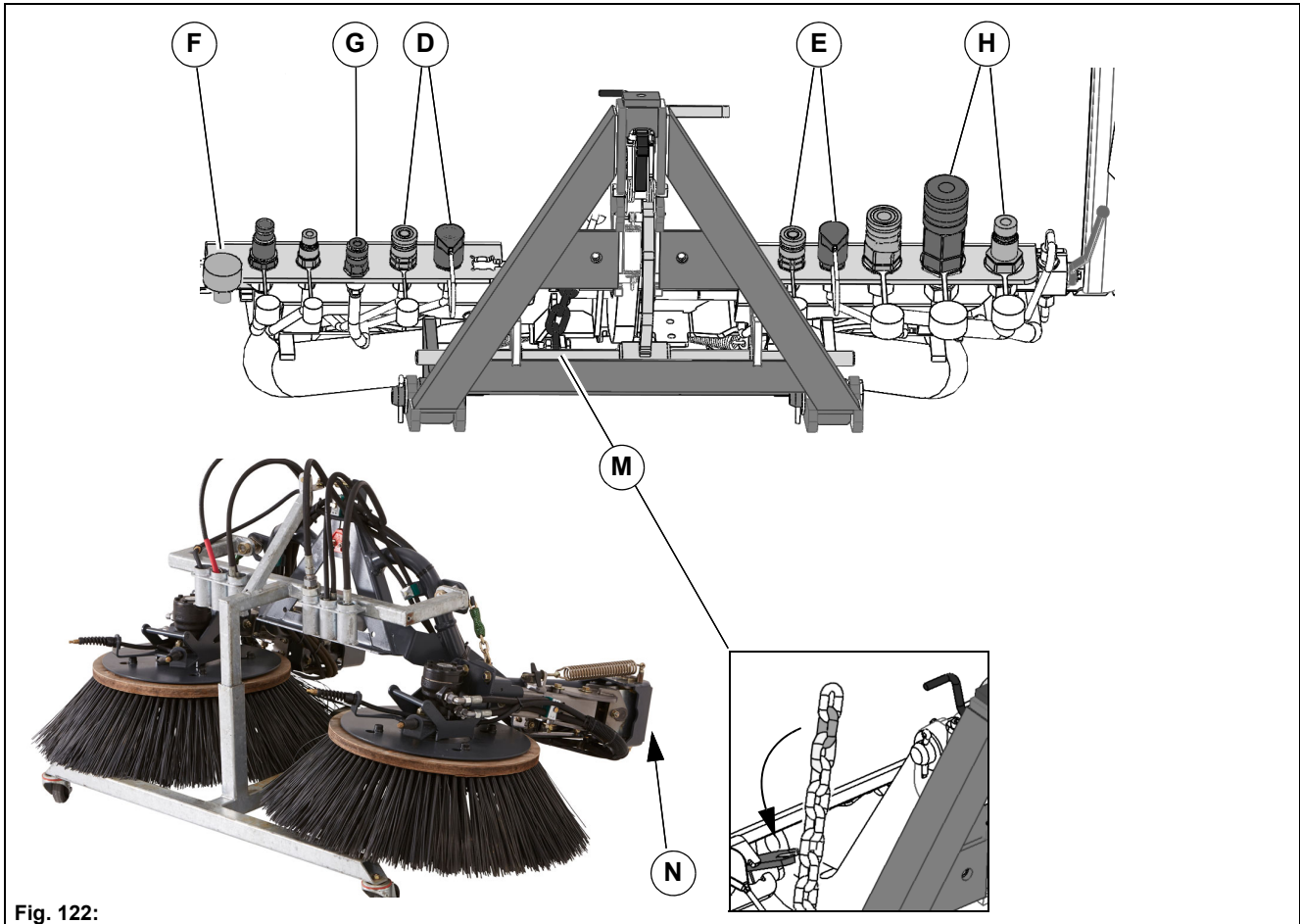


Fig. 122:

Mounting the sweeping unit (3-brush system)

1. Unlock the locking hook **Fig. 123-A** and locking rod **Fig. 123-B** on the front tool carrier **Fig. 123-12**. Lower the front tool carrier with the joystick **Fig. 123-74**.
2. With the trolley **Fig. 123-C** (optional), align the sweeping unit **Fig. 123-91** centrally and in alignment with the front tool carrier.
3. With an adjustable upper link (optional), set the standard length, see page 76 (Set the arm **Fig. 123-D** of the sweeping unit parallel to the floor).
4. Raise the front tool carrier with the joystick **Fig. 123-74** and attach the sweeping unit.
5. Lock the sweeping unit with the locking hook and locking rod. Check the backlash on the locking hook, see **Fig. 123-E**, adjust if necessary with elongated holes.
6. Disassemble the bolts **Fig. 123-F** of the trolley and pull the trolley out from the sweeping unit.

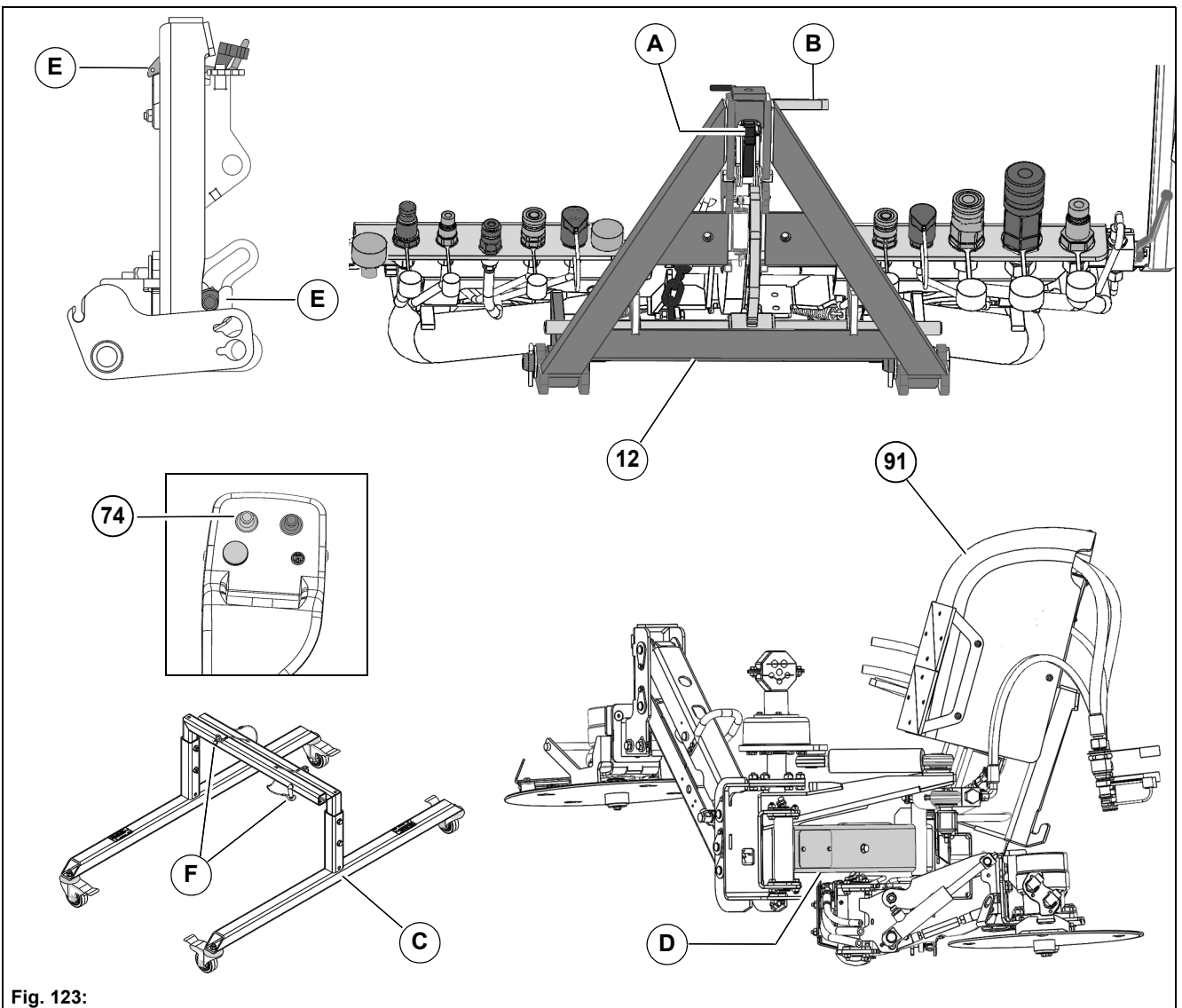


Fig. 123:

Continued – Mounting the sweeping unit (3-brush system)



Note

For the 3-brush system, the front tool carrier must be fixed in the upper end position. After mounting, move the front tool carrier to the upper end position and close the lowering valve **Fig. 124-F**.

7. Make the connections.

- Supply control unit 3-brush system = **Fig. 124-A**
- LS for control unit 3-brush system = **Fig. 124-B**
- Water connection for spray nozzles = **Fig. 124-C**
- Actuator – supply/return = **Fig. 124-D**
- Return control unit 3-brush system = **Fig. 124-E**
- 9-pin plug = **Fig. 124-X66**
- 19-pin coding plug = **Fig. 124-X63**

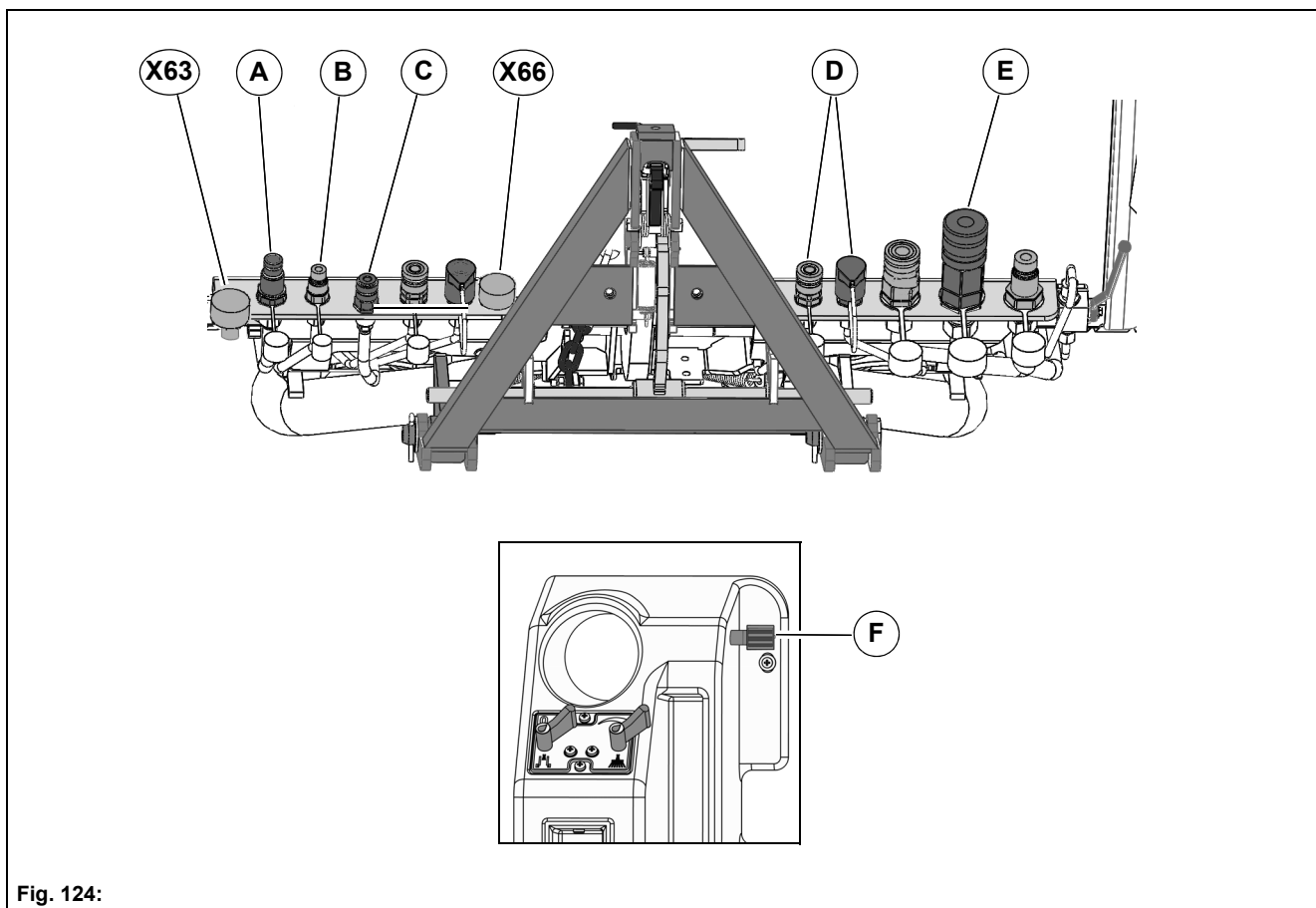



Fig. 124:

Mounting the dirt hopper

1. Place the vehicle on a level surface and hold it with the parking brake.
2. Unlock the lever **Fig. 125-A** of the trolley **Fig. 125-E** (optional) and swing it into the upper position.
3. Hold the lever **Fig. 125-A** in the upper position with one hand. With your other hand plug the mounting bolt **Fig. 125-B** on the Citymaster 1650.

	<p>Danger Risk of injury! The lever Fig. 125-A can swing over.</p>
---	--

4. Unlock the sledge **Fig. 125-C** with the lever and push it into the rear position.
5. Open the lock of the lid on the dirt hopper **Fig. 125-D** and swing the lid up.

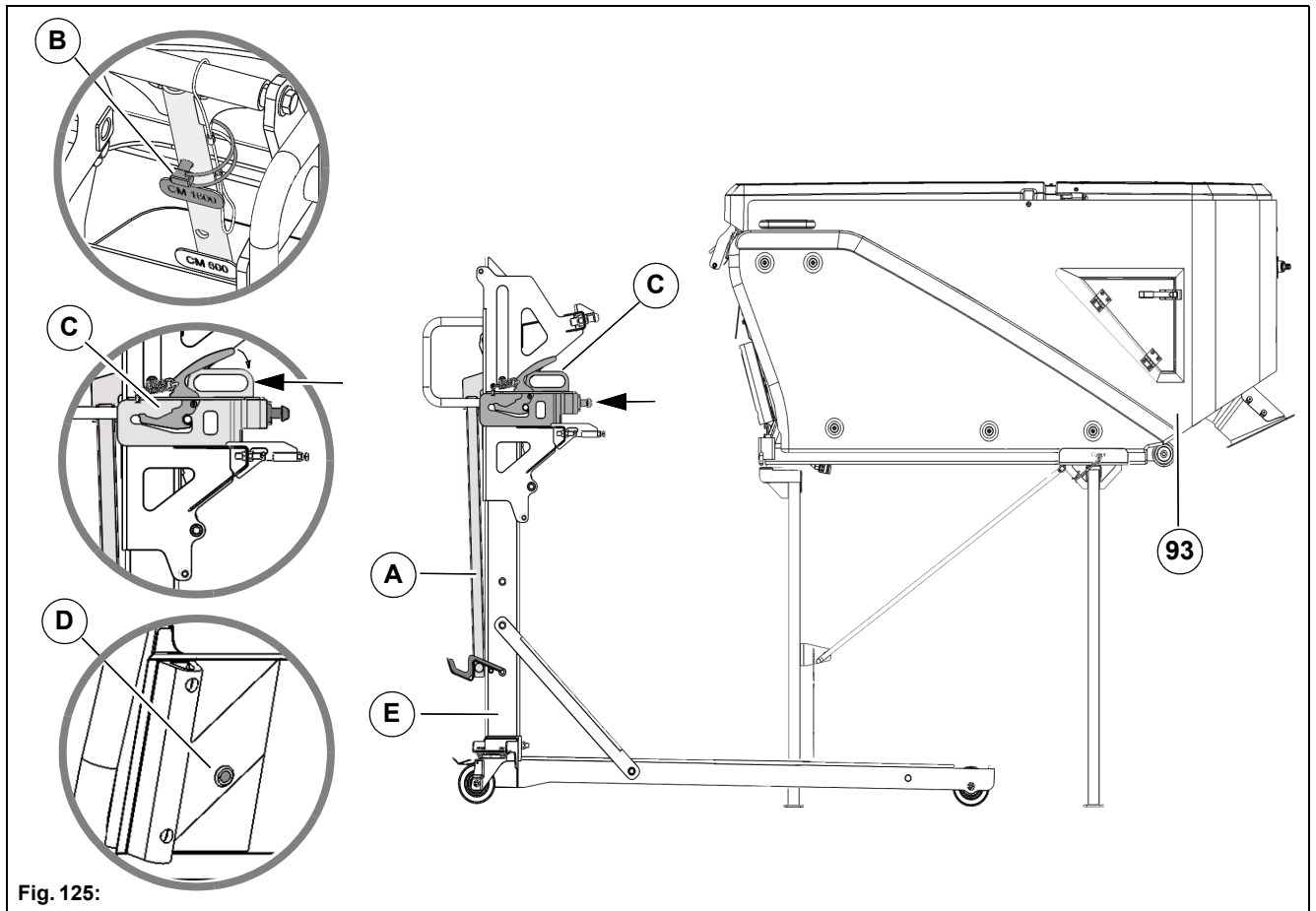




Fig. 125:

Continued – Mounting the dirt hopper

	<p>Danger Risk of injury due to tilting over! Make sure that the cross strut Fig. 126-D (optional) has been inserted when transporting the dirt hopper on the supports Fig. 126-L. Secure the supports with bolts and splints.</p>
---	---

6. Push the trolley **Fig. 126-J** (optional) with the lower positioning aid **Fig. 126-E** into the spars **Fig. 126-G** and against the fixed bearings **Fig. 126-H** of the dirt hopper. The screw **Fig. 126-F** must be adjusted to 38.5 mm!
7. Carefully lower the lever **Fig. 126-A** of the trolley and make sure that the upper positioning aid **Fig. 126-I** sits behind the plate **Fig. 126-J** of the dirt hopper. Lock the lever.
8. Remove the supports **Fig. 126-L**. To do this, pull out the split pins and the bolts.

	<p>Note During mounting protect the seal Fig. 126-K of the suction nozzle with a cover plate.</p>
---	---

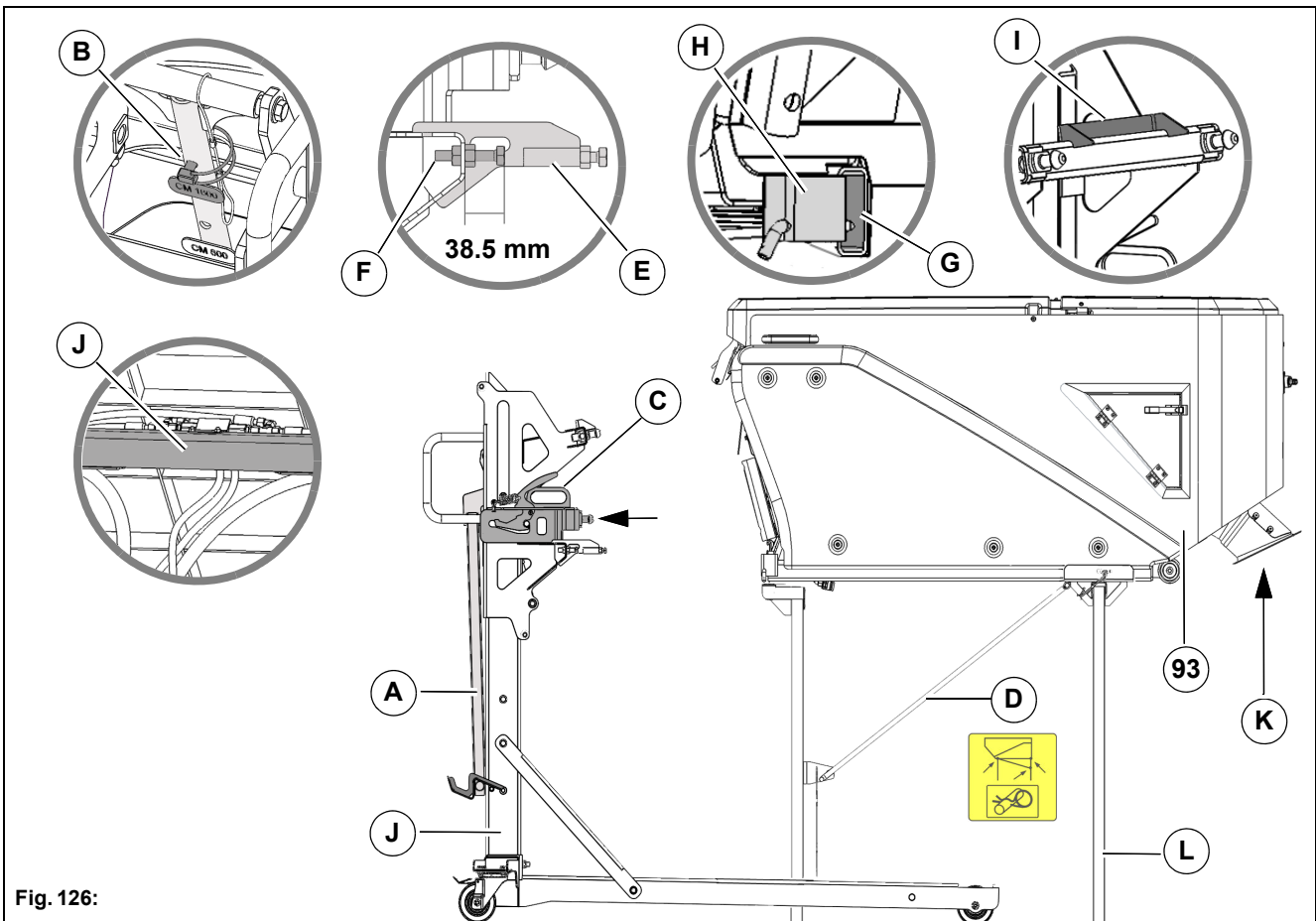


Fig. 126:

Continued – Mounting the dirt hopper

9. Align the dirt hopper to the rear wagon.

Procedure:

- Position the dirt hopper over the rear wagon and check the gap size **Fig. 127-X** with 5-10 mm. If necessary, correct with the screw **Fig. 127-A**.
- Push the rollers of the dirt hopper up into the pockets **Fig. 127-B**.
- The fixed bearings **Fig. 127-C** of the dirt hopper and the holders **Fig. 127-D** of the rear wagon must be in alignment.

10. Unlock the lever **Fig. 127-E** of the trolley **Fig. 127-I** (optional) and swing it into the upper position. Let the dirt hopper down slowly! Withdraw the trolley and close the lid.

11. Secure the dirt hopper with bolts and splints.

12. Make the connections.

- Lift system hydraulic cylinder – supply/return = **Fig. 127-F**
- Suction fan hydraulic motor – supply/return = **Fig. 127-G**
- Circulating water = **Fig. 127-H**

Dismantling is in the reverse order.

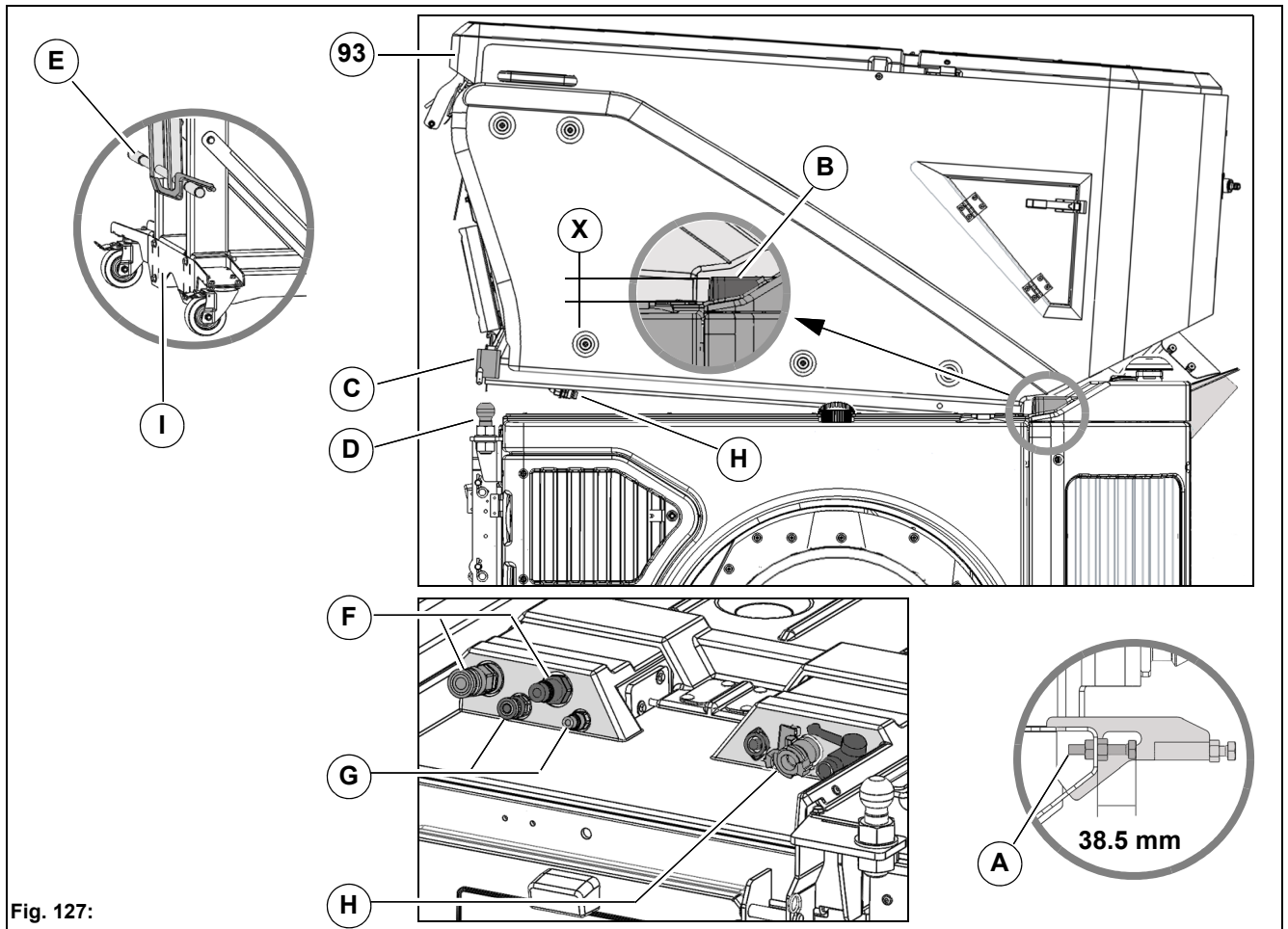


Fig. 127:

6.1.4 Operation

Checklist – Before start-up of the vacuum sweeping system

No.	Description	Reference
1	All items from the checklist Check before starting the vehicle	Page 83
2	Filling fresh water	Page 138
3	Filling circulating water	Page 139
4	Checking the ball cock circulating water	Page 139
5	Checking the transport protection device	Page 140
6	Checking the sweeping level	Page 163
7	Checking the rotating brush pressure	Page 162
8	Checking the suction mouth sealing strips	Page 164
9	Checking the suction duct seal	Page 165
10	Checking lubrication points	Page 165

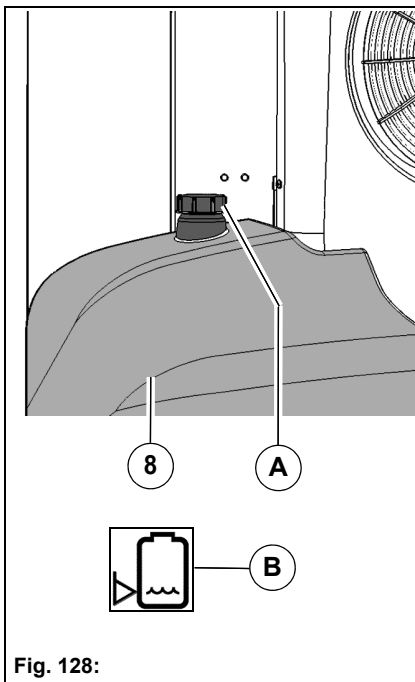


Fig. 128:

Filling fresh water

Open the cap **Fig. 128-A** and fill the fresh water tank **Fig. 128-8** until the level indicator in the multifunctional display shows maximum.

If the yellow warning symbol **Fig. 128-B** appears in the multifunctional display, the fresh water tank must be refilled.

Hydrant kit (optional)

Filling the fresh water tank from the public water mains with the D hose connection is possible with the hydrant kit (optional). The hydrant kit is mounted above the filling cap and contains a C hose connection, a D hose connection, an installation key and a free-fall section.




Note

Water may be taken from the mains of public water connections only through the "D-hose connection"!

Filling circulating water

1. Switch off the suction fan of the dirt hopper!
2. Open the lock **Fig. 129-A** of the dirt hopper.
3. Adjust the rear flap with the lever **Fig. 129-B**.
4. Fill the dirt hopper using a water hose. Use the side C hose connection as an alternative.
5. Fill the dirt hopper up to the mark of the plate **Fig. 129-C**. Filling volume for circulating water approx. 180 litres. After filling, check the function of the supply to the suction mouth.

	<p>Note</p> <p>Fill less circulating water into the dirt hopper when it is raining or wet. The vehicle sucks the remaining water off from the road when sweeping.</p>
---	--

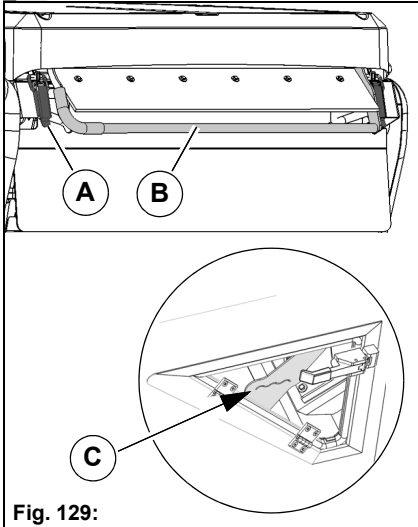



Fig. 129:

Checking the circulating water ball cock

The circulating water is closed off only with the ball cock for maintenance purposes. In normal operation the ball cock **Fig. 130-10** must be opened!

- Circulating water supply opened: ball cock in flow direction
- Circulating water supply closed: ball cock at right angles to the flow direction

	<p>Note</p> <p>Close off the circulating water supply only if there is circulating water in the dirt hopper and the suction mouth should be mounted or dismantled.</p>
--	---

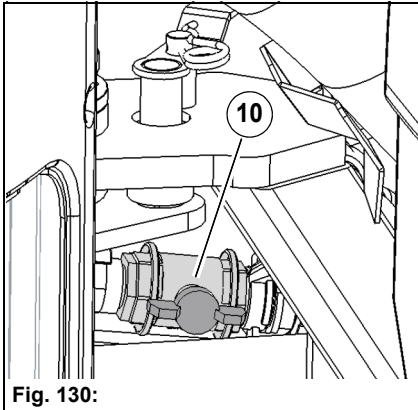
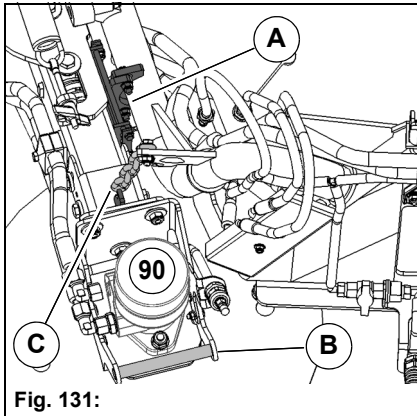


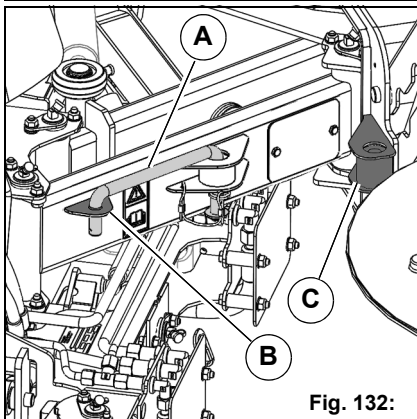
Fig. 130:



Checking the transport protection device (2-brush system)

The automatic transport protection device **Fig. 131-A** is located on the brush arms of the sweeping unit **Fig. 131-90** and has the task of moving the rotating brush up when the sweeping unit is raised.

The brush arms are locked automatically when the brush arms are swung down with the joysticks **Fig. 134-74** and **Fig. 134-75**. For reasons of safety, raise the brush arms with the handle **Fig. 131-B** and lock them with the chain **Fig. 131-C** before transporting.



Checking the transport protection device (3-brush system)

The bow **Fig. 132-A** of the transport protection device is located on the brush arm of the 3rd rotating brush.

- Position **Fig. 132-B** = for work mode
- Position **Fig. 132-C** = for transport mode

Before a transport journey, for safety reasons the 3rd rotating brush must be locked with the bow **Fig. 132-A**. Mount the bow in position **Fig. 132-C**.

Checklist – Vacuum sweeping

No.	Description	Reference
1	Driving to the work site	Page 141
2	Switching vacuum sweeping on	Page 141
3	Setting the fixed engine speed	Page 142
4	Starting vacuum sweeping	Page 142
5	Sweeping dry surfaces	Page 142
6	Sweeping wet surfaces	Page 142
7	Sweeping larger objects	Page 143
8	Changing the sweeping width	Page 143
9	Checking the overload protection	Page 145

Driving to the work site

1. Start the vehicle with the ignition switch **Fig. 133-82**.
2. As required, switch on the dipped headlight **Fig. 133-57**, working light **Fig. 133-58** and rotating beacon **Fig. 133-63**.
3. Prepare the transport mode. The brush arms must be swung in for the transport mode. For this, use the joysticks **Fig. 134-74** and **Fig. 134-75**. The sweeping unit must be in the upper end position. For this, use the joystick **Fig. 134-74**.
If the yellow warning symbol **Fig. 134-B** appears, the suction mouth must be raised with the joystick **Fig. 134-74**.
4. Check the transport protection device, see page 140.
5. Drive to the work site. The transport mode information symbol **Fig. 133-B** appears in the multifunctional display.
6. Loosen the transport protection device, see page 140.

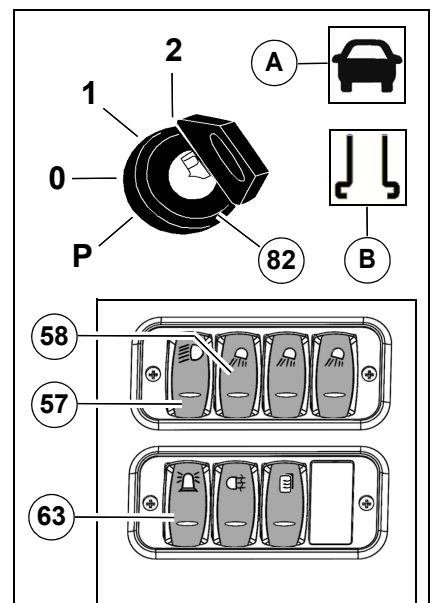


Fig. 133:

Switching vacuum sweeping on

Switch on the work mode with the Hako button **Fig. 134-76**. The accelerator pedals must be in the neutral position. In the multifunctional display, the information symbol for the vacuum sweeping system work mode **Fig. 134-A** appears as 2-brush system or **Fig. 134-B** as 3-brush system.

For a coded attachment, the Citymaster 1650 can automatically activate the following functions through the Hako button:

- The rotating brushes are lowered (floating position)
- The rotating brush drives are switched on
- The rotating brush speed is activated
- The fresh water pump is switched on
- The circulating water supply is switched on
- The suction fan is switched on

The fresh water supply is interrupted and the rotating brush stopped if the driver leaves the driver's seat! Restarting by pushing the left joystick **Fig. 134-74** forwards.

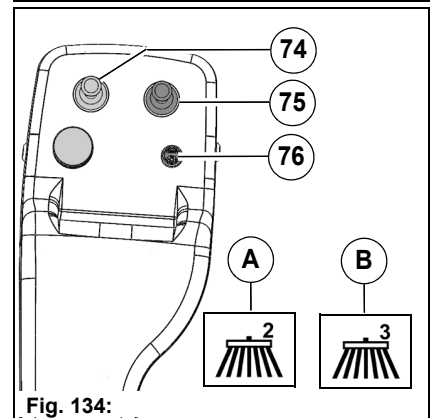


Fig. 134:

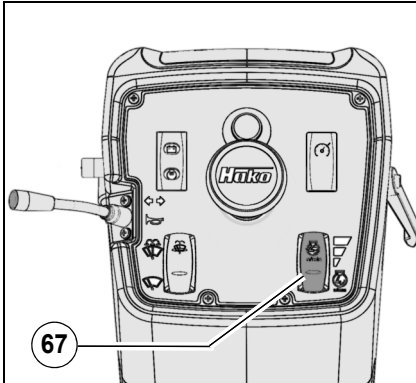


Fig. 135:

Setting the fixed engine speed

The fixed engine speed is set with the tip switch **Fig. 135-67**. Set the speed according to the requirements.

Stage	rpm	Use
1 - ECO	1600	Slight soiling/operation on flat ground
2 - Standard	2000	All soiling/operation on medium slopes
3 - Maximum	2400	All soiling/operation on steep slopes

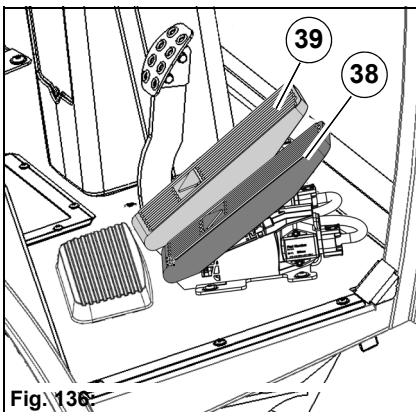


Fig. 136:

Starting vacuum sweeping

The accelerator pedal **Fig. 136-38** is used for continuously changing the speed for driving forwards.

The accelerator pedal **Fig. 136-39** is used for continuously changing the speed for reversing.

Push the accelerator pedal down slowly until the vehicle starts, the speed is increased further by pressing on the pedal.

Slowing down or braking the vehicle: slowly reduce the pressure on the accelerator pedal, the vehicle slows down or stops.

The vehicle speed in the:

- transport mode is 0 to 40 km/h,
- work mode 16/20/27 km/h according to selected engine speed.

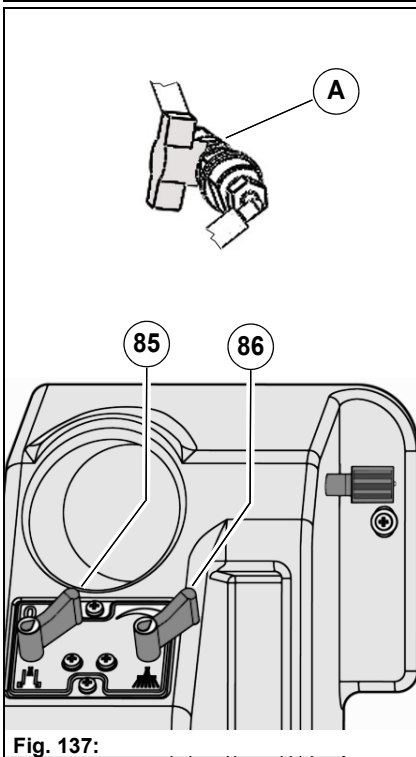


Fig. 137:

Sweeping dry/wet surfaces

To avoid the formation of dust, circulating water and fresh water are available in vacuum sweeping. The circulating water is supplied to the suction duct. Switch on the fresh water pump in the working menu, see page 153. The fresh water is supplied to the sweeping unit. The volume of fresh water for the spray nozzles of the sweeping unit is set with the lever **Fig. 137-86**.

Set the volume corresponding to the requirements.

- Less dust formation at the rotating brushes – reduce fresh water volume with the lever.
- Severe dust formation at the rotating brushes – increase the fresh water volume with the lever.
- Fresh water can be supplied between the rotating brushes by a fresh water nozzle with the lever **Fig. 137-A** of the sweeping unit.
- If no circulating water is available, fresh water can be switched on optionally for the suction duct with the lever **Fig. 137-85**.

	<p>Note</p> <p>Dry leaves can be swept best of all at medium suction fan speed. The suction power is sufficient and the coarse sieve on the suction fan of the dirt hopper does not clog so quickly.</p>
--	---

Sweeping larger objects

If there are larger objects or coarse dirt (cans, bottles, leaves, etc.) in front of the suction mouth, you can open the coarse material flap on the suction mouth by pressing down on the pedal **Fig. 138-48**.

The pedal can be locked by shifting it to the right when it is operated. Pushing and shifting the pedal to the left with your foot will unlock it.

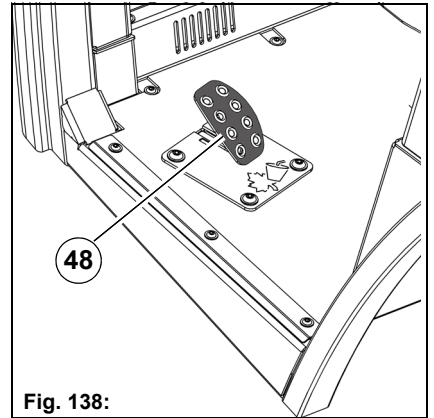


Fig. 138:

Changing the sweeping width (sweeping unit 2-brush system)

The sweeping width can be changed with the joystick **Fig. 139-74** and **Fig. 139-75** in the armrest.

1st rotating brush and 2nd rotating brush:

- Joystick **Fig. 139-74** to the left/right – the left rotating brush swings out/in
- Joystick **Fig. 139-75** to the left/right – the right rotating brush swings in/out

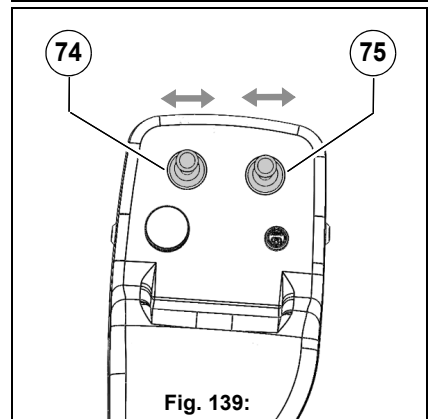


Fig. 139:

Adjusting the tilt of the rotating brush (sweeping unit 2-brush system (comfort))

This adjustment is only possible with the option sweeping unit 2-brush system (comfort).

Adjust the tilt of the rotating brush with the joystick **Fig. 140-75** in the armrest.

- Press the tip switch **Fig. 140-C** and simultaneously move the joystick **Fig. 140-75** to the right - the right-hand rotating brush tilts downwards
- Press the tip switch **Fig. 140-C** and simultaneously move the joystick **Fig. 140-75** to the left - the right-hand rotating brush moves back to the starting position

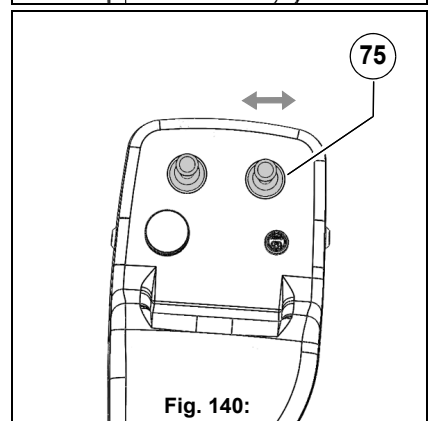


Fig. 140:

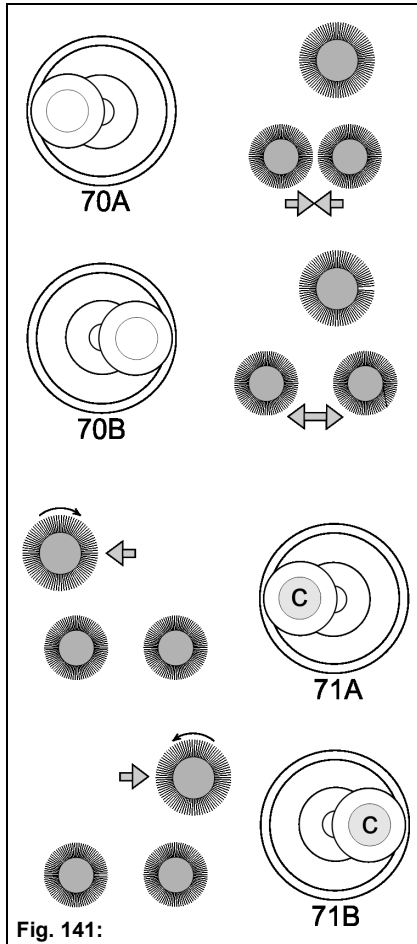


Fig. 141:

Changing the sweeping width (sweeping unit 3-brush system)

The sweeping width can be changed with the joystick **Fig. 140-74** and **Fig. 140-75** in the armrest.

1st rotating brush and 2nd rotating brush:

- Move the joystick **Fig. 141-74 (A)** to the left – the pulled rotating brushes swing in.
- Move the joystick **Fig. 141-74 (B)** to the right – the pulled rotating brushes swing out.

3rd rotating brush:

- Changeover to the left-hand side: Press the button **Fig. 141-C** and simultaneously move the joystick **Fig. 141-75 (A)** to the left. The 3rd rotating brush pivots to the left-hand side. The direction of rotation of the 3rd rotating brush is adjusted automatically.
- Move the joystick **Fig. 141-75** to the left or right. The 3rd rotating brush is adjusted to the relevant sweeping width.
- Changeover to the right-hand side: Press the button **Fig. 141-C** and simultaneously move the joystick **Fig. 141-75 (A)** to the right. The 3rd rotating brush pivots to the right-hand side. The direction of rotation of the 3rd rotating brush is adjusted automatically.
- Move the joystick **Fig. 141-75** to the left or right. The 3rd rotating brush is adjusted to the relevant sweeping width.

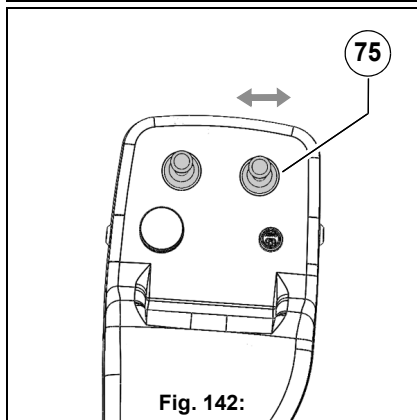


Fig. 142:

Adjusting the tilt of the rotating brush (sweeping unit 3-brush system)

This adjustment is only possible with the option sweeping unit system (comfort).


Adjust the tilt of the rotating brush with the joystick **Fig. 142-75** in the armrest.

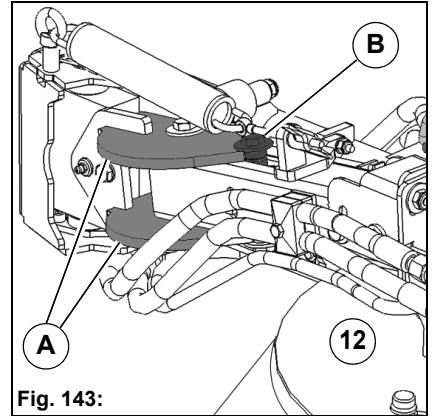
- Press the tip switch **Fig. 142-C** and simultaneously move the joystick **Fig. 142-75** to the right – the right-hand rotating brush tilts downwards.

Press the tip switch **Fig. 142-C** and simultaneously move the joystick **Fig. 142-75** to the left – the right-hand rotating brush moves back to the starting position.

Checking the overload protection (sweeping unit 2-brush system)


The overload protection device **Fig. 143-A** is located on the brush arm of the sweeping unit **Fig. 143-12** and has the task of protecting the sweeping unit in a collision. The overload protection device is unlocked in a collision. Before you can carry on working, you must lock the brush arm again. To do this, swing the brush arm until the overload protection device **Fig. 143-B** engages.

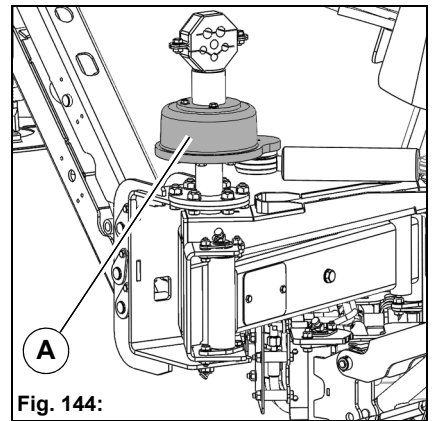
	<p>Note Check the sweeping unit for damage!</p>
---	--



Checking the overload protection (sweeping unit 3-brush system)

The overload protection device **Fig. 143-A** is located on the brush arm of the sweeping unit and has the task of protecting the sweeping unit in a collision. The overload protection device is unlocked in a collision. Before you can carry on working, you must lock the brush arm again. To do this, use the joystick to swing the brush arm until the overload protection device engages.

	<p>Note Check the sweeping unit for damage!</p>
---	--



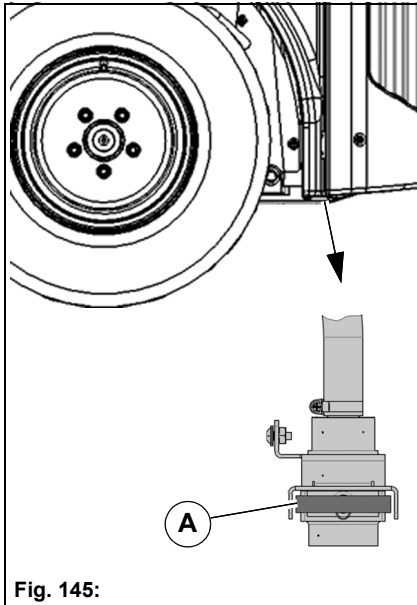


Fig. 145:

Circulating water drain (optional)

If vacuum sweeping is done in the rain and too much rain water is taken up, the surplus water can be drained off by a drain. The drain is located next to the wheel case of the right-hand rear wheel.

To open the drain, pull the handle **Fig. 145-A**. To close, push the lid back in.

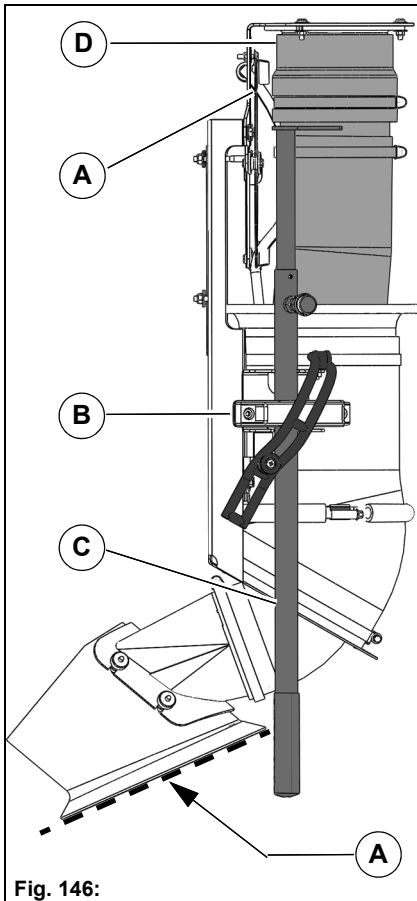


Fig. 146:

Hand suction hose (optional)

The 4 metre long hand suction hose **Fig. 146-D** is used for effectively cleaning places difficult to reach.

1. Start the vehicle and drive to the work site. Engage the parking brake. Switch the suction fan on, see page 153.
2. If necessary take the insert plate **Fig. 146-A** out from the holder and push it under the rubber seal.
 - Work with the insert plate in the case of heavy soiling. The suction force is increased. The circulating water supply is shut off with the suction mouth lifted.
 - Work without the insert plate in the case of slight soiling. With the suction mouth lowered, additional circulating water is supplied to bind the dust.
3. Loosen the lock **Fig. 146-B** and pull the hand suction hose down and out from the holder.
4. Hold the hand suction hose with the handle **Fig. 146-C** and clean the surface. If required, adjust the handle rod to length with the locking bolt. After cleaning push the hand suction hose against the holder. The hand suction hose withdraws automatically due to the vacuum.
5. If necessary fasten the insert plate back on the holder.
6. Close the handle rod.
7. Lock the hand suction hose again.

Hydraulic hand pump

The hydraulic hand pump **Fig. 147-A** is used for the following tasks:

- Raising and lowering the dirt hopper on failure of the vehicle hydraulics.
- Unlocking the parking brake for the towing process, see page 96



Note

A hexagon socket wrench (3 mm) is required for the setscrews of the valves **Fig. 147-Y17** and **Fig. 147-Y18**.

Raise the dirt hopper:

1. The lever of the hand pump **Fig. 147-A** must be in the lower position.
2. Screw in the setscrew in valve **Fig. 147-Y17** by 4 mm.
3. Insert the auxiliary tool in the hand pump **Fig. 147-C** and pump so long until the dirt hopper is in position.
4. Unscrew the setscrew in valve **Fig. 147-Y17** by 4 mm again.

Lower the dirt hopper:

1. The lever of the hand pump **Fig. 147-A** must be in the lower position.
2. Screw in the setscrew in valve **Fig. 147-Y18** by 4 mm.
3. Insert the auxiliary tool in the hand pump **Fig. 147-C** and pump so long until the dirt hopper is in position.
4. Unscrew the setscrew in valve **Fig. 147-Y18** by 4 mm again.



Caution

- The two setscrews of the valves **Fig. 147-Y17** and **Fig. 147-Y18** (rear wagon left side door) may not be screwed in too far (max. by 4 mm)!
- Do not screw in the setscrews simultaneously!
- In normal operation, both setscrews must be unscrewed by 4 mm again, see sketch!

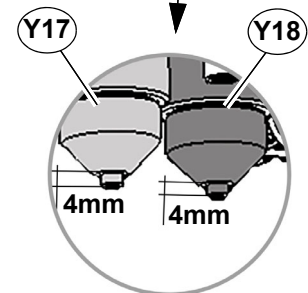
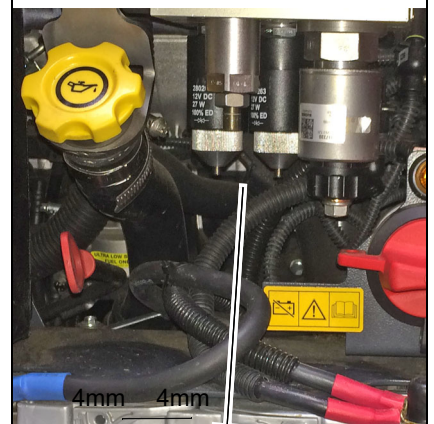
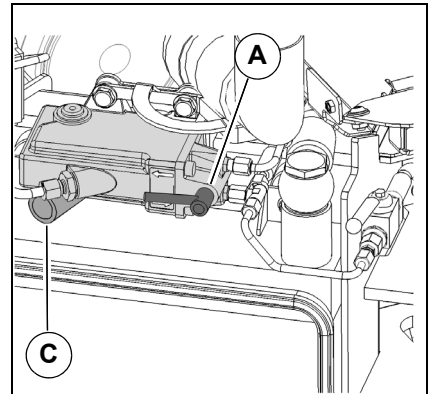


Fig. 147:

Comfort package for the dirt hopper (optional)

The comfort package contains the extended collision protection **Fig. 148-A** and the step **Fig. 148-B**.

Convenient inspection of the dirt hopper is possible with the folding step and the handles on the dirt hopper.

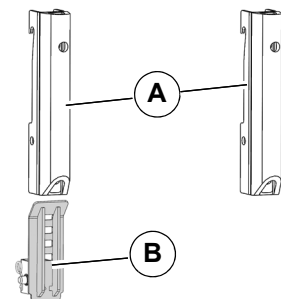


Fig. 148:

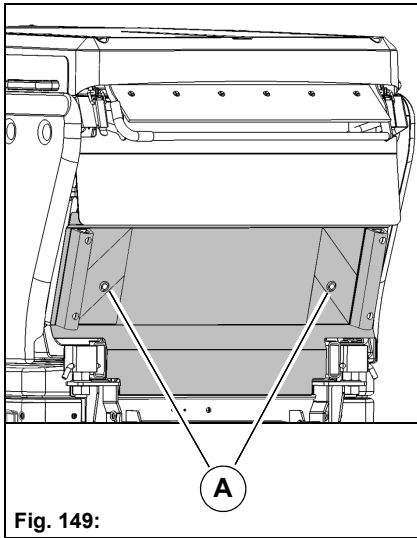


Fig. 149:

High-pressure cleaner (optional)

The high-pressure cleaner **Fig. 150-H** is located behind the rear flap of the dirt hopper. Check the following before starting up:

- Fill the fresh water tank, see page 138.
 - Check the water filter **Fig. 150-C** of the high-pressure cleaner and clean it if necessary.
1. Start the vehicle and drive to the work site. Engage the parking brake. Open the flap **Fig. 149-A**. Remove the pressure hose from the hose holder and plug it on at the connection **Fig. 150-B**.
 2. Set the changeover valve **Fig. 150-F** to the high-pressure cleaner position.
 - Position I: suction fan hydraulics
 - Position II: high-pressure cleaner hydraulics
 3. Open the fresh water supply **Fig. 150-D**.
 4. Switch the engine and suction fan on.
 5. Set the pressure controller **Fig. 150-A** to the required working pressure.
 6. Clean the surface with the lance **Fig. 150-G**.



Danger

The jet of the high-pressure cleaner must not be directed at persons. There is a risk of injury!
Do not use steam cleaners and high-pressure cleaners for cleaning electrical/electronic components and the engine compartment!

7. Reset the changeover valve to the suction fan position and close the fresh water supply again. After cleaning stow the lance and the pressure hose back in the stowage **Fig. 150-E**.

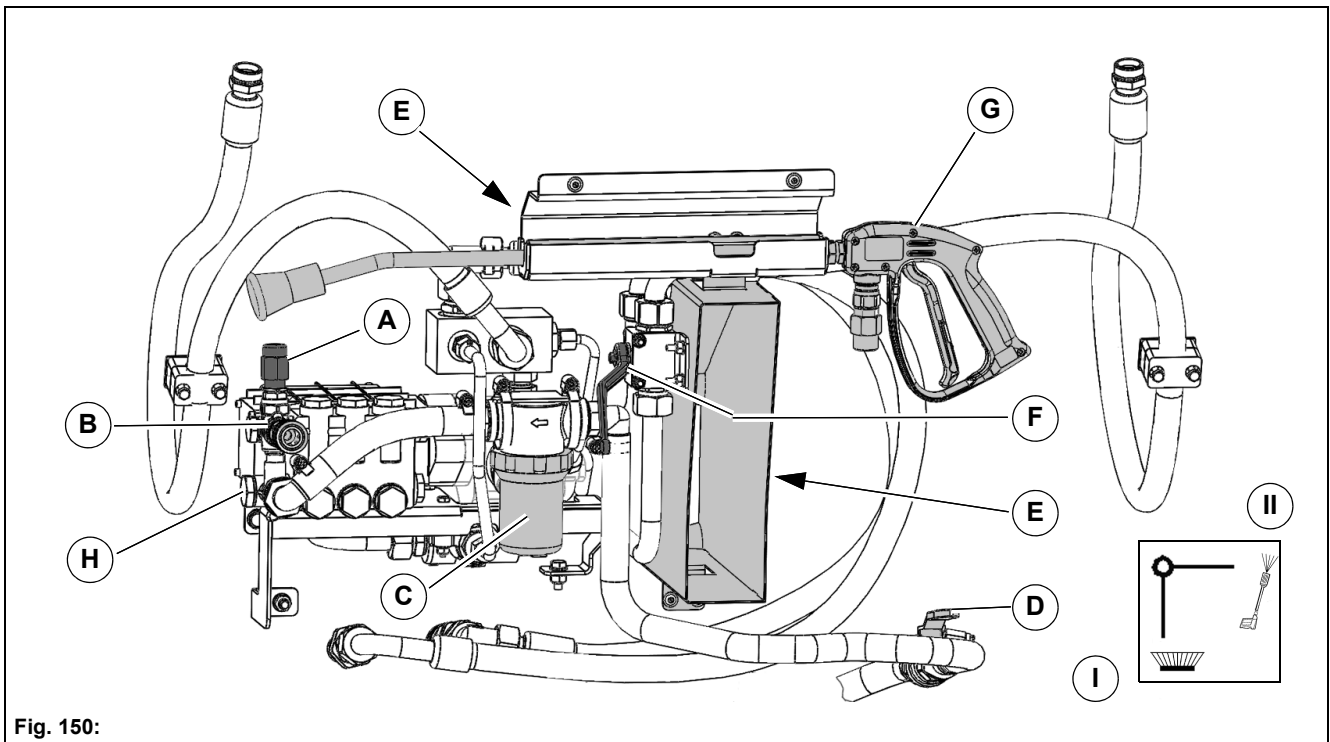


Fig. 150:

Checklist – Settings for vacuum sweeping

No.	Description	Reference
1	Adjusting the sweeping unit with the joystick	Page 149
2	Raising/lowering the dirt hopper	Page 149
3	Setting the rotating brush speed	Page 152
4	Switching the fresh water pump on and off	Page 153
5	Switching the suction fan on and off	Page 153

Adjusting the sweeping unit with the joystick (sweeping unit 2-brush system)

The sweeping unit can be adjusted with the joystick **Fig. 151-74** and **Fig. 151-75** in the armrest.

Joystick **Fig. 151-74**:

- Joystick forwards: lowering front tool carrier (floating position)
 - Joystick back: raising front tool carrier
 - Joystick to the left: the left-hand rotating brush swings out
 - Joystick to the right: the left-hand rotating brush swings in
- In the multifunctional display, the upper stop information symbol **Fig. 151-A** or floating position symbol **Fig. 151-B** appears.

Joystick **Fig. 151-75**:

- Joystick to the left: the right-hand actuator swings in
- Joystick to the right: the right-hand actuator swings out

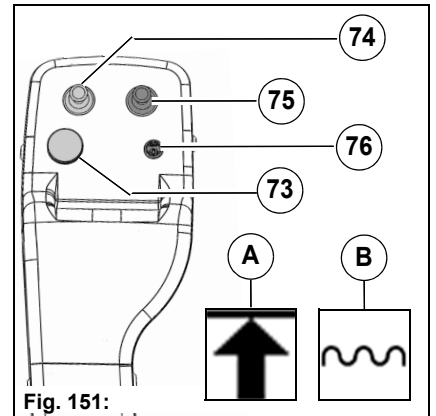


Fig. 151:

Raising/lowering the dirt hopper

The following functions on the dirt hopper are switched on with the button **Fig. 152-79**:

- Button in position I: the dirt hopper is raised until the button is released.
- Button in position II: the dirt hopper is lowered until the button is released.

	<p>Note The lock must be opened before you empty the dirt hopper, see page 154.</p>
--	--

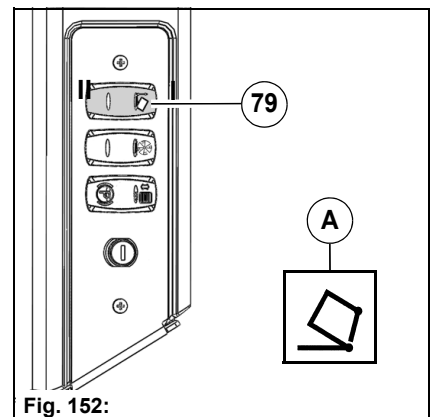


Fig. 152:

As long as the dirt hopper is not in its lower end position, the warning symbol **Fig. 152-A** appears.

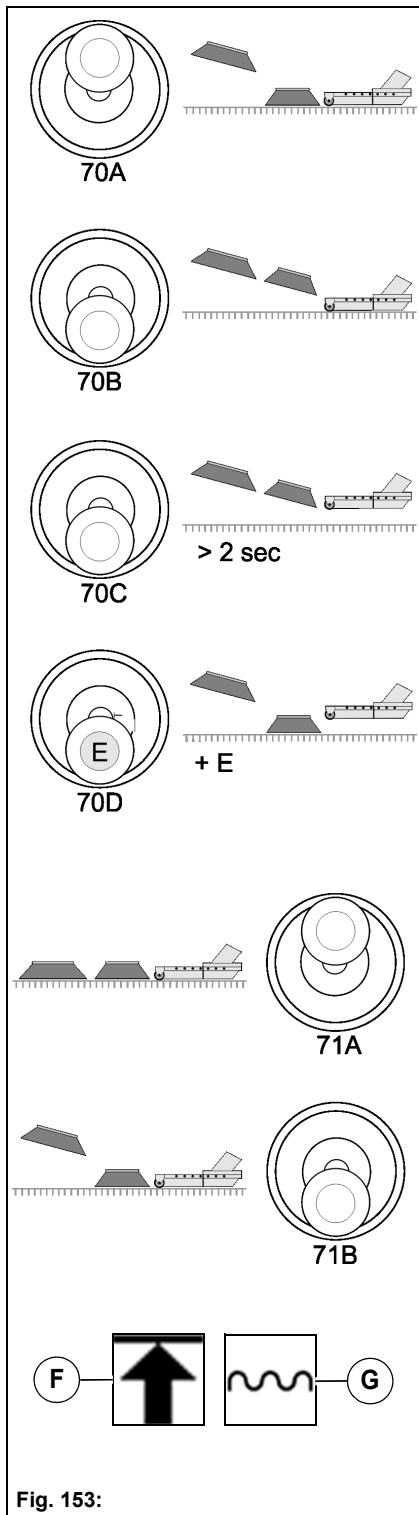


Fig. 153:

Adjusting the sweeping unit with the joystick (sweeping unit 3-brush system)

The sweeping unit can be adjusted with the joystick **Fig. 153-74** and **Fig. 153-75** in the armrest.

Joystick Fig. 153-74:

- Move joystick forwards into position **(70A)**: the pulled rotating brushes are lowered (floating position)
- Move joystick backwards into position **(70B)**: the pulled rotating brushes are raised
- Move joystick backwards into position **(70C)** and hold for more than 2 seconds: the pulled rotating brushes and the suction mouth are raised
- Move joystick backwards into position **(70D)** and press the button **(E)**: the suction mouth is raised

Joystick Fig. 153-75:

- Move joystick forwards into position **(71A)**: the 3rd rotating brush is lowered (floating position)
- Move joystick backwards into position **(71B)**: the 3rd rotating brush is raised

In the multifunctional display, the upper stop information symbol **Fig. 153-F** or floating position symbol **Fig. 153-G** appears.

1st rotating brush and 2nd rotating brush:

- Move the joystick **Fig. 154-74 (A)** to the left – the pulled rotating brushes swing in.
- Move the joystick **Fig. 154-74 (B)** to the right – the pulled rotating brushes swing out.

3rd rotating brush:

- Changeover to the left-hand side:
Press the button **Fig. 154-C** and simultaneously move the joystick **Fig. 154-75 (A)** to the left.
The 3rd rotating brush pivots to the left-hand side. The direction of rotation of the 3rd rotating brush is adjusted automatically.
- Move the joystick **Fig. 154-75** to the left or right.
The 3rd rotating brush is adjusted to the relevant sweeping width.
- Changeover to the right-hand side:
Press the button **Fig. 154-C** and simultaneously move the joystick **Fig. 154-75 (B)** to the right.
The 3rd rotating brush pivots to the right-hand side. The direction of rotation of the 3rd rotating brush is adjusted automatically.
- Move the joystick **Fig. 154-75** to the left or right.
The 3rd rotating brush is adjusted to the relevant sweeping width.

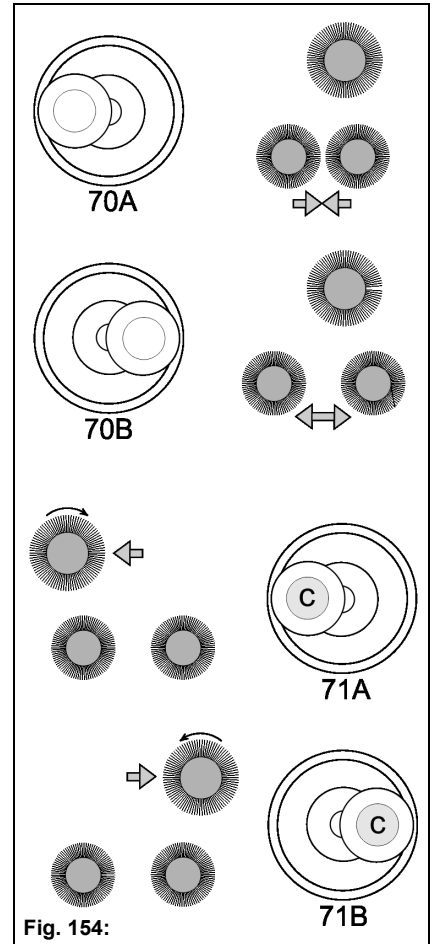


Fig. 154:

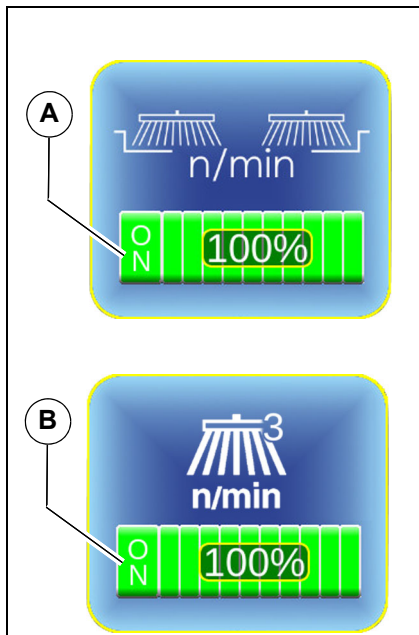


Fig. 155:

Setting the rotating brush speed

Select the working menu in the multifunctional display with the turn-push knob **Fig. 151-73**.

Change the current value in the brush speed menu **Fig. 155-A**.

If the right-hand joystick **Fig. 151-73** is used for the 3rd rotating brush with a 3-brush system, menu **Fig. 155-B** appears automatically.

Setting range: 0 to 100%

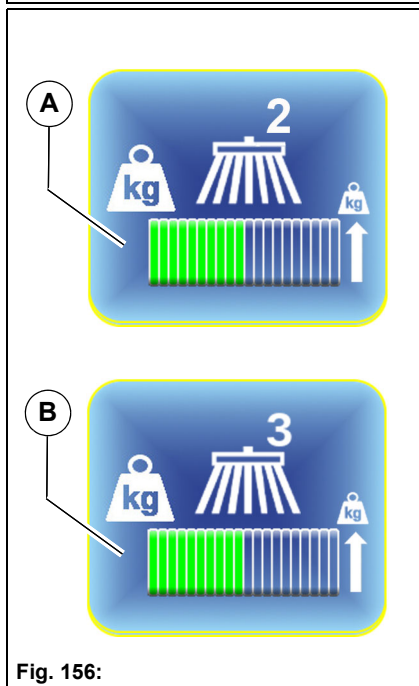


Fig. 156:

Adjusting the brush pressure (sweeping unit 3-brush system) (optional)

Using this option it is possible to reduce the brush pressure of the rotating brushes.

Select the working menu in the multifunctional display with the turn-push knob **Fig. 151-73**. Change the current value in the brush pressure menu. If the left-hand joystick is used for the 1st rotating brush and 2nd rotating brush with a 3-brush system, menu **Fig. 156-A** appears automatically.

If the right-hand joystick is used for the 3rd rotating brush with a 3-brush system, menu **Fig. 156-B** appears automatically.

The higher the setting, the more the brushes are relieved.

Setting range: 0 to 100%

Switching the fresh water pump on and off

Select the working menu in the multifunctional display with the turn-push knob **Fig. 151-73**. Change the current value in the fresh water menu **Fig. 157-A**.

Setting range: On/Off

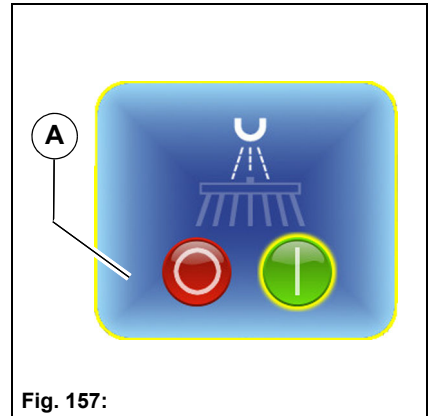


Fig. 157:

Switching the suction fan on and off

Select the working menu in the multifunctional display with the turn-push knob **Fig. 151-73**. Change the current value in the suction fan menu **Fig. 158-A**. Noise-reduced operation is obtained in the ECO mode when the suction fan output is reduced to 30%.

Setting range: On/Off or 30% to 100%.

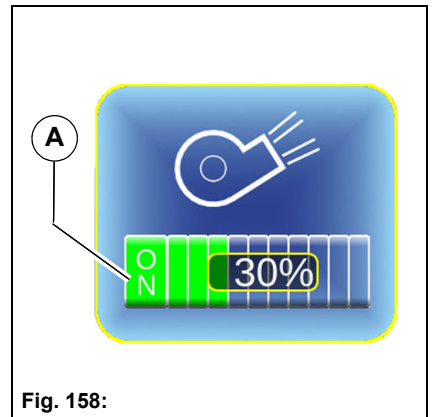



Fig. 158:

Checklist – Cleaning the vacuum sweeping system

No.	Description	Reference
1	Emptying the dirt hopper	Page 154
2	Cleaning the sweeping unit	Page 155
3	Cleaning the dirt hopper and circulating water system	Page 156
4	Emptying the fresh water tank	Page 156
5	Emptying the circulating water tank	Page 156

	<p>Caution</p> <ul style="list-style-type: none"> Do not exceed the permissible total weight. There is a risk of accidents! Frequently check the filling level of the dirt hopper. Switch the suction fan off for this! The lid and the side doors of the dirt hopper must not be opened when the suction fan is running. There is a risk of injury! <p>Attention</p> <ul style="list-style-type: none"> Do not use steam cleaners and high-pressure cleaners for cleaning electrical/electronic components and the engine compartment! The cleaning work listed below must be done after every emptying, at least once daily.
---	--

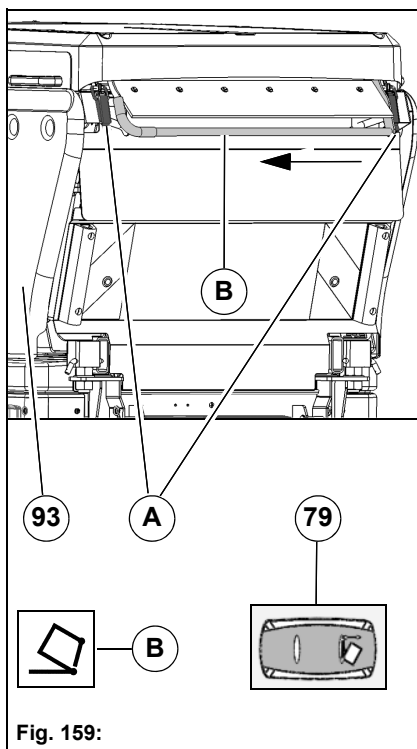


Fig. 159:

Emptying the dirt hopper

1. Lock the sweeping unit with the transport protection device, see page 140. Drive the vehicle to a suitable cleaning place.
2. Reverse carefully to the offloading place and engage the parking brake. Switch the suction fan off!
3. Before emptying the dirt hopper **Fig. 159-93** open the lock **Fig. 159-A** of the lid.
4. Raise and empty the dirt hopper with the button **Fig. 159-79**.
5. Lower the dirt hopper and lock the lid again.

Hopper overload (optional)

If the red warning symbol **Fig. 159-B** appears, the dirt hopper must be emptied immediately.

Cleaning the suction mouth

1. Lock the sweeping unit with the transport protection device, see page 140. Drive the vehicle to a suitable cleaning place.
2. Select the working menu in the multifunctional display with the turn-push knob. Switch the suction fan on in the suction fan menu.
3. Push a water hose into the suction mouth **Fig. 160-92** and loosen the dirt with the water jet. The dirt is drawn with the water into the dirt hopper.
4. Empty the dirt hopper, see page 154.

In the case of heavy soiling, dismantle and clean the suction mouth, see page 130.

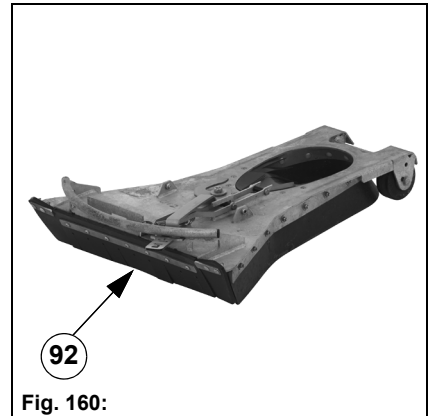


Fig. 160:

Cleaning the sieve filter reducing piece

In the driver's cab under the driver's seat behind the cover plate **Fig. 161-51** are located the sieve filter **Fig. 161-A** and the reducing piece **Fig. 161-B** of the water pump. Unscrew the filter housing, check the sieve filter and the reducing piece for openness and clean if necessary.

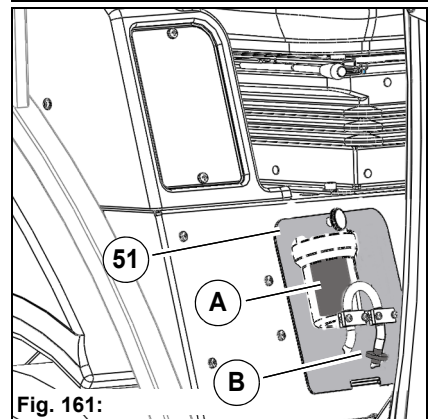


Fig. 161:

Cleaning spray nozzles and ball valve filter

The spray nozzles **Fig. 162-A** for the rotating brushes are located on the sweeping unit. A ball valve filter is located in the filter holder **Fig. 162-B** in front of a distributor. Dismantle and clean the spray nozzles and ball valve filter.

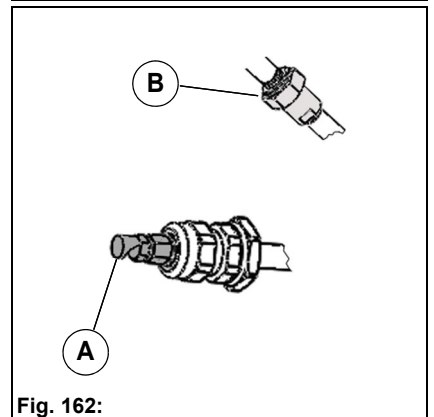


Fig. 162:

Cleaning the suction fan

1. Lock the sweeping unit with the transport protection device, see page 140. Drive the vehicle to a suitable cleaning place.
2. Connect a water hose to the water connection **Fig. 163-A** of the dirt hopper.
3. Push the Hako button **Fig. 8-76** and let the water be drawn as required by the suction fan into the dirt hopper.
4. Open the lid of the dirt hopper and raise the dirt hopper up to the end stop with the button **Fig. 8-79** and drain off the water taken up!

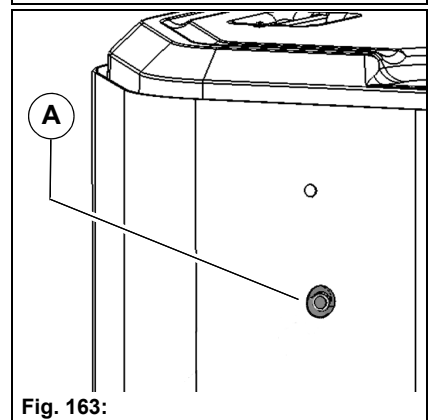


Fig. 163:

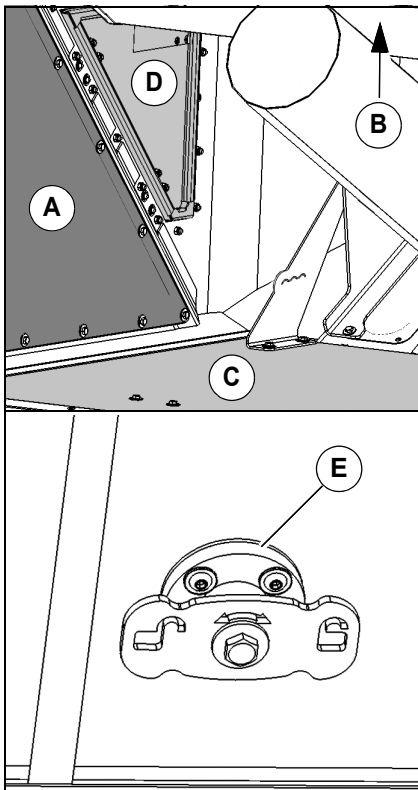


Fig. 164:

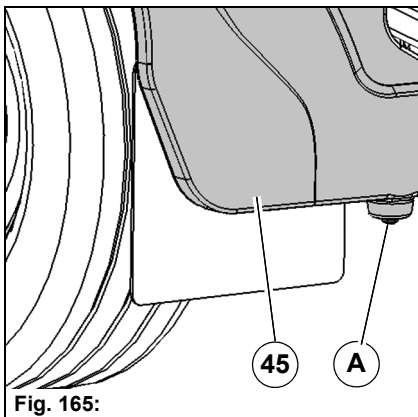


Fig. 165:

Cleaning the dirt hopper and circulating water system

1. Lock the sweeping unit with the transport protection device, see page 140. Drive the vehicle to a suitable cleaning place and empty it.
2. Half raise the dirt hopper and open the lock **Fig. 164-E** of the sump flap (hopper floor). Then bring the dirt hopper into its end position.
3. Clean the dirt hopper from the inside with a water hose or a high-pressure cleaner. Pay special attention to the lateral filter sieve **Fig. 164-A** and the filter sieve **Fig. 164-B** in the lid.
The dirt hopper can also be cleaned through the side doors **Fig. 164-D**. The suction fan of the dirt hopper must be switched off to open the doors!
Clean with the auxiliary tool as required or remove the contaminated filter sieve.
4. When the dirt hopper is raised, the valve of the settling tank **Fig. 164-C** opens. Clean the settling tank and flush trough the circulating water system with water.
5. Half lower the dirt hopper and close the sump flap lock.
6. Lower the sweeping unit fully with the joystick **Fig. 8-74** and let the water run until clear water emerges at the suction mouth.
7. Fill the dirt hopper with circulating water, see page 139.

Draining the fresh water

	<p>Note At temperatures below 0 degrees (risk of frost) drain the water out from all water-conducting components.</p>
--	--

1. Lock the sweeping unit with the transport protection device, see page 140. Drive the vehicle to a suitable cleaning place.
2. Unscrew the drain screws **Fig. 165-A** on both sides of the fresh water tank **Fig. 165-45** and empty the tank. Use a new seal when screwing in.
3. Also empty the sieve filter, **Fig. 161-A**.

Draining the circulating water

	<p>Note At temperatures below 0 degrees (risk of frost) drain the water out from all water-conducting components.</p>
--	--

1. Lock the sweeping unit with the transport protection device, see page 140. Drive the vehicle to a suitable cleaning place.
2. Unlock the transport protection device.
3. Lower the sweeping unit with the joystick **Fig. 8-74** and drain off the circulating water.
Optionally with circulating water drain, see page 146.

6.1.5 Technical data



Fig. 166:

Complete vehicle with vacuum sweeping system (sweeping unit 2-brush system)

Dimensions	Unit	
Length	mm	4510
Width	mm	1580 to 2250
Height	mm	2215
Sweeping width	mm	1580 to 2250
Turning circle of sweeper	mm	5850
Weights and loads	Unit	
Empty weight according to StVZO	kg	2570
Dirt hopper payload	kg	1000
Sweeping unit/dirt hopper	Unit	
Brush diameter	mm	900
Brush speed	rpm	0 to 120
Dirt hopper nominal volume	litre	1350
Circulating water system settling tank	litre	80
Fresh water tank capacity	litre	188

Complete vehicle with vacuum sweeping system (sweeping unit 3-brush system)

Dimensions	Unit	
Length	mm	5170
Width	mm	1248
Height	mm	2215
Sweeping width	mm	2350
Turning circle of sweeper	mm	8046
Weights and loads	Unit	
Empty weight according to StVZO	kg	2690
Sweeping unit	Unit	
Brush diameter pulled rotating brushes	mm	720
Brush diameter of 3rd rotating brush		900
Brush speed pulled rotating brushes	rpm	30 to 140
Brush speed of 3rd rotating brush		30 to 120


Noise emission values	Unit	Value
Sound pressure level		
The sound pressure level at the workplace (LpA) measured under the customary conditions of use at 1600 rpm according to Directive 2006/42/EC with measuring standard DIN EN ISO 11201 is: <ul style="list-style-type: none"> at 30% suction fan power (measuring uncertainty KpA) 	dB(A)	72 (2.0)
The sound pressure level at the workplace (LpA) measured under the customary conditions of use at 2000 rpm according to Directive 2006/42/EC with measuring standard DIN EN ISO 11201 is: <ul style="list-style-type: none"> at 30% suction fan power (measuring uncertainty KpA) at 100% suction fan power (measuring uncertainty KpA) 	dB(A) dB(A)	71 (2.0) 74 (2.0)
The sound pressure level at the workplace (LpA) measured under the customary conditions of use at 2400 rpm according to Directive 2006/42/EC with measuring standard DIN EN ISO 11201 is: <ul style="list-style-type: none"> at 30% suction fan power (measuring uncertainty KpA) at 100% suction fan power (measuring uncertainty KpA) 	dB(A) dB(A)	75 (2.0) 76 (2.0)
Sound power level		
The sound power level (LWAd) measured under the customary conditions of use at 1600 rpm according to Directive 2000/14/EC with measuring standard DIN EN ISO 3744 is: <ul style="list-style-type: none"> in the ECO mode at 30% suction fan power 	dB(A)	100
The sound power level (LWAd) measured under the customary conditions of use at 2000 rpm according to Directive 2000/14/EC with measuring standard DIN EN ISO 3744 is: <ul style="list-style-type: none"> at 30% suction fan power at 100% suction fan power 	dB(A) dB(A)	101 106
The sound power level (LWAd) measured under the customary conditions of use at 2400 rpm according to Directive 2000/14/EC with measuring standard DIN EN ISO 3744 is: <ul style="list-style-type: none"> at 30% suction fan power at 100% suction fan power 	dB(A) dB(A)	104 106
Vibration values	Unit	Value
The weighted effective value of the acceleration to which the body (feet or seat surface) is subjected to according to directive 2006/42/EC with measuring standard DIN/EN ISO 5349-1 is under the customary conditions of use no more than:	m/s ²	<2.5
The weighted effective value of the acceleration to which the upper limbs (hand-arm) are subjected to according to directive 2006/42/EC with measuring standard DIN/EN ISO 2631-1 is under the customary conditions of use no more than:	m/s ²	<0.5

6.1.6 Maintenance

Maintenance plan for vacuum sweeping system

Maintenance plan – daily
<p>Sweeping unit</p> <ul style="list-style-type: none"> • Checking wear and damage of the sweeping unit • Checking the sweeping level, adjusting if necessary • Fresh water system: checking the spray nozzles, spray nozzle filter and sieve filter, cleaning if necessary
Maintenance plan – weekly
<p>Sweeping unit</p> <ul style="list-style-type: none"> • Checking wear and damage of the sweeping unit • Checking the sweeping level, adjusting if necessary • Fresh water system: checking the spray nozzles, spray nozzle filter and sieve filter, cleaning if necessary <p>Suction mouth and suction duct</p> <ul style="list-style-type: none"> • Checking wear and damage at the suction mouth • Checking the suction mouth setting, adjusting if necessary • Checking the suction hose for wear and seating • Checking the seal between suction duct and dirt hopper • Checking the coarse material flap on the suction mouth <p>Dirt hopper</p> <ul style="list-style-type: none"> • Checking the circulating water system incl. settling tank • Checking the dirt hopper for soiling • Checking the impact plate for wear and damage, changing if required <p>Lubrication service on the vacuum sweeping system (see page 165)</p> <ul style="list-style-type: none"> • Sweeping unit brush arm rotating joint left/right (4 pcs.) • Sweeping unit swivelling cylinder left/right (4 pcs.) • Dirt hopper lifting cylinder up/down and left/right (4 pcs.) • Dirt hopper raising joint left/right (2 pcs.)

Maintenance work

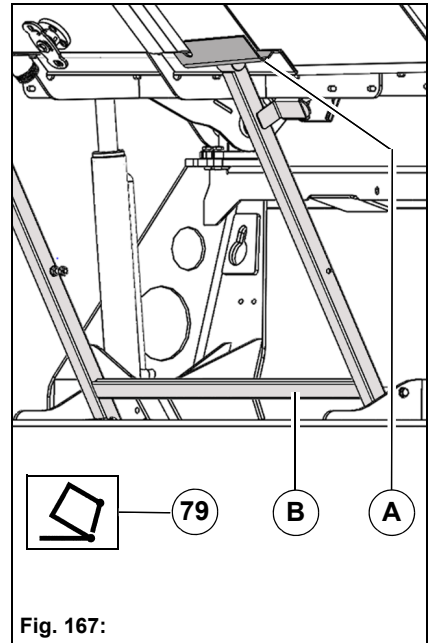
	<p>Danger</p> <ul style="list-style-type: none"> • Always bring and insert the safety strut Fig. 167-B of the dirt hopper into the upper position during maintenance and cleaning work under the raised dirt hopper. There is a risk of injury! • Staying in the danger area is forbidden when raising and lowering the dirt hopper! There is a risk of injury! <p>Attention</p> <ul style="list-style-type: none"> • At temperatures below 0 degrees (risk of frost) drain the water out from all water-conducting components.
---	---

Inserting the safety strut

Raise the emptied dirt hopper with the button **Fig. 167-79** up into its end position.

Hinge over the safety strut **Fig. 167-B**.

Lower the dirt hopper with the button **Fig. 167-79** and insert the safety strut in the recess **Fig. 167-A**.



Checking the rotating brushes

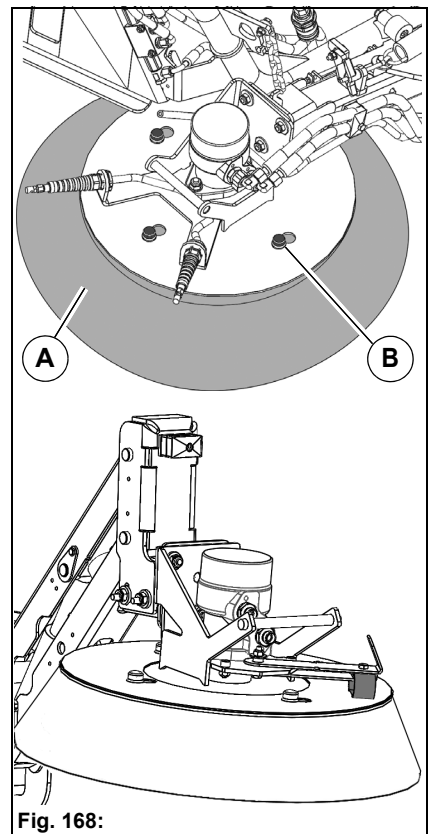
Check the rotating brushes **Fig. 168-A** daily. Adjust the rotating brush pressure as required, see page 162. If the rotating brush pressure is changed, the sweeping level must be reset, see page 163.

Change worn out rotating brushes.

To do this, raise the sweeping unit with the joystick **Fig. 172-74**. Remove the caps **Fig. 168-B** and loosen the nuts located below. Turn the rotating brush counter-clockwise and push it downwards.

Checking the trailing rubber strap (3rd rotating brush)

Check the trailing rubber strap **Fig. 168-C** every 500 operating hours. If required, replace the trailing rubber strap.



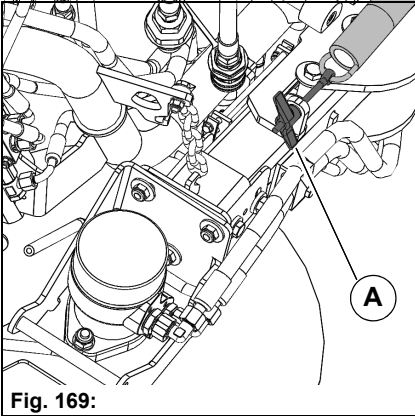


Fig. 169:

Checking the rotating brush pressure

Adjust the rotating brush pressure with the adjusting screw **Fig. 169-A**. The sweeping level must be adjusted with increasing wear.

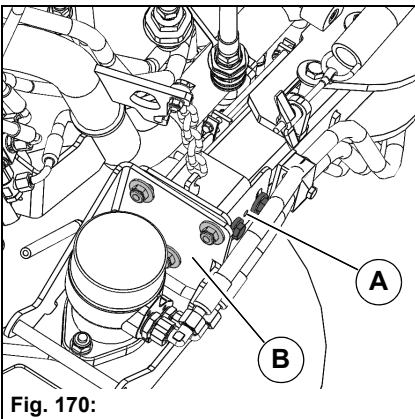


Fig. 170:

Checking the sweeping level (sweeping unit 2-brush system)

The sweeping level **Fig. 171-A** is adjusted in the factory with the screws **Fig. 170-A** and **Fig. 170-B**.

1. Raise the front sweeping machine with the joystick **Fig. 171-74**.
2. Drive over a level surface covered with dust or chalk.
3. Lower the sweeping unit and let the rotating brushes turn for a short time.
4. With correctly adjusted sweeping level, the following pattern must result in driving direction:
 - Right rotating brush from 10 a.m. to 4 p.m.
 - Left rotating brush from 8 a.m. to 2 p.m.

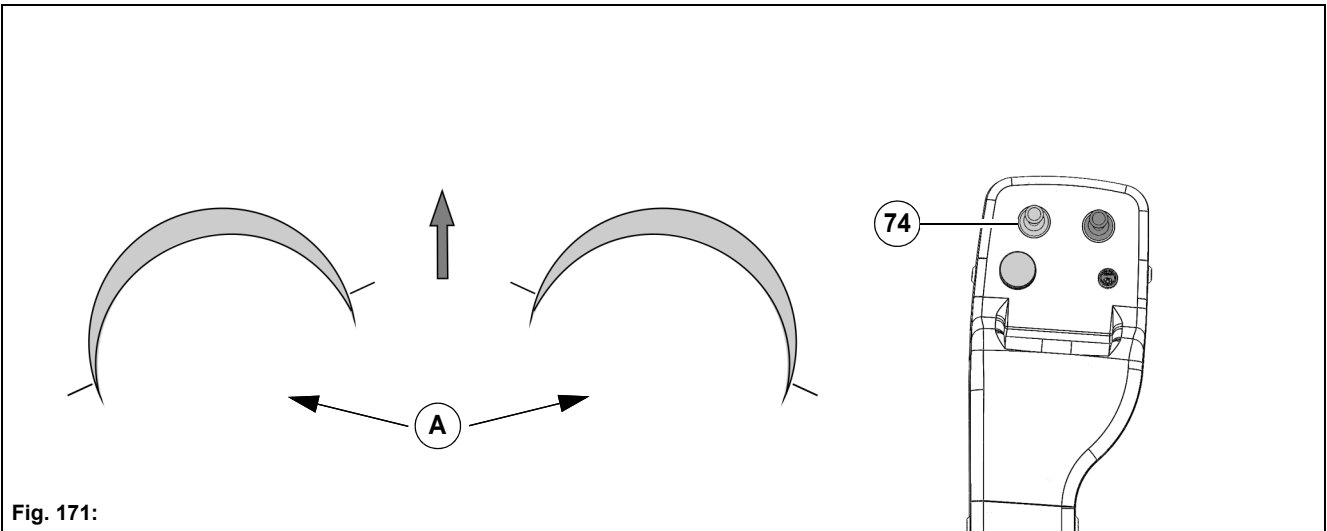


Fig. 171:

Checking the sweeping level (sweeping unit 3-brush system)

The sweeping level **Fig. 172-A** and **Fig. 172-B** for the pulled rotating brushes is adjusted in the factory with the screws **Fig. 172-D** and **Fig. 172-E**.

The sweeping level **Fig. 172-C** for the 3rd rotating brush is set in the factory using the screws **Fig. 172-F**.

1. Raise the sweeping unit with the joystick **Fig. 172-74** and **Fig. 172-75**.
2. Drive over a level surface covered with dust or chalk.
3. Lower the sweeping unit and let the rotating brushes turn for a short time.
4. With correctly adjusted sweeping level, the following pattern must result in driving direction:
 - Pulled rotating brushes:
 - Left rotating brush **Fig. 172-A** from 10 a.m. to 4 p.m.
 - Right rotating brush **Fig. 172-B** from 8 a.m. to 2 p.m.
 - 3rd rotating brush **Fig. 172-C**:
 - From 10 a.m. to 4 p.m.

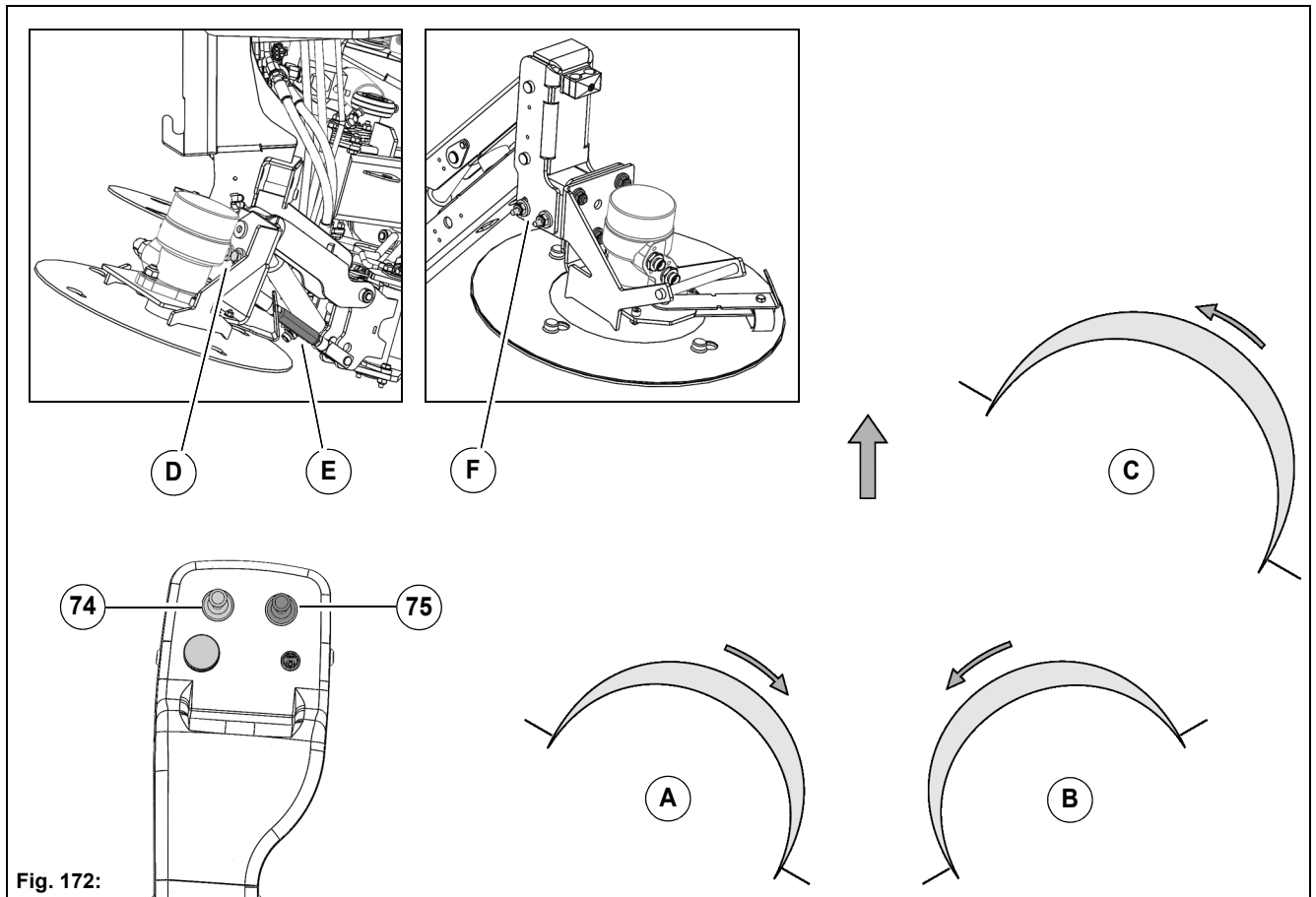


Fig. 172:

Checking the suction mouth sealing strips

Check the sealing strips **Fig. 173-A** of the suction mouth daily. Immediately replace defective seals, also on the coarse material flap, since the suction power is reduced.

The gap **Fig. 173-B1** between the side sealing strip and ground must be approx. 5 mm.

The gap **Fig. 173-B2** between the rear sealing strip and ground must be approx. 10-15 mm.

In the case of wear of the sealing strips, fasten the rollers **Fig. 173-C** in the next higher hole **Fig. 173-D**.

Make sure that the gap size is maintained!

Make sure that the rollers are again fastened in the lower hole after the sealing strips have been changed!

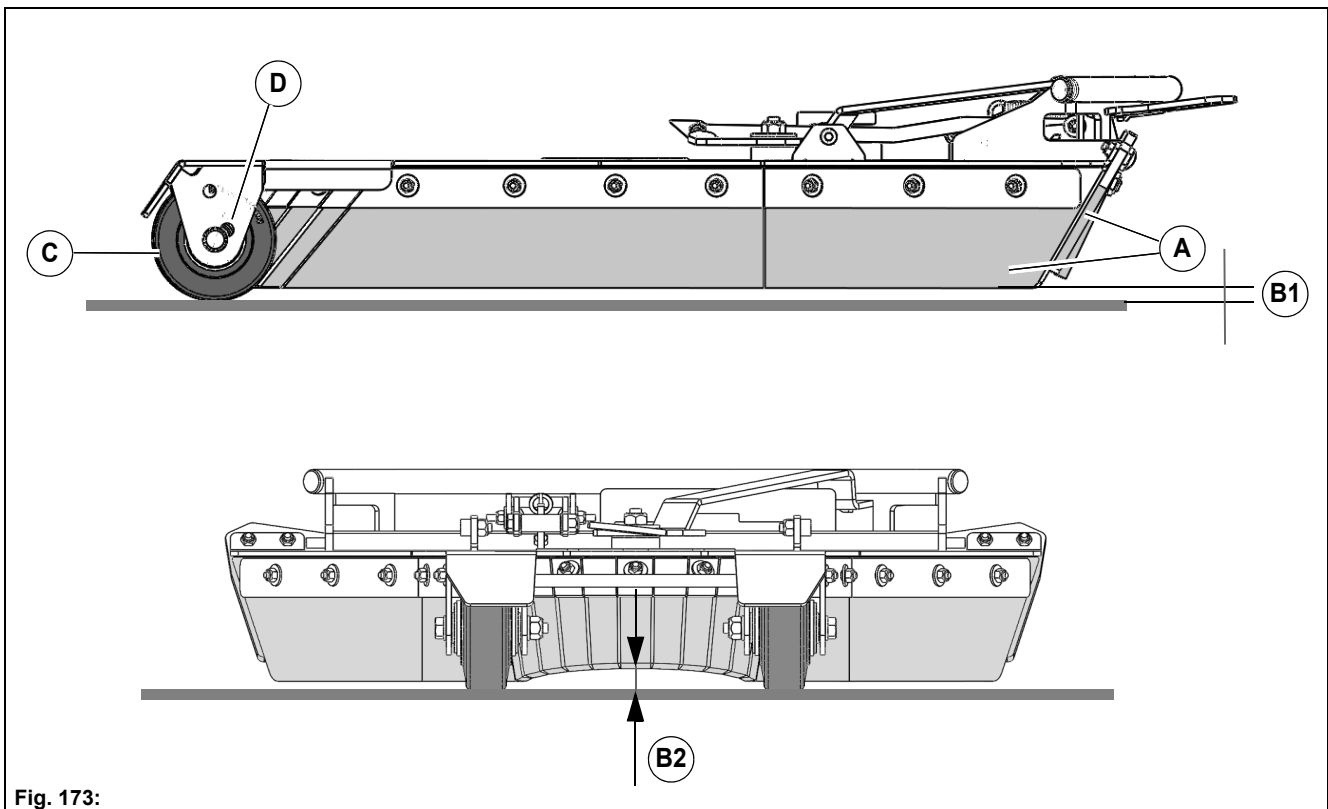


Fig. 173:

Checking the suction duct seal

Check the suction duct seal **Fig. 174-A** on the dirt hopper daily. Immediately replace a defective suction duct seal, since the suction power is reduced. To do this, loosen the clamping band **Fig. 174-B**.

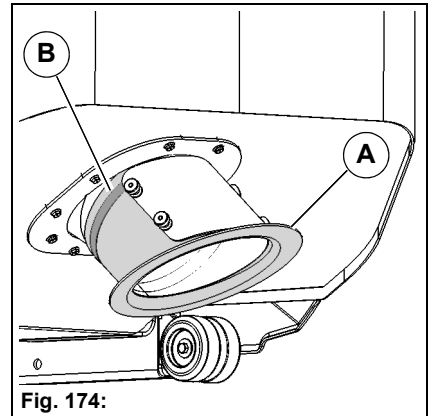


Fig. 174:

Lubrication points (sweeping unit 2-brush system)

Check the lubrication points weekly.

Grease: Mobilgrease MP

- Sweeping unit brush arm rotating joint left/right (x4) **Fig. 175-A**
- Sweeping unit swivelling cylinder left/right (x4) **Fig. 175-B**
- Swivelling unit right-hand brush (x2) (optional) **Fig. 175-C**
- Single-point lubrication system sweeping unit (x1) (optional) **Fig. 175-D**

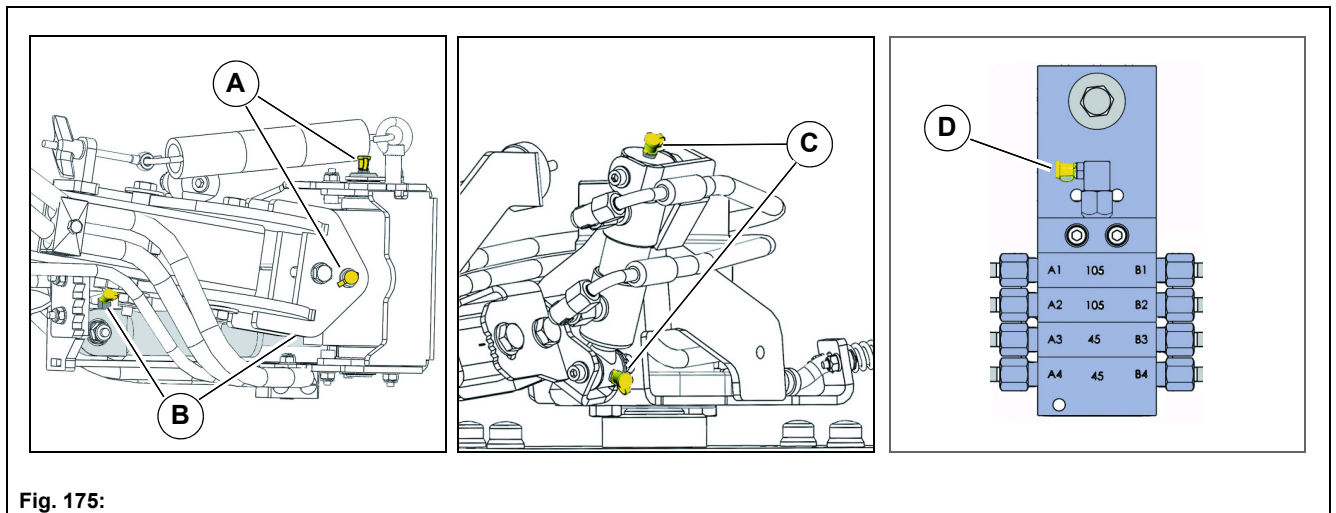


Fig. 175:

Lubrication points (sweeping unit 3-brush system)

Check the lubrication points weekly. Grease: Mobilgrease MP. Pulled rotating brushes in driving direction:

- at the hydraulic cylinders on the left and right **Fig. 176-A** (x4)
 - at the bearing bolts in the left and right panel **Fig. 176-B** (x2)
 - at the hydraulic cylinder for the sweeping width **Fig. 176-C** (x2)
 - at the bearing bolts in the rocker **Fig. 176-D** (x1)
- 3rd rotating brush:

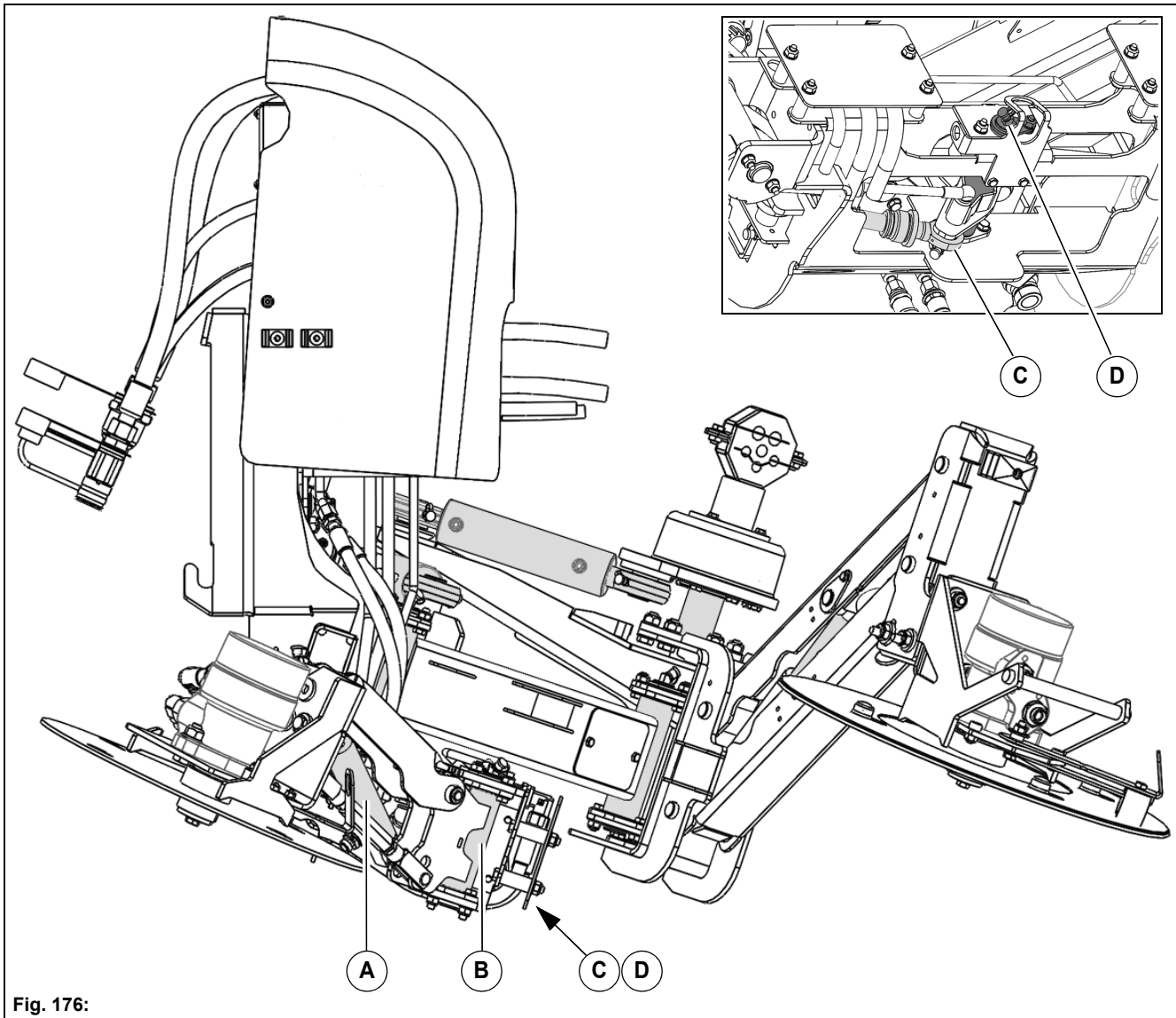


Fig. 176:

Lubrication points sweeping unit (sweeping unit 3-brush system)

– Continuation

Check the lubrication points weekly.

Grease: Mobilgrease MP

- at the hydraulic cylinders of the horizontal arm **Fig. 177-A** (x4)
- at the bearing bolts of the horizontal arm **Fig. 177-B** (x4)
- at the hydraulic cylinder for the vertical arm **Fig. 177-C** (x2)
- at the bearing bolt for the coupling **Fig. 177-D** (x1)
- single-point lubrication system sweeping unit 3-brush system (x1) (optional) **Fig. 177-E**

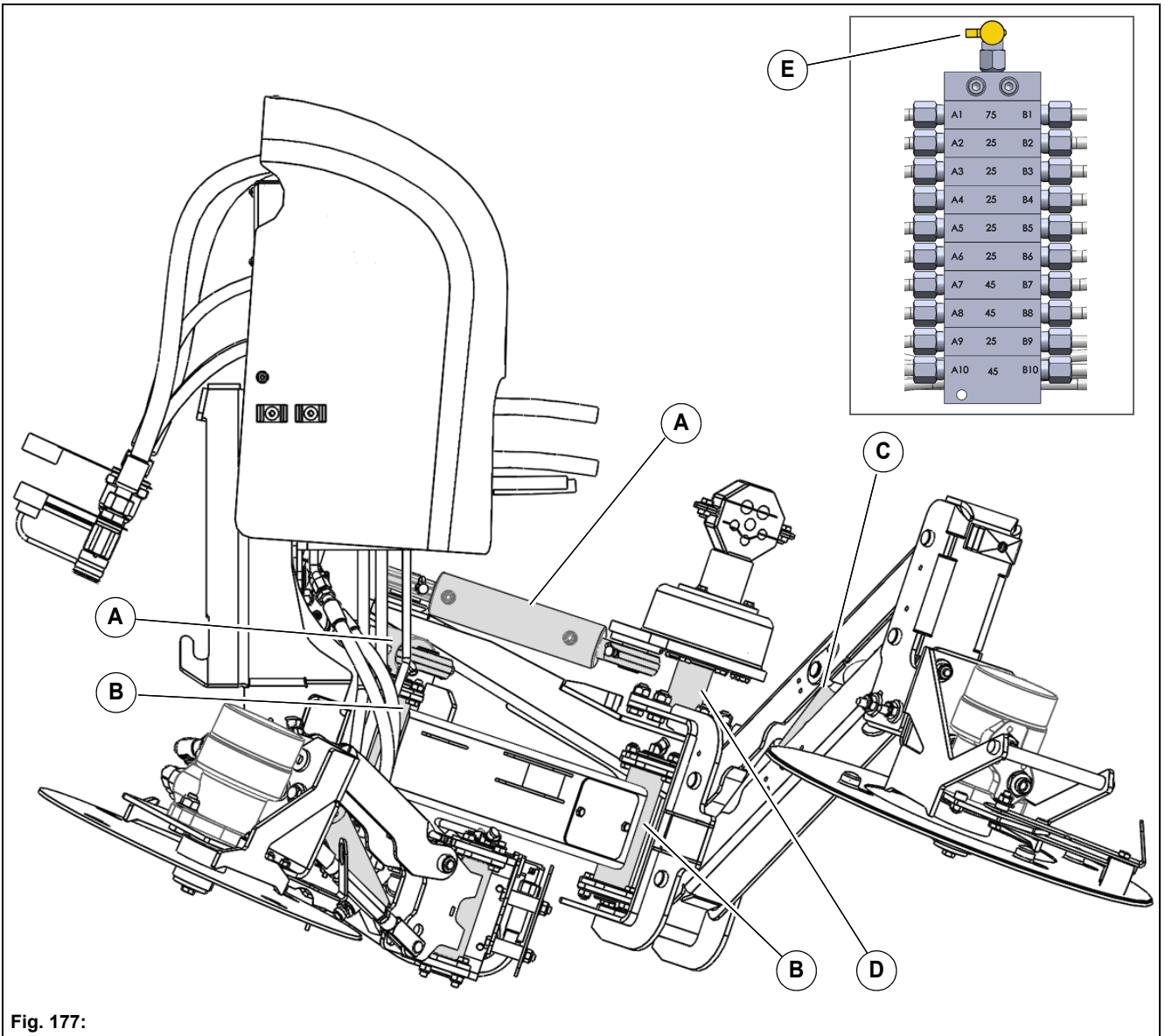


Fig. 177:

Lubrication points dirt hopper

Check the lubrication points weekly.

Grease: Mobilgrease MP

- Dirt hopper lifting cylinder up/down and left/right (x4) **Fig. 178-A**
- Dirt hopper raising joint left/right (x2) **Fig. 178-B**
- Single-point lubrication system dirt hopper (x1) (optional) **Fig. 178-C**

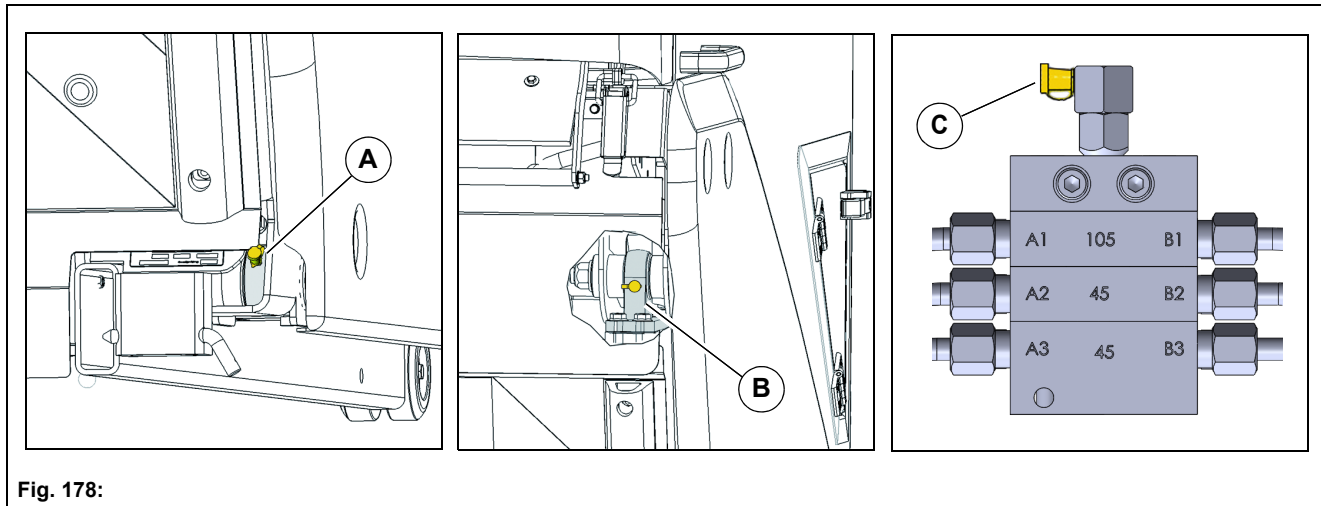


Fig. 178:

6.1.7 Troubleshooting

The fresh water supply is interrupted	Remedy	Reference
The fresh water tank is empty	Fill the fresh water tank according to the indicator	Page 138
The fresh water system is clogged	Cleaning the sieve filter and reducing piece Cleaning the spray nozzles and ball valve filter	Page 155 Page 155
The circulating water supply is interrupted	Remedy	
The circulating water system is empty	Filling the dirt hopper up to the mark	Page 139
The circulating water system is clogged	Flushing the circulating water system with water	Page 156
The sweeping power is reduced	Remedy	Reference
The coarse material flap is still open	Closing the coarse material flap	Page 143
The dirt hopper is full	Emptying the dirt hopper	Page 154
The flap of the dirt hopper is not locked	Locking the dirt hopper	Page 154
The suction fan is contaminated	Cleaning the suction fan	Page 155
The dirt hopper and sieve are contaminated	Cleaning the dirt hopper	Page 156
The circulating water system is contaminated	Cleaning the circulating water system	Page 156
The vacuum system is clogged	Cleaning the suction mouth with the auxiliary tool	Page 155
The suction mouth sealing strips are defective	Checking the suction mouth sealing strips	Page 164
The suction duct seal is defective	Replace the suction duct seal	Page 165
The sweeping level is not adjusted correctly	Adjust the sweeping level	Page 163
The rotating brush pressure is not correctly set	Setting the rotating brush pressure	Page 162
The hand suction hose is not correctly set on	Set the hand suction hose	Optional

6.1.8 Accessories

Your authorised Hako dealer is available to you at any time to answer questions on accessories for the vacuum sweeping system.

6.2 Lawn mowing system

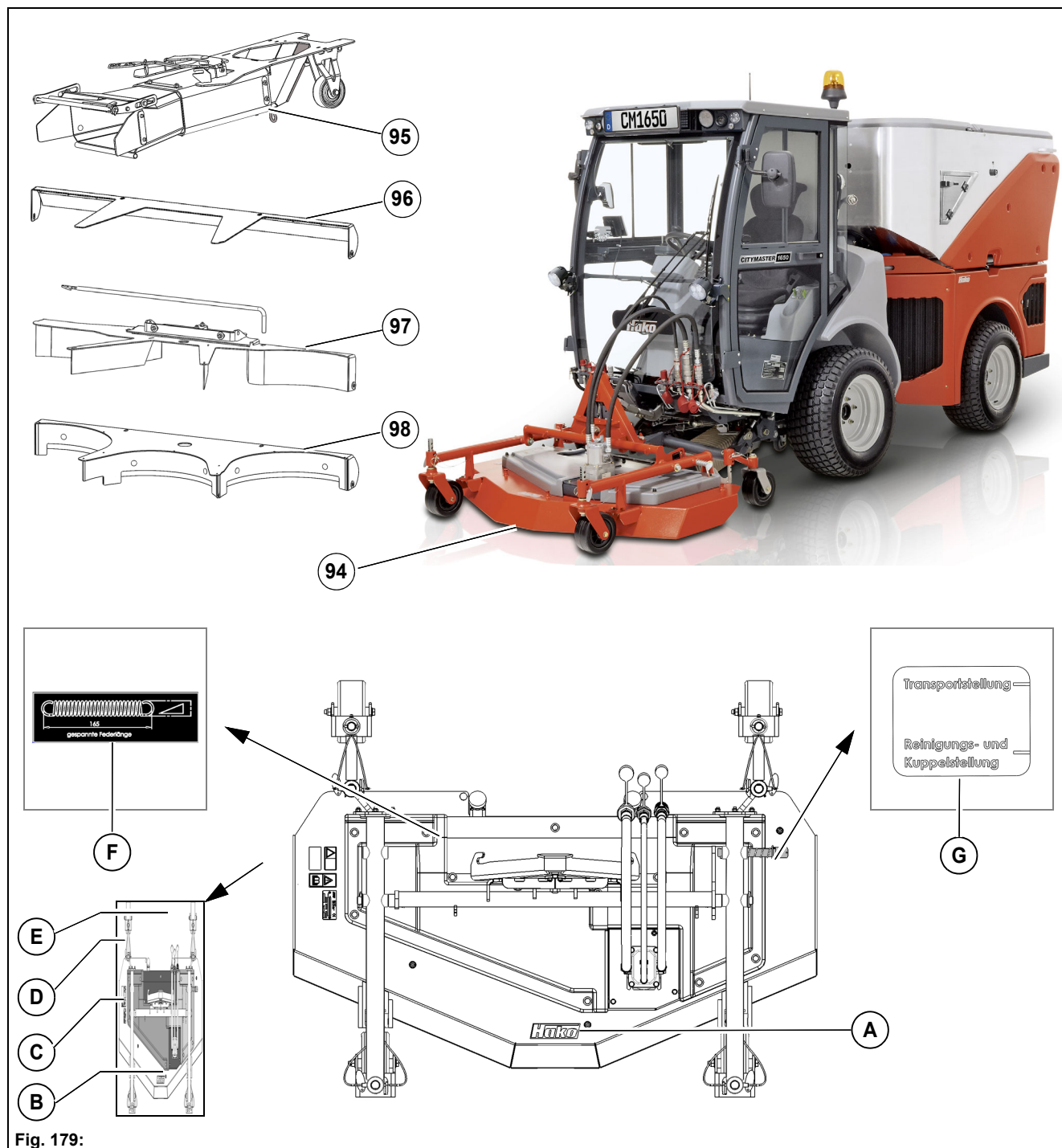


Fig. 179:

Item	Designation
94	Front mower 150 cm
95	Suction nozzles
96	Tail ejector attachment parts
97	Vacuum system attachment parts
98	Mulching attachment parts

6.2.1 Labels on the unit

Hako logo

The Hako logo **Fig. 179-A** is located on the mower cover.

Type plate

The type plate **Fig. 179-B** is located on the right side of the mower.

Label – Read operating manual

The Read operating manual label **Fig. 179-C** is located on the right side of the mower.

Rotating parts label

The Rotating parts label **Fig. 179-D** is located on the right side of the mower.

Keep distance label

The Keep distance label **Fig. 179-E** is located on the right side of the mower.


Spring length label

The Spring length label **Fig. 179-F** is located on the right side of the mower under the cover.

Transport and work position

The Transport and work position label **Fig. 179-G** is located on the left side of the mower under the cover.

6.2.2 Lawn mowing system safety instructions

	<p>Danger</p> <ul style="list-style-type: none"> • Danger to life in the danger area of the vehicle! Special caution is required under the raised tipper and in the area of the front mower. • Risk of injury! Make sure that the attachments are suitable for the set oil volume. An oil volume set too high can lead to injuries due to a defect of the attachment! • Risk of injury! Always wear protective gloves when changing blades! • Risk of injury! Immediately renew damaged or highly unbalanced mowing blades to avoid damage to the blade bearings. • Risk of injury! Before reinstalling, balance the blades and check them for out of true in height. • Risk of injury! The V-belt is self-tensioning by spring force. Do not hook tension springs in or out with your bare hand. • Risk of injury! Do not exceed the permissible total weight. There is a risk of accidents! Frequently check the filling level of the dirt hopper. Switch the suction fan off for this! The lid of the dirt hopper must not be opened when the suction fan is running. • Risk of injury! Modifying the safety equipment is not permitted! • Risk of accident! You must consult Hako before attaching other attachments not approved by Hako! <p>Warning</p> <ul style="list-style-type: none"> • The lawn mowing system may be put into operation only with the suction nozzle raised! Refer to mounting the mower on page 172! • The lawn mowing system may be operated only in connection with the Citymaster 1650. The safety regulations for the Citymaster 1650 must be complied with absolutely. <p>Caution</p> <ul style="list-style-type: none"> • The labels attached to the vehicle provide important information for safe operation. Renew labels that are no longer legible or present. • Spare parts must be original spare parts to guarantee safety.
--	---

6.2.3 Mounting

Mounting the mower

1. Place the vehicle on a level surface and hold it with the parking brake.
2. Fit the suction nozzle **Fig. 180-96**, see page 130.
3. Install the vacuum system **Fig. 180-95** on the lawn mower **Fig. 180-94**. Make sure that the blade can move easily! Adjust with washer as required.
4. Unlock the locking hook **Fig. 180-A** and locking rod **Fig. 180-B** on the front tool carrier. The mower must be mounted in the coupling position **X**!
5. Align the mower **Fig. 180-94** centrally and in alignment with the front tool carrier.
6. Raise the front tool carrier **Fig. 180-12** with the joystick **Fig. 180-74** and hook the chain **Fig. 180-C** on the hook **Fig. 180-D**.
7. Take up the mower and lock the locking hook and locking rod.
8. Close the valve **Fig. 180-E** for raising the suction mouth in the raised position!
9. Lock the suction nozzle **Fig. 180-96** at the suction system with the bow **Fig. 180-F**.
10. Make the connections.
 - Max. 50 litres/min. – Supply/return (hydraulic circuit I) = **Fig. 180-G**
 - Leakage oil pipe = **Fig. 180-H**

Dismantling is in the reverse order.

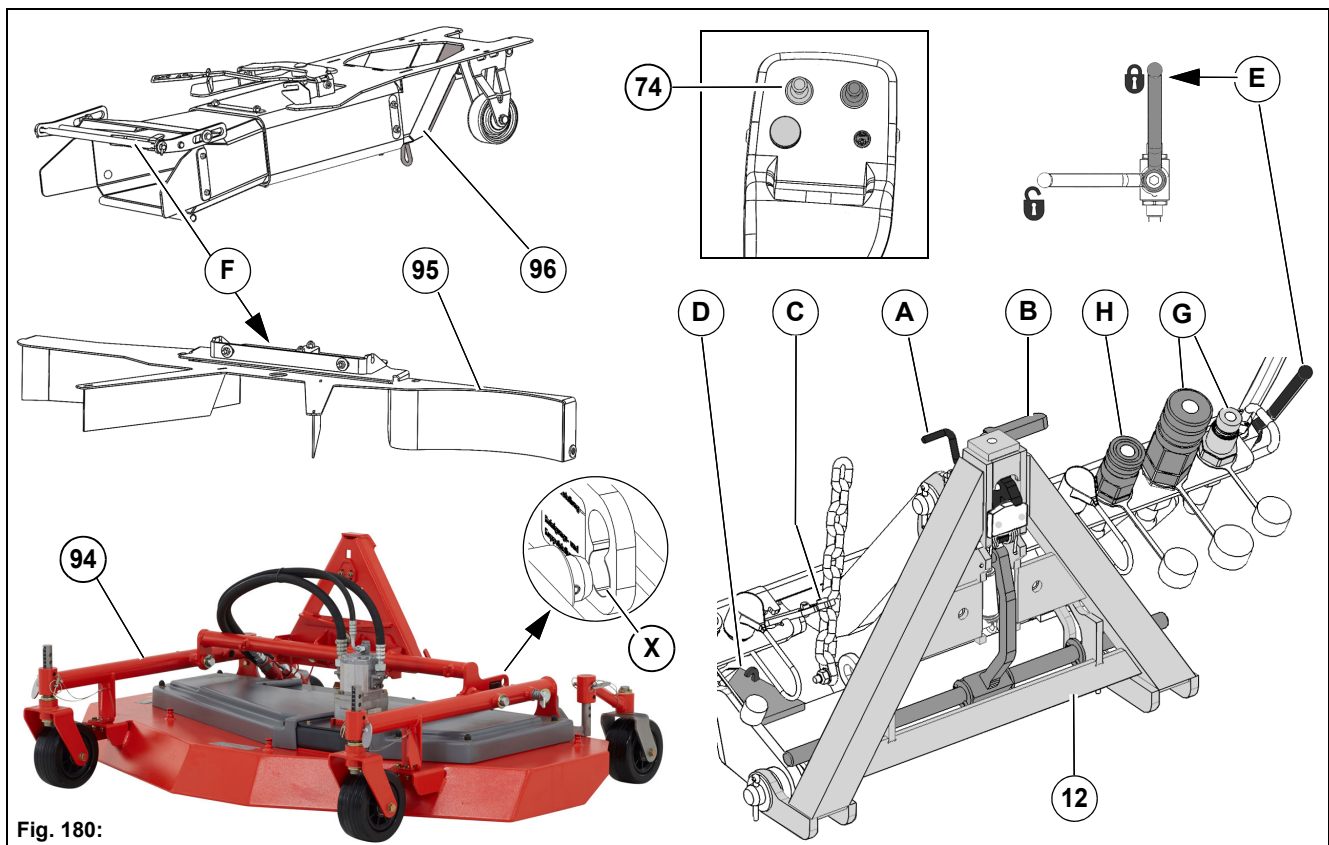


Fig. 180:

6.2.4 Operation

Checklist – Before start-up of the mowing system

No.	Description	Reference
1	Checking the transport protection device	Page 173
2	Adjusting the cutting height	Page 173
3	Preparing the dirt hopper	Page 173
4	Checking and if necessary changing the mowing blades and V-belt	Page 179

Checking the transport protection device

The transport protection device is located on the left side of the mower. The mower is set for the relevant operation with the mounting bolt

Fig. 181-A. The following settings are possible:

- Mowing: take the mounting bolt out from the mounting position, see the illustration (the mower must float freely).
- Transport: the mounting bolt must secure the mower in the upper position **Fig. 181-B**.
- Cleaning: the mounting bolt must secure the mower in the lower position **Fig. 181-C**.

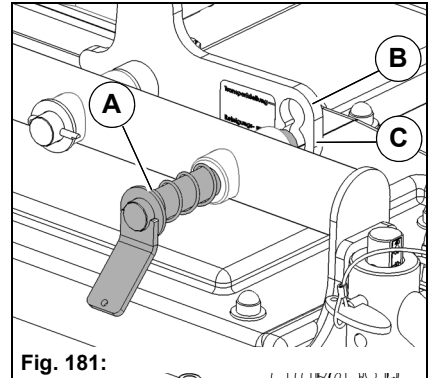


Fig. 181:

Adjusting the cutting height

1. Place the vehicle on a level surface and hold it with the parking brake. Raise the mower with the joystick **Fig. 184-74**. Switch the engine off and pull out the ignition key.
2. Pull the mounting bolt **Fig. 182-C** out and push the bolt **Fig. 182-A** of the wheel fork into the bush **Fig. 182-B** of the wheel spar until the wanted cutting height is set. You can adjust the cutting height centimetre by centimetre with the two mounting holes in the bush.
3. You can read off the cutting height on the scale **Fig. 182-D**.
4. Secure the set cutting height with the mounting bolt.

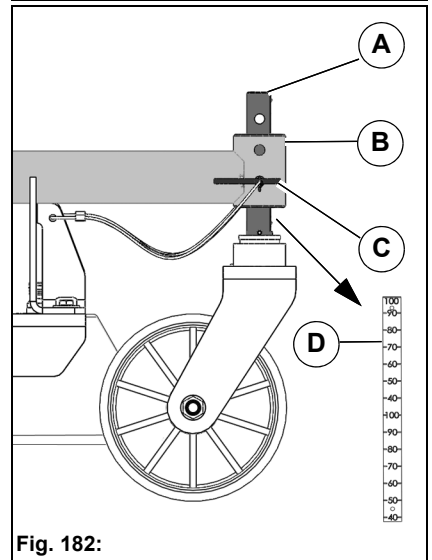


Fig. 182:

	<p>Note</p> <p>The setting of the cutting height must be the same for all wheels.</p> <p>If the grass is very long and wet, you are recommended firstly to cut high and then to cut low once again.</p>
--	--

Preparing the dirt hopper

	<p>Note</p> <p>Mowing without circulating water! Lock the sump valve, see page 156.</p>
--	--

Checklist – Mowing

No.	Description	Reference
1	Driving to the work site	Page 174
2	Switching mowing on	Page 174
3	Setting the fixed engine speed	Page 175
4	Starting mowing	Page 175

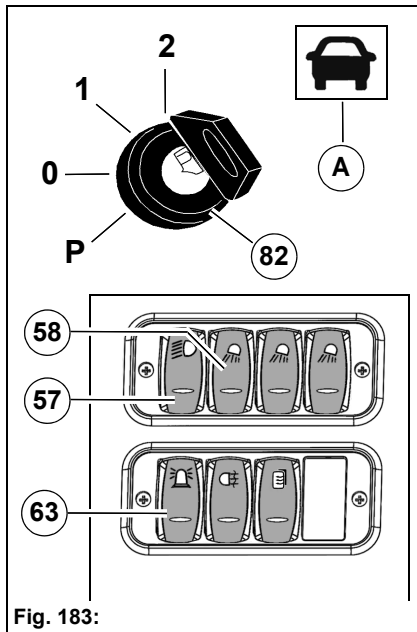


Fig. 183:

Driving to the work site

1. Bring the mower into the transport position, see page 173.
2. Start the vehicle with the ignition switch **Fig. 183-82**.
3. As required, switch on the dipped headlight **Fig. 183-57**, working light **Fig. 183-58** and rotating beacon **Fig. 183-63**.
4. Drive to the work site in the transport mode. The mower must be in the upper end position for the transport mode. Push the joystick **Fig. 184-74** back for this purpose.
5. At the work site bring the mower into its working position, see page 173.

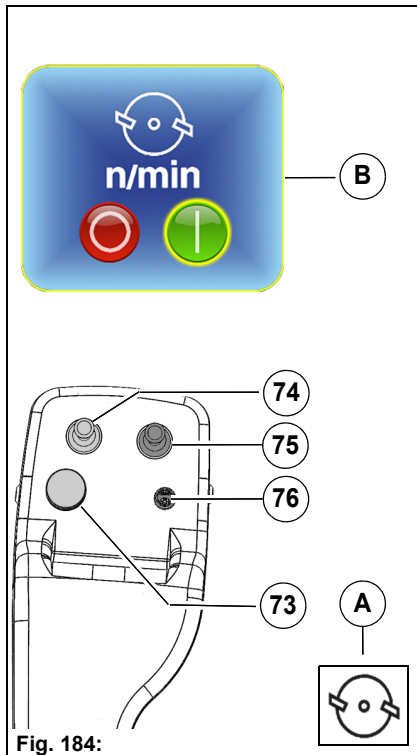


Fig. 184:

Switching the mower on

1. Switch on the work mode with the Hako button **Fig. 184-76**. The accelerator pedals must be in the neutral position. The mower information symbol **Fig. 184-A** appears in the multifunctional display.
2. Use the turn-push knob **Fig. 184-73** in the working menu of the multifunctional display to switch on the mower **Fig. 184-B** and to set relief (optional).
3. Lower the mower with the joystick **Fig. 184-74**. The following functions are activated:
 - The mower is lowered (floating position).
 - Mowing is switched on.

	<p>Note</p> <p>The lowering valve for front lifting (left-hand control panel) must be opened fully for mowing, since otherwise the floating position of the mower is impaired, see page 75!</p>
--	--

Setting the fixed engine speed

The fixed engine speed is set with the tip switch **Fig. 185-67**. Set the speed according to the requirements.

Stage	rpm	Use
1 - ECO	1600	Not suitable for mowing
2 - Standard	2000	For medium load
3 - Maximum	2400	For high load

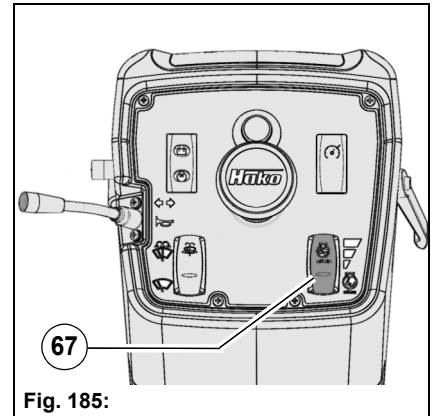


Fig. 185:

Starting mowing

The accelerator pedal **Fig. 186-38** is used for continuously changing the speed for driving forwards.

The accelerator pedal **Fig. 186-39** is used for continuously changing the speed for reversing.

Push the accelerator pedal down slowly until the vehicle starts, the speed is increased further by pressing on the pedal.

Slowing down or braking the vehicle: slowly reduce the pressure on the accelerator pedal, the vehicle slows down or stops.

The vehicle speed in the work mode is 16/20/27 km/h according to the selected engine speed.

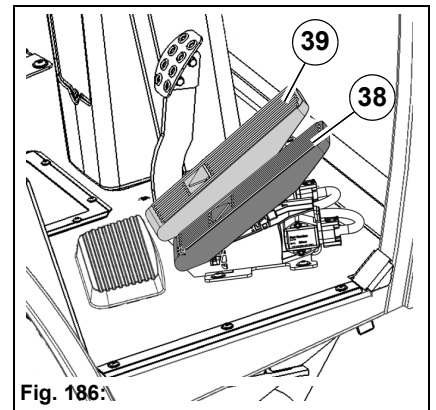


Fig. 186:

	<p>Attention Before you leave the vehicle, the attachment must be lowered to the ground!</p>
--	---

Checklist – Cleaning the lawn mowing system

No.	Description	Reference
1	Emptying the dirt hopper	Page 154
2	Cleaning the dirt hopper	Page 156
3	Cleaning the mower and suction nozzle	Page 176

Cleaning the mower and suction nozzle

1. Raise the mower with the joystick **Fig. 188-74**, mount it in the transport position and drive to a suitable cleaning place.
2. Turn the steering wheel as far as possible to the right at the cleaning place. Switch the engine off and pull out the ignition key.
3. With the lance **Fig. 187-A** open the flap **Fig. 187-B** of the suction nozzle and remove the coarse dirt. Lock the flap again with the lance.
4. Switch the vehicle on and switch on the suction fan **Fig. 187-E** in the working menu of the multifunctional display and let it run for one to two minutes.
5. Pull the mounting bolt **Fig. 188-A** out and lower the mower with the joystick.
6. Plug a water hose onto the hose coupling **Fig. 187-B** and let the mower run for one to two minutes.
7. Clean the mower from the outside with a water hose or a high-pressure cleaner.

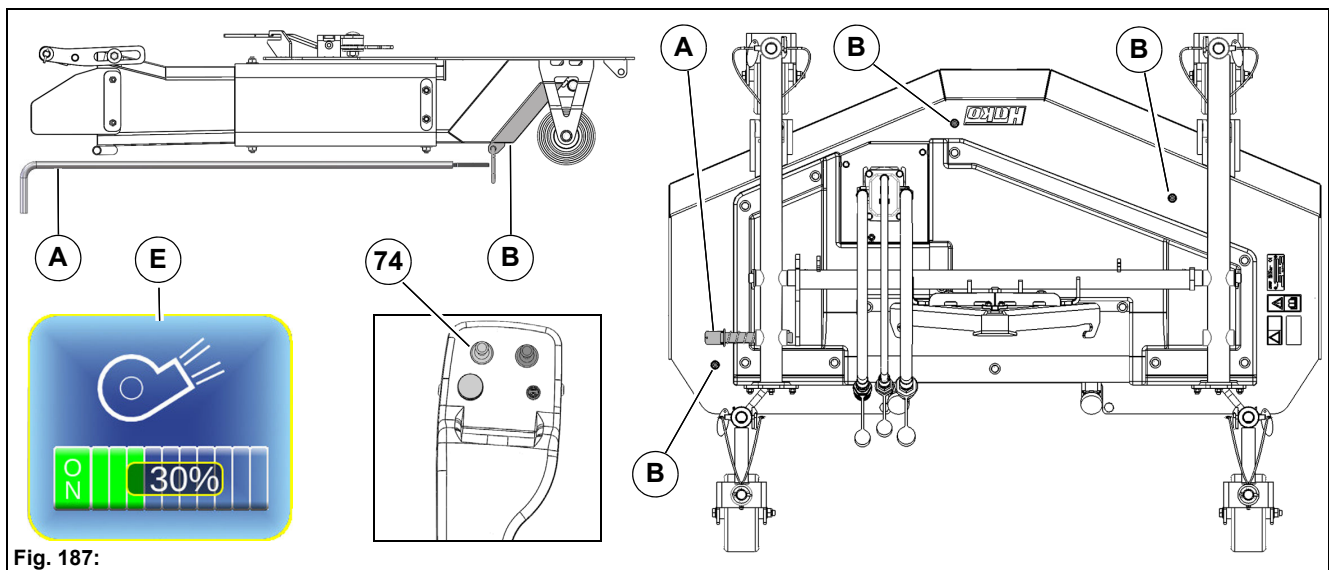


Fig. 187:

6.2.5 Technical data

Front mower	Unit	
Length	mm	980
Width	mm	1540
Height	mm	660
Working width	mm	1500
Weight (mower, vacuum system and suction nozzles)	kg	172
Cutting height in 10 mm steps	mm	40-100
Blade speed	rpm	2594

6.2.6 Maintenance

Maintenance plan

Daily
• Checking wear and damage to the mower
Weekly
• Checking lubrication points

Maintenance work

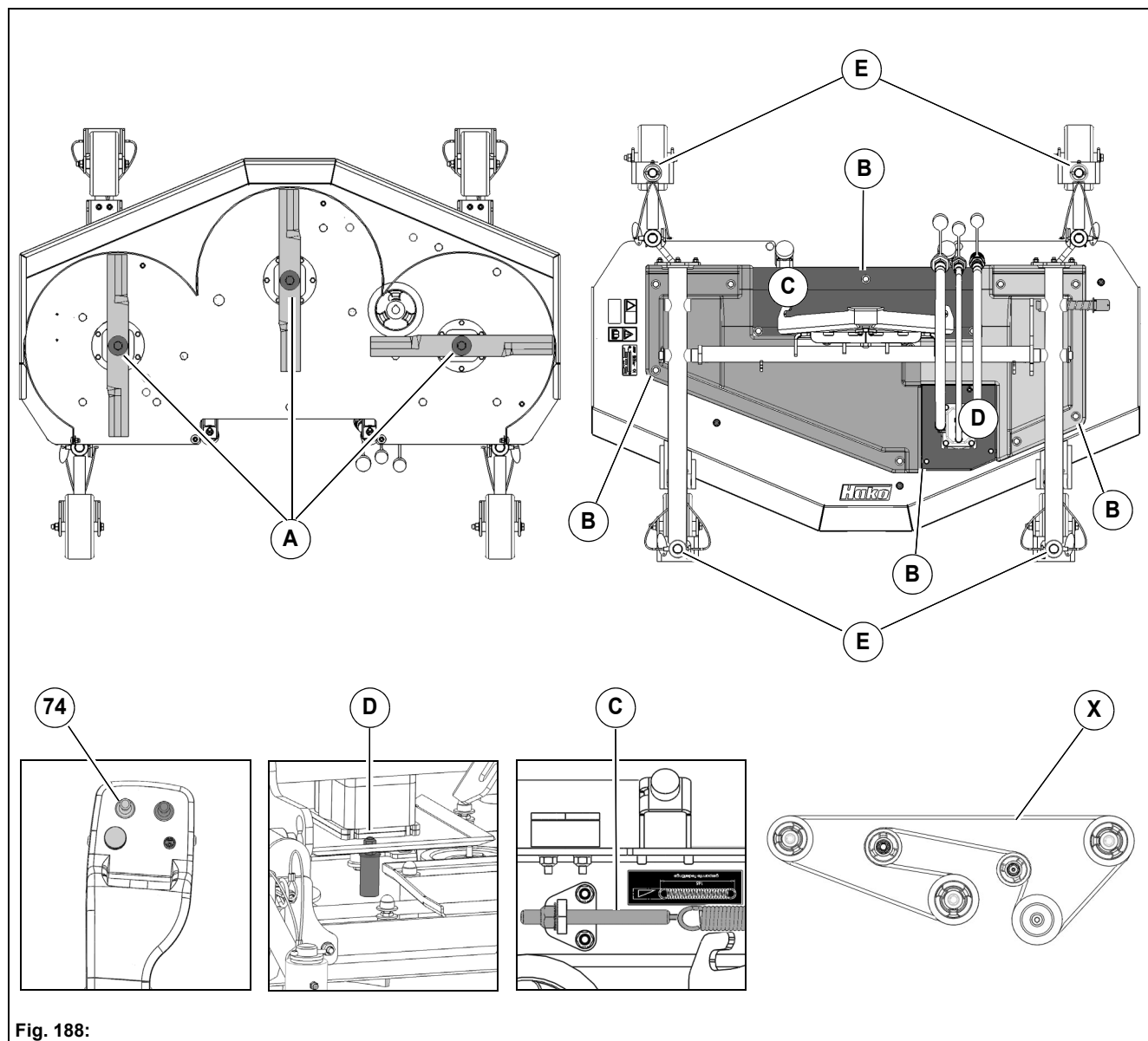


Fig. 188:

Changing mowing blades

1. Place the vehicle on a level surface and hold it with the parking brake. Raise the mower with the joystick **Fig. 188-74**. Switch the engine off and pull out the ignition key.
2. Loosen the screw **Fig. 188-A** and take off the disk and mowing blade.
3. Fit new mowing blade with disk and screw.

**Note**

Tightening torque of the mowing blades: 120 Nm

Changing the V-belt

1. Place the vehicle on a level surface and hold it with the parking brake. Raise the mower with the joystick **Fig. 188-74**. Switch the engine off and pull out the ignition key.
2. Loosen the screws on the covers **Fig. 188-B** and remove the covers.
3. Relax the tension spring with the screw **Fig. 188-C** and unhook it.
4. Remove the screws of the gearbox holder **Fig. 188-D** and remove the defective V-belt.
5. Insert the new V-belt corresponding to **Fig. 188-X**.
6. Fasten the screws on the gearbox holder.
7. Adjust the clamping screw again corresponding to the clamping length of the label (165 mm).
8. Refit the covers correctly.

Lubrication points

Check the lubrication points weekly.

Grease: Mobilgrease MP

- Bushes of the wheel holders **Fig. 188-E** (x4)

6.2.7 Troubleshooting

Grass remains lying	Remedy	Reference
Outlet clogged	Cleaning the mower	Page 179
Suction nozzle clogged	Cleaning the suction pipe	Page 176
Grass too high or wet	Changing the fixed engine speed Changing the cutting height	Page 175 Page 173
Blades blunt	Grinding the blades	Page 179
Blades do not rotate	Remedy	Reference
V-belt defective	Changing the V-belt	Page 179
Ground irregularities are not compensated for	Remedy	Reference
Mounting plug not fitted as specified	Checking the transport protection device	Page 173
Wheels do not turn	Remedy	Reference
Wheels dirty	Cleaning wheels and hubs	Page 179
Mower runs loud and sounds hard	Remedy	Reference
Checking the blade bearings	Balancing the blades	

6.2.8 Accessories

Your authorised Hako dealer is available to you at any time to answer questions on accessories for the lawn mowing system.

6.3 Sweeping system

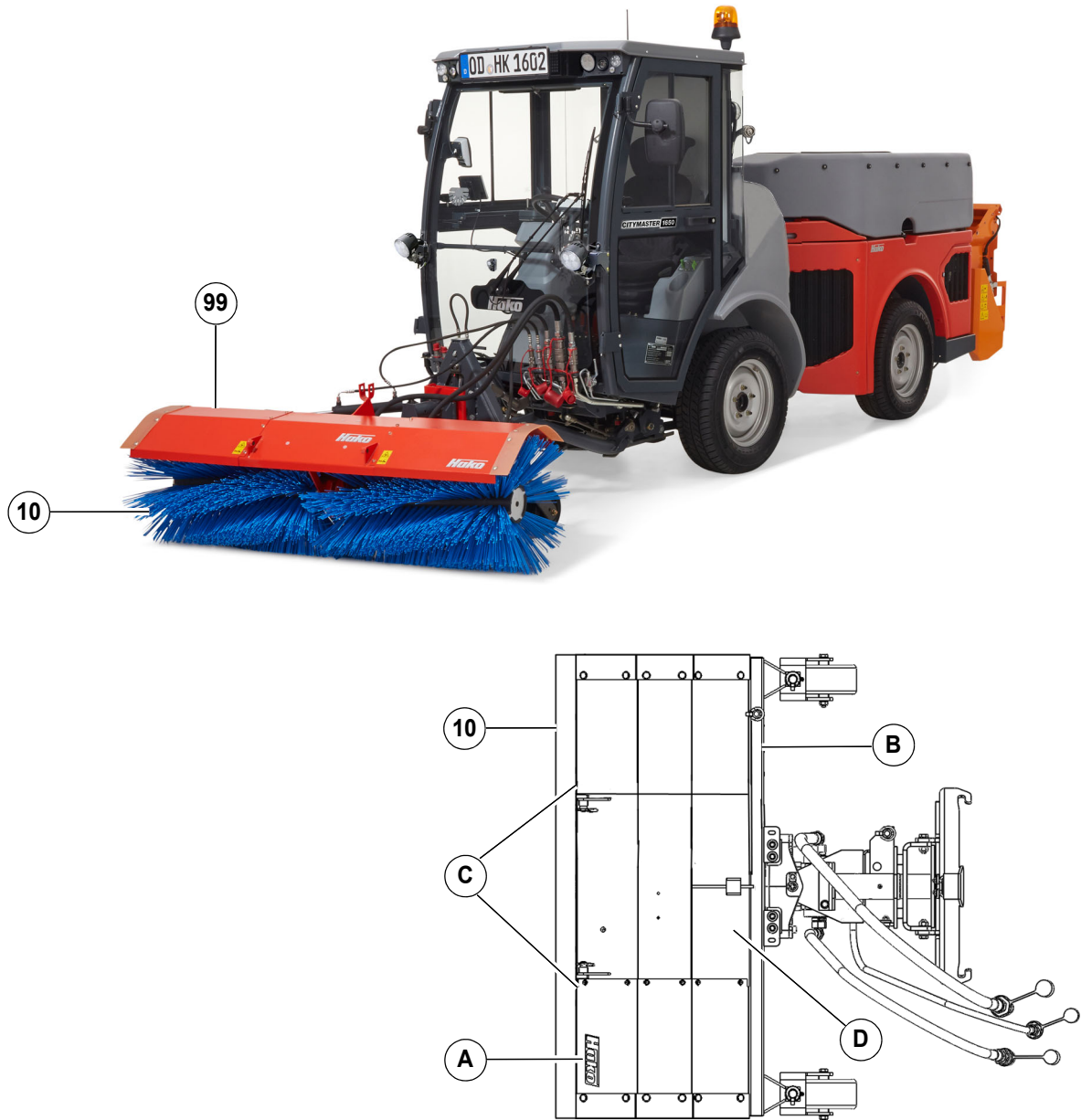


Fig. 189:

Item	Designation
99	Front sweeping machine
100	Cylindrical sweeping roller
101	Spray shield

6.3.1 Labels on the unit

Hako logo

The Hako logo **Fig. 179-A** is located on the right side of the front sweeping machine.

Type plate

The type plate **Fig. 179-B** is located on the left side of the front sweeping machine.


Label – Read operating manual

The Danger of crushing labels **Fig. 179-C** are located on the left and right side of the front sweeping machine.

Label – Read operating manual

The Read operating manual labels **Fig. 179-D** are located on the left and right side of the front sweeping machine.

6.3.2 Sweeping system safety instructions

	<p>Danger</p> <ul style="list-style-type: none">• Danger to life in the danger area of the vehicle! Special caution is required in the area of the articulated steering, under the raised tipper and in the area of the front sweeping roller.• Risk of injury! When sweeping with the front sweeping machine, small stones or other parts in the snow can be thrown out by the rotating sweeping roller.• Risk of injury! Secure the front sweeping machine against rolling away when mounting it. <p>Warning</p> <ul style="list-style-type: none">• The sweeping system may be operated only in connection with the Citymaster 1650. The safety regulations for the Citymaster 1650 must be complied with absolutely. <p>Caution</p> <ul style="list-style-type: none">• The labels attached to the vehicle provide important information for safe operation. Renew labels that are no longer legible or present.• Spare parts must be original spare parts to guarantee safety. <p>Attention</p> <ul style="list-style-type: none">• Thorough and frequent cleaning is especially important after sweeping material containing salt.• Check the secure seating of the sweeping roller before every sweeping operation. <p>Environmental danger</p> <ul style="list-style-type: none">• Ensure safe and environment-conserving disposal of operating and auxiliary materials. Take up escaping or spilled operating materials in suitable containers and dispose of them in an environmentally friendly manner.
---	---

6.3.3 Mounting

Mounting the front sweeping machine

1. Place the vehicle on a level surface and hold it with the parking brake.
2. Unlock the locking hook **Fig. 190-A** and locking rod **Fig. 190-B** on the coupling triangle.
3. Align the front sweeping machine **Fig. 190-99** centrally and in alignment with the coupling triangle.
4. Raise the front tool carrier **Fig. 190-12** with the joystick **Fig. 190-74** and attach the front sweeping machine.
5. Lock the front sweeping machine with locking hook and locking rod.
6. Close the valve **Fig. 190-G** for raising the suction mouth in the raised position!
7. Make the connections.
 - Left actuator – Supply/return = **Fig. 190-E** (optional side adjustment)
 - 19-pin coding plug = **Fig. 190-C**
 - Front sweeping machine hydraulic motors – Supply/return = **Fig. 190-F**
8. Remove the support.

Dismantling is in the reverse order.

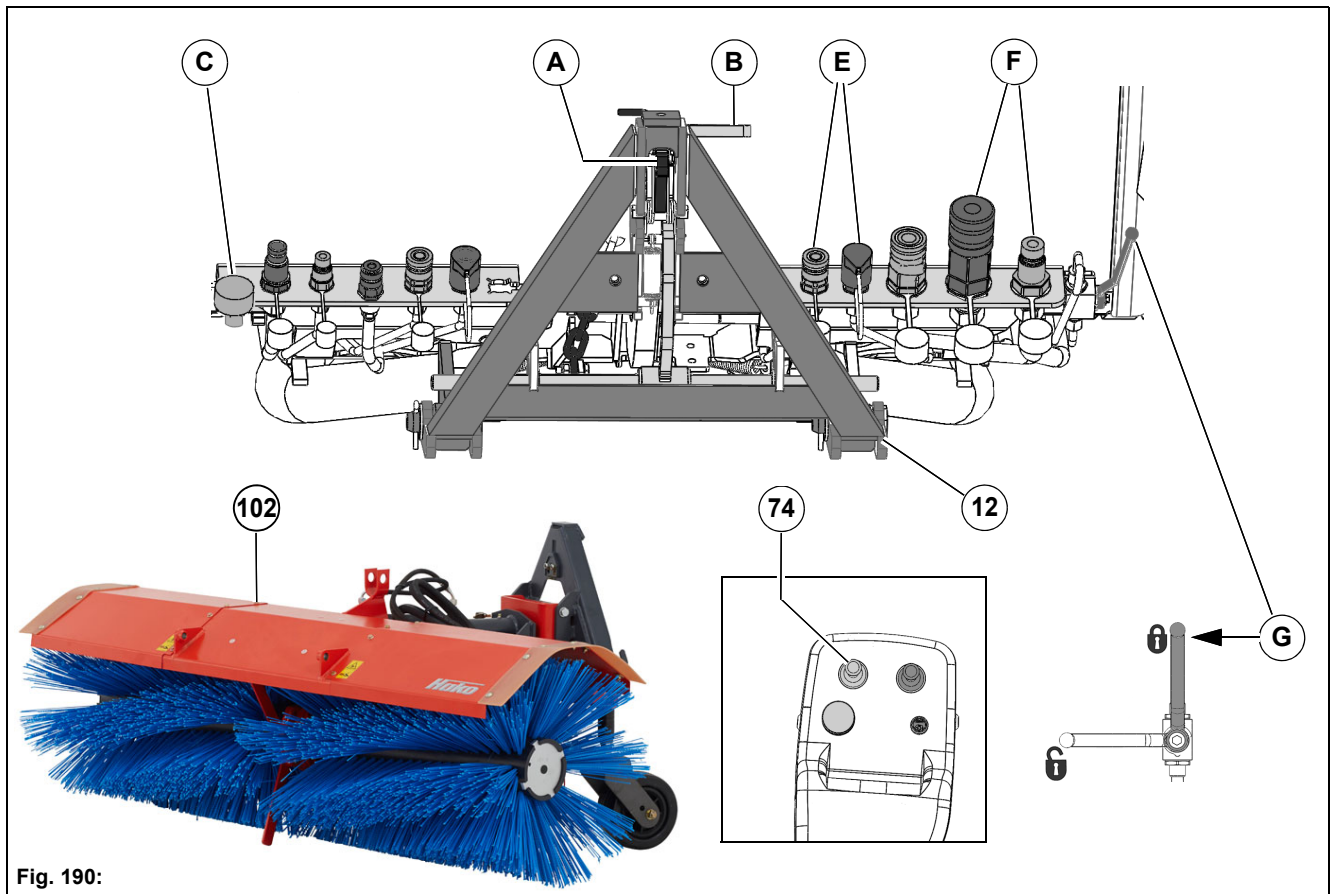


Fig. 190:

6.3.4 Operation

Checklist – Before start-up of the sweeping system

No.	Description	Reference
1	Checking the sweeping level	Page 188
2	Mounting the spray shield for summer operation (optional)	Page 184
3	Adjusting the sweeping direction	Page 184

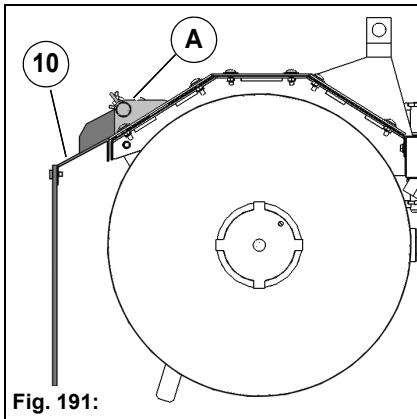


Fig. 191:

Mounting the spray shield for summer operation (optional)

For summer operation set the spray shield **Fig. 191-101** on the holders **Fig. 191-A** of the front sweeping machine and secure with bolts and split-pins.

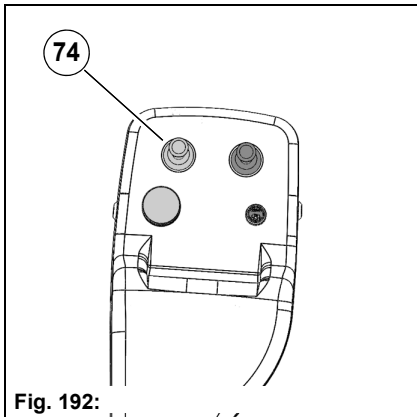


Fig. 192:

Adjusting the sweeping direction

Set the sweeping direction of the front sweeping machine with the joystick **Fig. 192-74**.

- Joystick to the left: the front sweeping machine swivels to the left.
- Joystick to the right: the front sweeping machine swivels to the right.

Checklist – Sweeping

No.	Description	Reference
1	Driving to the work site	Page 185
2	Switching sweeping on	Page 185
3	Setting the fixed engine speed	Page 186
4	Starting sweeping	Page 186

Driving to the work site

1. Bring the front sweeping machine into the transport position, see page 173.
2. Start the vehicle with the ignition switch **Fig. 193-82**.
3. As required, switch on the dipped headlight **Fig. 193-57**, working light **Fig. 193-58** and rotating beacon **Fig. 193-63**.
4. Drive to the work site in the transport mode. The front sweeping machine must be in the upper end position for the transport mode. Push the joystick **Fig. 194-74** back for this purpose.

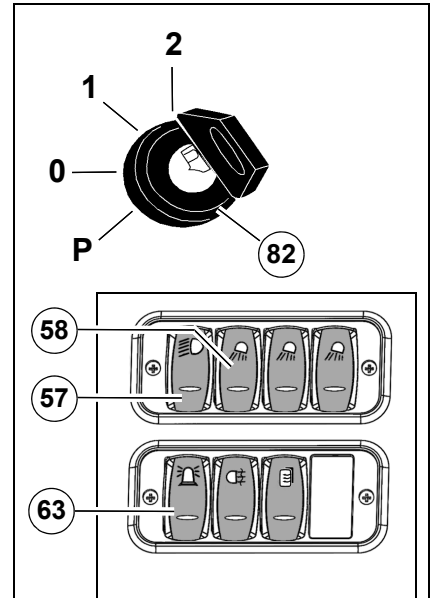



Fig. 193:

Switching sweeping on

1. Switch on the work mode with the Hako button **Fig. 194-76**. The accelerator pedals must be in the neutral position. The front sweeping machine information symbol **Fig. 194-A** appears in the multifunctional display.
2. Use the turn-push knob **Fig. 194-73** in the working menu to switch on the front sweeping machine **Fig. 194-B** and to set the speed.
3. Lower the front sweeping machine with the joystick **Fig. 194-74**. The following functions are activated:
 - The front sweeping machine is lowered (floating position).
 - The sweeping drive is switched on.
 - The sweeping roller speed is activated.

	<p>Note If the front sweeping machine is used for sweeping snow, a spreader can additionally be operated, see page 198.</p>
---	--

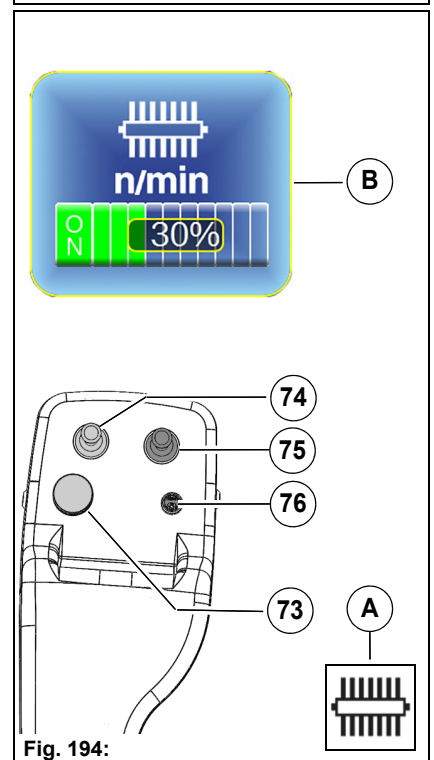


Fig. 194:

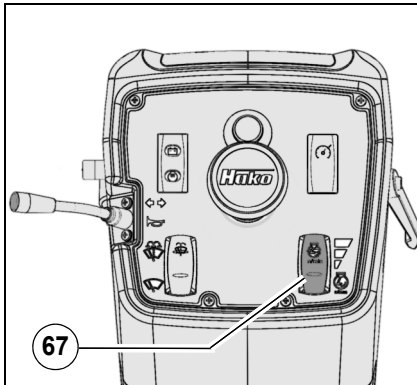


Fig. 195:

Setting the fixed engine speed

The fixed engine speed is set with the tip switch **Fig. 195-67**. Set the speed corresponding to the requirements. The speed must be set so that a centrifuging effect is achieved.

Stage	rpm	Use
1 - ECO	1600	At low load
2 - Standard	2000	For medium load
3 - Maximum	2400	For high load

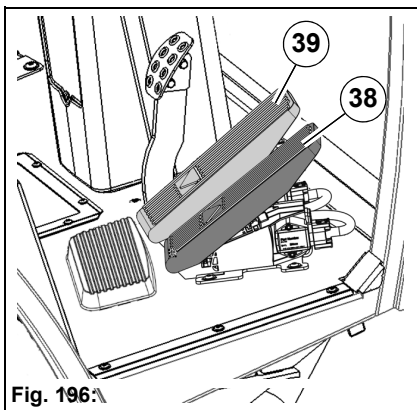


Fig. 196:

Starting sweeping

The accelerator pedal **Fig. 196-38** is used for continuously changing the speed for driving forwards. The accelerator pedal **Fig. 196-39** is used for continuously changing the speed for reversing. Push the accelerator pedal down slowly until the vehicle starts, the speed is increased further by pressing on the pedal. Slowing down or braking the vehicle: slowly reduce the pressure on the accelerator pedal, the vehicle slows down or stops. The vehicle speed in the:

- transport mode is 0 to 40 km/h,
- work mode 16/20/27 km/h according to selected engine speed.

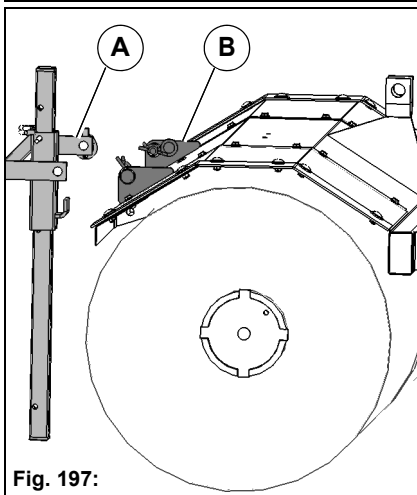


Fig. 197:

Setting down the front sweeping machine

Set the front sweeping machine so that the bristles of the sweeping roller do not touch the ground.

1. Insert the support **Fig. 197-A** (optional) in the front holder **Fig. 197-B**.
2. Secure with bolt and split pin when the required supporting height is reached.

6.3.5 Technical data

Front sweeping machine	Unit	
Length	mm	1050
Width	mm	1600
Height	mm	720
Sweeping width	mm	1600
Weight	kg	147
Sweeping roller diameter	mm	600

6.3.6 Maintenance

Maintenance plan

Daily
<ul style="list-style-type: none"> • Checking wear and damage to the front sweeping machine
Weekly
<ul style="list-style-type: none"> • Checking lubrication points

Maintenance work

Changing the sweeping roller

1. Place the vehicle on a level surface and hold it with the parking brake. Raise the front sweeping machine with the joystick **Fig. 194-74**. Switch the engine off and pull out the ignition key.
 2. The sweeping rollers are fastened to the support tube **Fig. 198-A** with flange **Fig. 198-B**, and crown nut **Fig. 198-C**. Loosen the crown nuts and remove everything.
 3. Mount new sweeping rollers.
- You must readjust the sweeping level after changing the sweeping rollers.

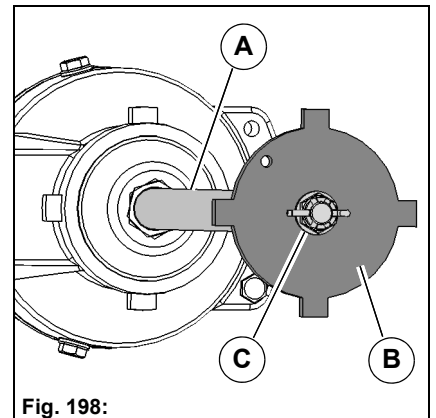


Fig. 198:

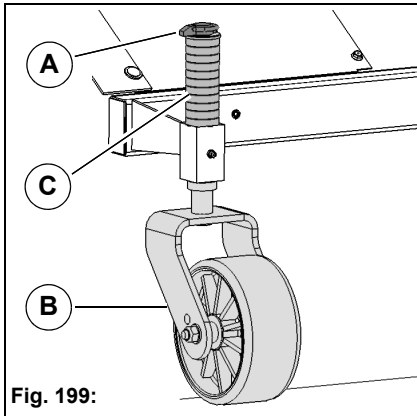


Fig. 199:

Checking the sweeping level

Check the sweeping rollers daily. Change worn sweeping rollers.

1. Place the vehicle on a level surface and hold it with the parking brake. Raise the front sweeping machine with the joystick **Fig. 194-74**. Raise the front sweeping machine with the joystick **Fig. 194-74**.
2. Remove the split-pin **Fig. 199-A** from the bolt of the wheel fork and withdraw the supporting wheels **Fig. 199-B** downwards.
3. Adjust the sweeping level with the washers **Fig. 199-C** on both supporting wheels. For optimum sweeping effect the bristles should press over the ground approx. 20 mm.
4. Reattach the supporting wheels and secure them with split-pins.
5. Check the sweeping level on dust and chalk.

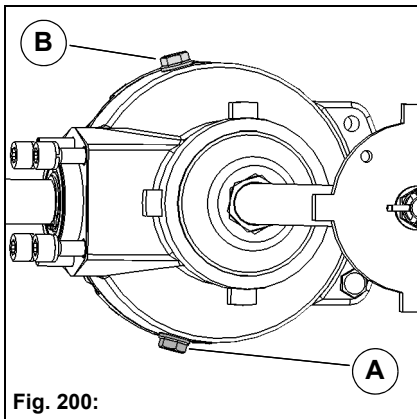


Fig. 200:

Changing the gearbox oil

Check and if necessary top up the oil level in the gearbox. An oil change is necessary after 500 operating hours (at the latest after two years).

1. Place a suitable collecting pan under the drain screw **Fig. 200-A**.
2. Unscrew the drain screw and drain off the gearbox oil completely.
3. Insert the drain screw with new seal.
4. Unscrew the filling screw **Fig. 200-B** and fill with SAE 80W90 gearbox oil. Filling volume = 0.4 litres.
5. Insert the filling screw with new seal.

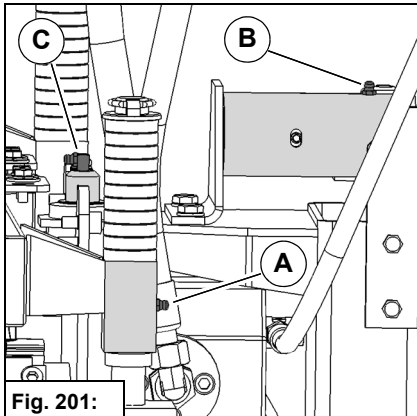


Fig. 201:

Lubrication points

Check the lubrication points weekly.

Grease: Mobilgrease MP

- Left/right supporting wheels (x2) **Fig. 201-A**
- Supporting tube on the coupling triangle (x1) **Fig. 201-B**
- Bearing bolt (x2) **Fig. 201-C**

6.3.7 Troubleshooting

Sweeping performance is bad	Remedy	Reference
Speed of the sweeping roller too low	Increasing the fixed engine speed	Page 186
Sweeping level out of adjustment	Adjusting the sweeping level	Page 188
Sweeping roller worn	Changing the sweeping roller	Page 187

6.3.8 Accessories

Your authorised Hako dealer is available to you at any time to answer questions on accessories for the sweeping system.

6.4 Snow clearing system



Fig. 202:

Item	Designation	Type
102	Folding snow blade 140 cm	576352
103	Hydraulic loading platform	143830
104	Roller spreader	577800

6.4.1 Labels on the unit

Hako logo

A Hako logo **Fig. 202-A** is located on the snow blade, the loading platform and the spreader.


Type plate

A type plate **Fig. 202-B** is located on the snow blade, the loading platform and the spreader.

Label – Read operating manual

The Read operating manual label **Fig. 202-C** is located on the snow blade, the loading platform and the spreader.

6.4.2 Snow clearing system safety instructions

	<p>Danger</p> <ul style="list-style-type: none"> • Danger to life in the danger area of the vehicle! Special caution is required in the area of the articulated steering, under the raised tipper and in the area of the front and rear attachment. • Risk of accident due to unintended lowering of the attachment! Activate winter operation in the configuration menu only in connection with an uncoded snow blade. The front lift is then not limited downwards. Winter operation must be deactivated immediately after use. <p>Warning</p> <ul style="list-style-type: none"> • The snow clearing system may be operated only in connection with the Citymaster 1650. The safety regulations for the Citymaster 1650 must be complied with absolutely. <p>Caution</p> <ul style="list-style-type: none"> • The labels attached to the vehicle provide important information for safe operation. Renew labels that are no longer legible or present. • Spare parts must be original spare parts to guarantee safety. <p>Attention</p> <ul style="list-style-type: none"> • Thorough and frequent cleaning is especially important after sweeping material containing salt.
---	---

6.4.3 Mounting

Mounting the snow blade

1. Place the vehicle on a level surface and hold it with the parking brake. Switch the engine off and pull out the ignition key.
 2. Unlock the locking hook **Fig. 203-A** and locking rod **Fig. 203-B** on the front tool carrier **Fig. 203-12**.
 3. Align the snow blade **Fig. 203-102** centrally and in alignment with the front tool carrier.
 4. Raise the snow blade with the joystick **Fig. 203-74** up into the end position.
 5. Lock the snow blade with the locking hook and locking rod.
 6. Close the valve **Fig. 203-C** for raising the suction mouth in the raised position!
 7. Make the connections.
 - Swivel snow blade – supply = **Fig. 203-D**
 - Swivel snow blade – return = **Fig. 203-E**
- Dismantling is in the reverse order.

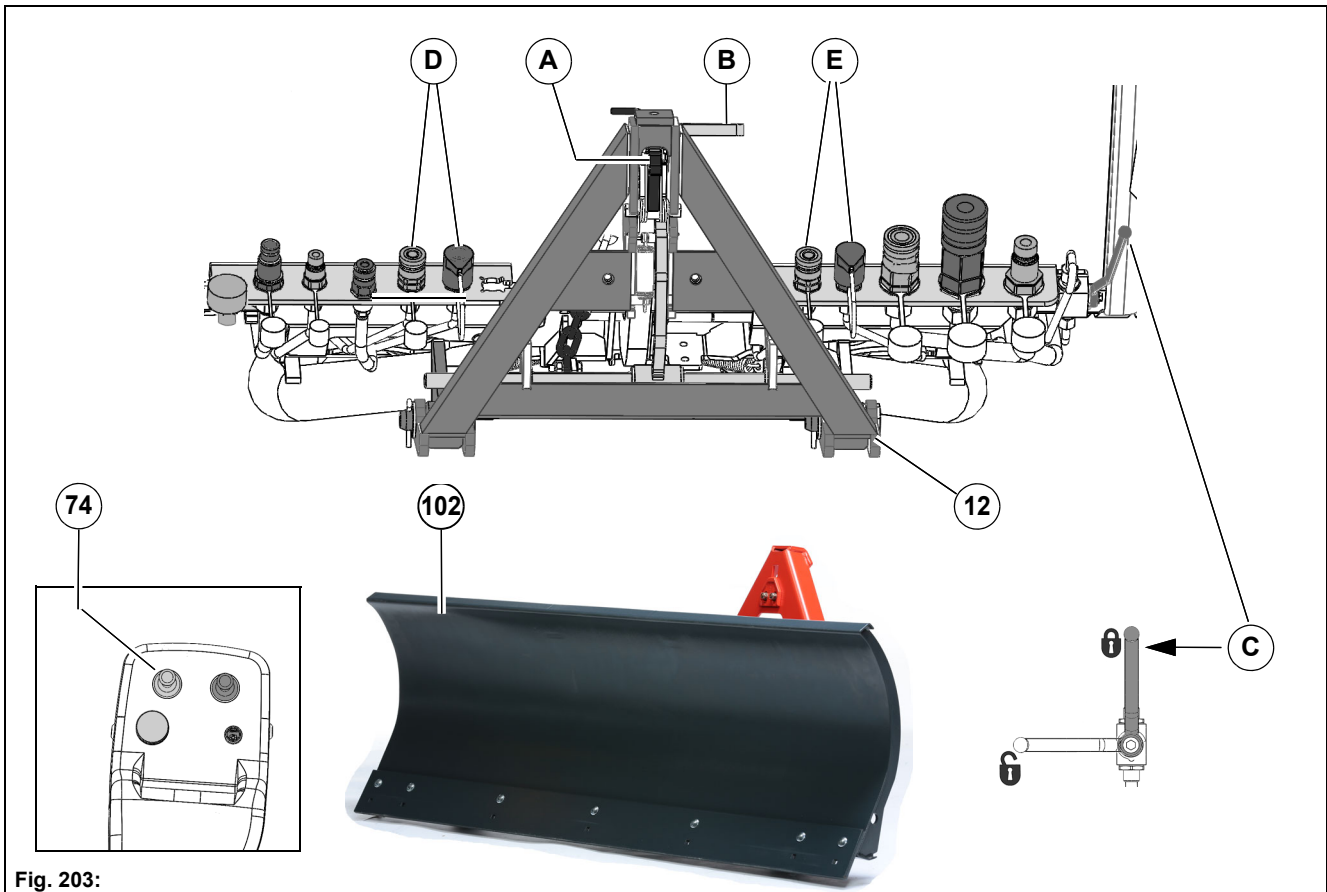


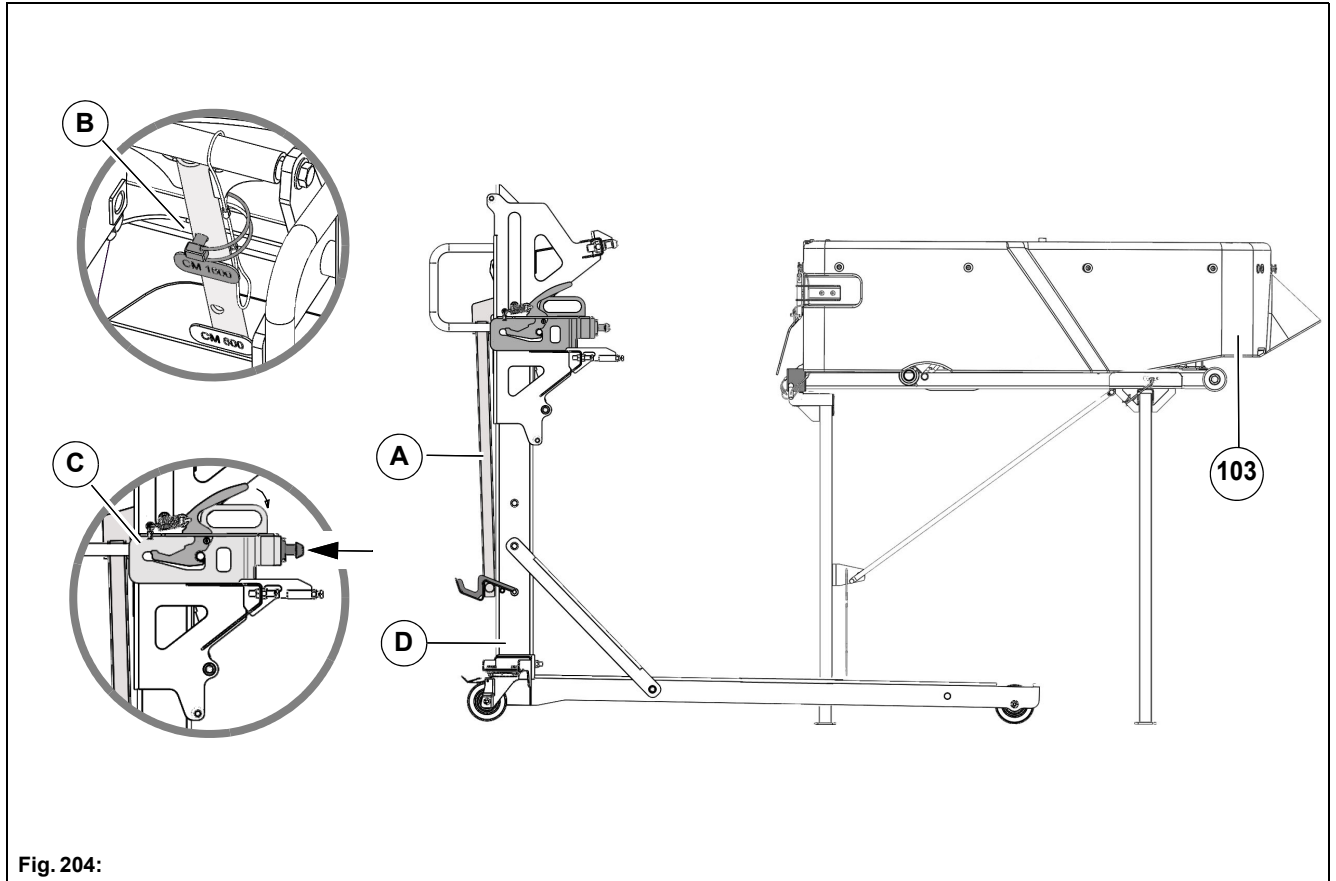
Fig. 203:

Mounting the loading platform

1. Place the vehicle on a level surface and switch off the engine. Engage the parking brake.
2. Unlock the lever **Fig. 204-A** of the trolley **Fig. 204-D** (optional) and swing it into the upper position.
3. Hold the lever **Fig. 204-A** in the upper position with one hand and with the other hand fit the mounting bolt **Fig. 204-B** on the Citymaster 1650.

	<p>Danger Risk of injury! The lever Fig. 204-A can swing over.</p>
---	--

4. Unlock the sledge **Fig. 204-C** with the lever and push it into the rear position.



Continued – Mounting the loading platform



Danger

Risk of injury due to tilting over! Make sure that the cross strut **Fig. 205-B** has been inserted when transporting the loading platform on the supports **Fig. 205-K**. Secure the supports with bolts and splints.

5. Push the trolley **Fig. 205-J** (optional) with the lower positioning aid **Fig. 205-E** into the spars **Fig. 205-G** and against the fixed bearings **Fig. 205-H** of the loading platform **Fig. 205-103**. The screw **Fig. 205-F** must be adjusted to 38.5 mm!
6. Carefully lower the lever **Fig. 205-A** of the trolley and make sure that the locking pins **Fig. 205-I** sit in the holders of the loading platform. Lock the lever.
7. Remove the supports **Fig. 205-K** (optional). To do this, pull out the split pins and the bolts.

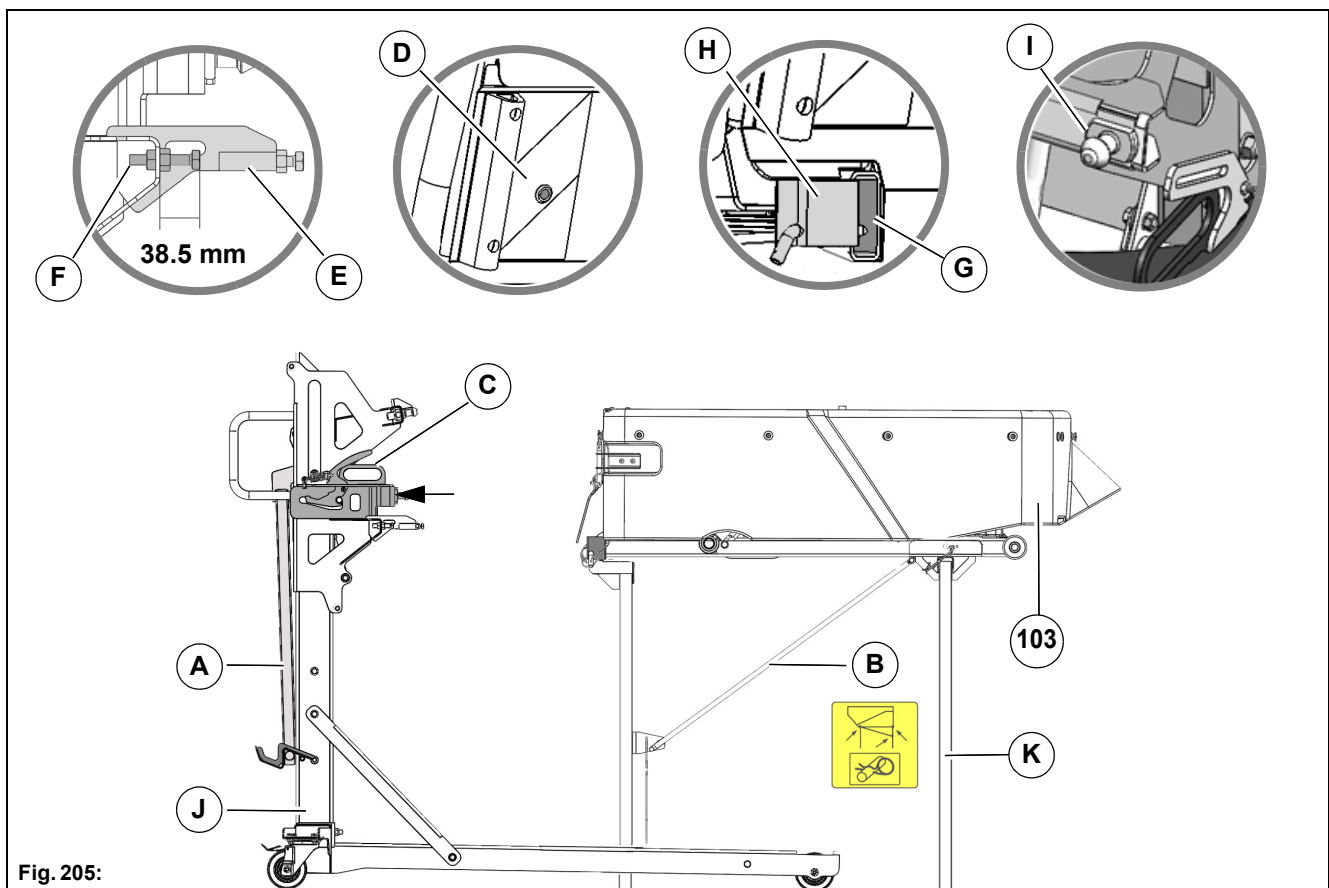


Fig. 205:

Continued – Mounting the loading platform

8. Align the loading platform to the rear wagon:

Procedure:

- Position the loading platform over the rear wagon and check the gap size **Fig. 127-X** with 5-10 mm. If necessary, correct with the adjusting screw **Fig. 127-A**.
- Push the rollers of the loading platform up into the pockets **Fig. 127-B** of the rear wagon.
- The fixed bearings **Fig. 127-C** of the loading platform and the holders **Fig. 127-D** of the rear wagon must be in alignment.

9. Unlock the lever **Fig. 127-E** of the trolley and swing it into the upper position. Let the loading platform down slowly! Withdraw the trolley.

10. Secure the loading platform with bolts and splints.

11. Make the connections.

- Loading platform raising/lowering – Supply/return = **Fig. 206-F**

Dismantling is in the reverse order.

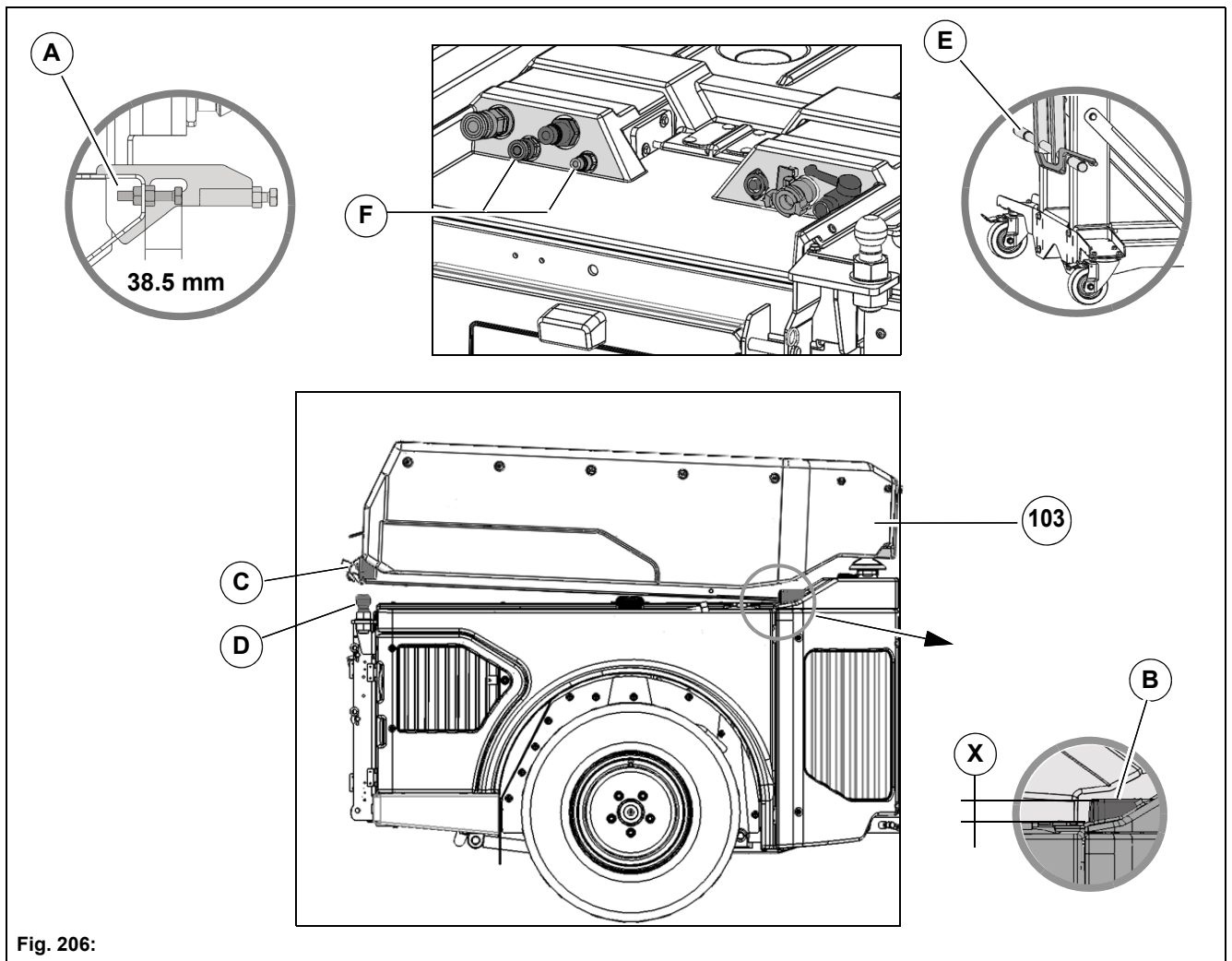
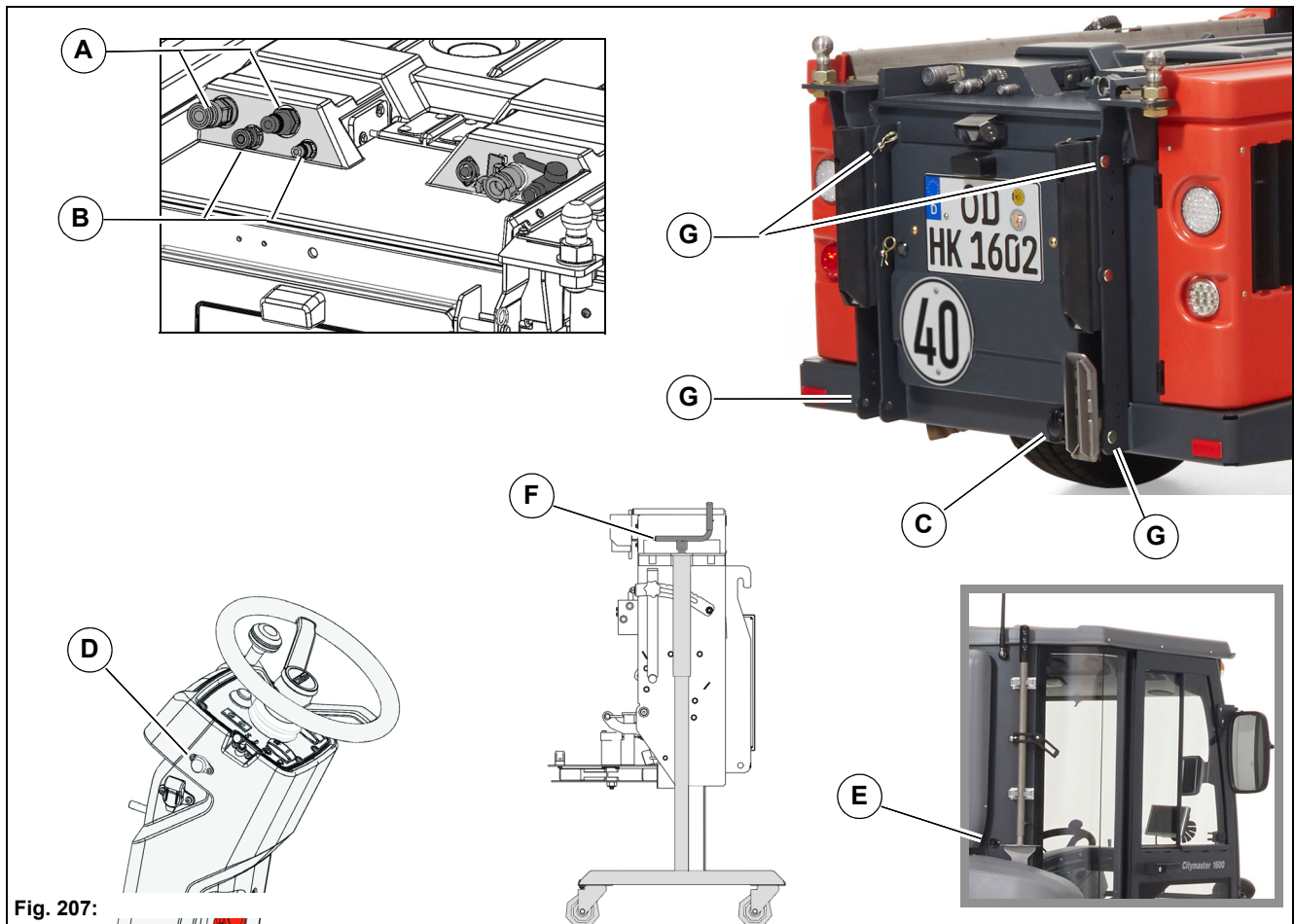


Fig. 206:

Mounting the spreader

1. Place the vehicle on a level surface and hold it with the parking brake. Switch the engine off and pull out the ignition key.
 2. Move the spreader with mounting wagon carefully to the tail of the vehicle and align it.
 3. Make the connections.
 - Spreader roller hydraulic motor – Supply/return **Fig. 207-A**
 - Spreader plate hydraulic motor – Supply/return **Fig. 207-A**
 - X65 – 7-pin socket for lighting **Fig. 207-C**
 - X67 – 7-pin socket for spreader **Fig. 207-D**
 - X68 – 7-pin socket for spreader **Fig. 207-E**
 4. With both cranks **Fig. 207-F** of the trolley lower the spreader evenly onto the holding points **Fig. 207-G** of the vehicle tail end and secure with bolts.
 5. Remove the trolley.
- Dismantling is in the reverse order.
An optional control cable is required for the socket X68.




6.4.4 Operation

Checklist – Before start-up of the snow clearing system

No.	Description	Reference
1	Switching winter operation on	Page 197
2	Adjusting the attack angle	Page 197
3	Loading the loading platform and spreader	Page 197
4	Adjusting the spreading volume	Page 197
5	Adjusting the spreading width	Page 197

Switching winter operation on

Select the configuration menu in the multifunctional display with the turn-push knob **Fig. 208-73** and activate winter operation. The Winter service information symbol **Fig. 208-A** appears in the multifunctional display.

	<p>Warning</p> <p>Activate winter operation in the configuration menu only in connection with an uncoded snow blade. In winter operation the front lift system is not limited downwards. There is a risk of an accident on unintended lowering of the attachment.</p>
---	--

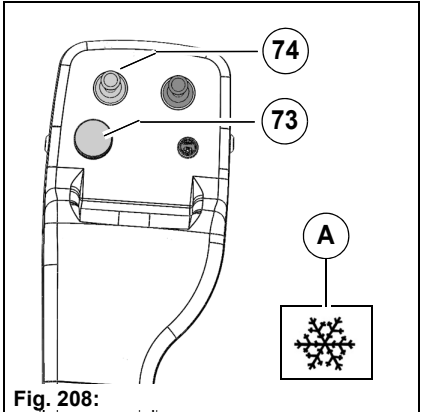


Fig. 208:

Adjusting the attack angle

Adjust the attack angle with the joystick **Fig. 208-74**.

- Joystick to the left: the front attachment swivels to the left
- Joystick to the right: the front attachment swivels to the right

Loading the loading platform

Observe the maximum permissible load of 500 kg when loading the loading platform.

Filling height of the loading platform, see mark **Fig. 209-A**. Load capacity of the tie-down eyes **Fig. 209-B**: maximum 250 daN. You can use the separating board **Fig. 209-C** for different materials.

Loading the spreader

Different specific weights arise according to the condition of the spread material (wet or dry). Check the specific weight of the spread material before filling.

Payload of the spreader, see operating manual of the spreader.

Adjusting the spread volume

Adjusting the spread volume, see operating manual of the spreader.

Adjusting the spreading width

The spreading width depends on the condition of the spread material and the speed of the spreading disk. The more coarse grained the spread material is, the larger is the possible spreading width.

Adjusting the spreading width, see operating manual of the spreader.

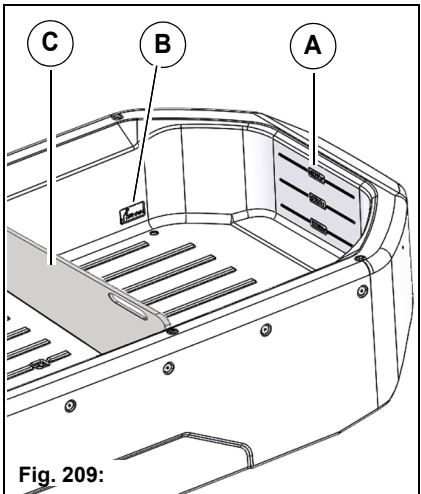


Fig. 209:

Checklist – Snow clearing

No.	Description	Reference
1	Driving to the work site	Page 198
2	Switching snow clearing on	Page 198
3	Setting the fixed engine speed	Page 199
4	Starting snow clearing	Page 199

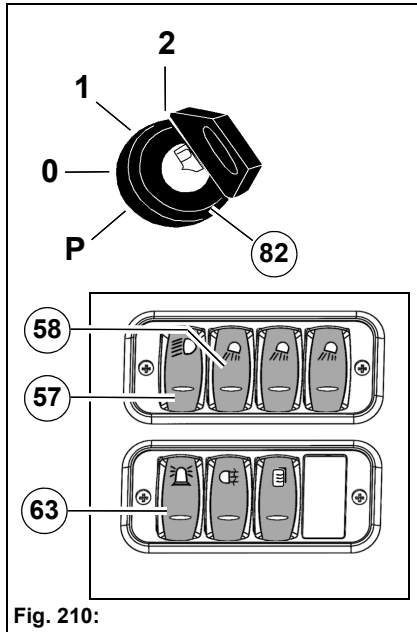


Fig. 210:

Driving to the work site

1. Bring the snow blade into the transport position, see page 173.
2. Start the vehicle with the ignition switch **Fig. 210-82**.
3. As required, switch on the dipped headlight **Fig. 210-57**, working light **Fig. 210-58** and rotating beacon **Fig. 210-63**.
4. Drive to the work site in the transport mode. The front attachment must be in the upper end position for the transport mode. Push the joystick **Fig. 211-74** back for this purpose.

Switching snow clearing on

1. With the joystick **Fig. 211-74** lower the snow blade into the floating position.
2. Start snow clearing in the transport mode.



Note

For snow clearing with the front sweeping machine, the procedure is similar to that described on page 181.

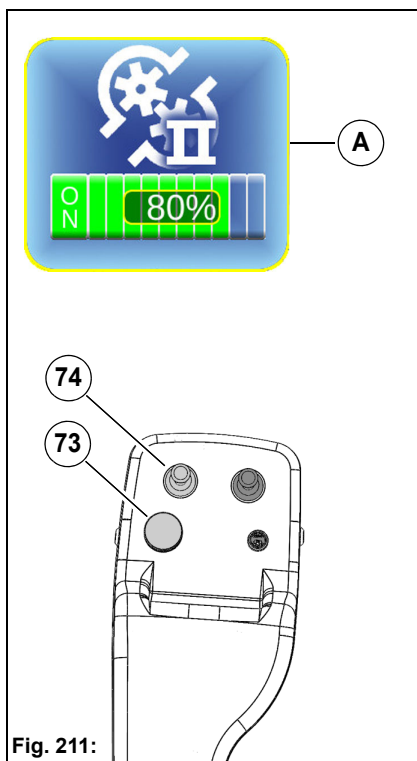


Fig. 211:

Switching spreading on

1. Use the turn-push knob **Fig. 211-73** in the working menu to switch on the hydraulic circuit II for rear attachments **Fig. 211-A** and to set the desired speed.
2. Start spreading in the transport mode.



Note

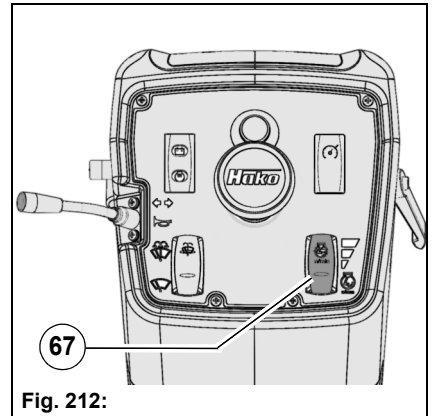
The following functions can also be set in the configuration menu:

- Spreader run-on: ON/OFF
- Spreader fast emptying: 0 to 4 seconds
- Spreader depending on the pedal setting: ON/OFF

Setting the fixed engine speed

The fixed engine speed is set with the tip switch **Fig. 212-67**. Set the speed according to the requirements.

Stage	rpm	Use
1 - ECO	1600	At low load
2 - Standard	2000	For medium load
3 - Maximum	2400	For high load



Starting snow clearing

The accelerator pedal **Fig. 213-38** is used for continuously changing the speed for driving forwards.

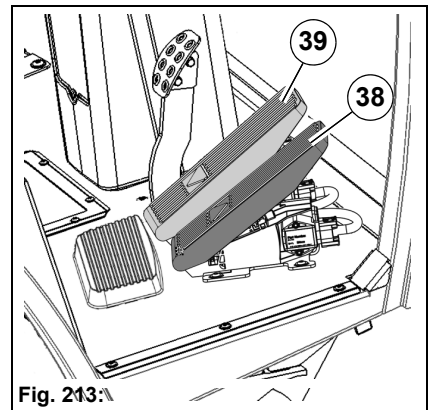
The accelerator pedal **Fig. 213-39** is used for continuously changing the speed for reversing.

Push the accelerator pedal down slowly until the vehicle starts, the speed is increased further by pressing on the pedal.

Slowing down or braking the vehicle: slowly reduce the pressure on the accelerator pedal, the vehicle slows down or stops.

The vehicle speed in the:

- transport mode is 0 to 40 km/h,
- work mode 16/20/27km/h according to selected engine speed.



	<p>Attention Before you leave the vehicle, the attachment must be lowered to the ground!</p>
--	---

6.4.5 Technical data

Snow blade	Unit	
Working width	mm	1400
Share height	mm	500

Loading platform	Unit	
Load on the loading platform	kg	max. 500

You will find information on technical data in the operating manual of the spreader.

6.4.6 Maintenance

You will find information about the maintenance plan and maintenance work in the operating manual of the snow blade.

6.4.7 Accessories

Your authorised Hako dealer is available to you at any time to answer questions on accessories for the snow clearing system.

6.5 Transport system




Fig. 214:

Item	Designation
105	Trailer (optional)
106	Trailer hitch plate (optional)

6.5.1 Labels on the unit

Labels on the unit, see operating manual of the trailer.

6.5.2 Safety instructions

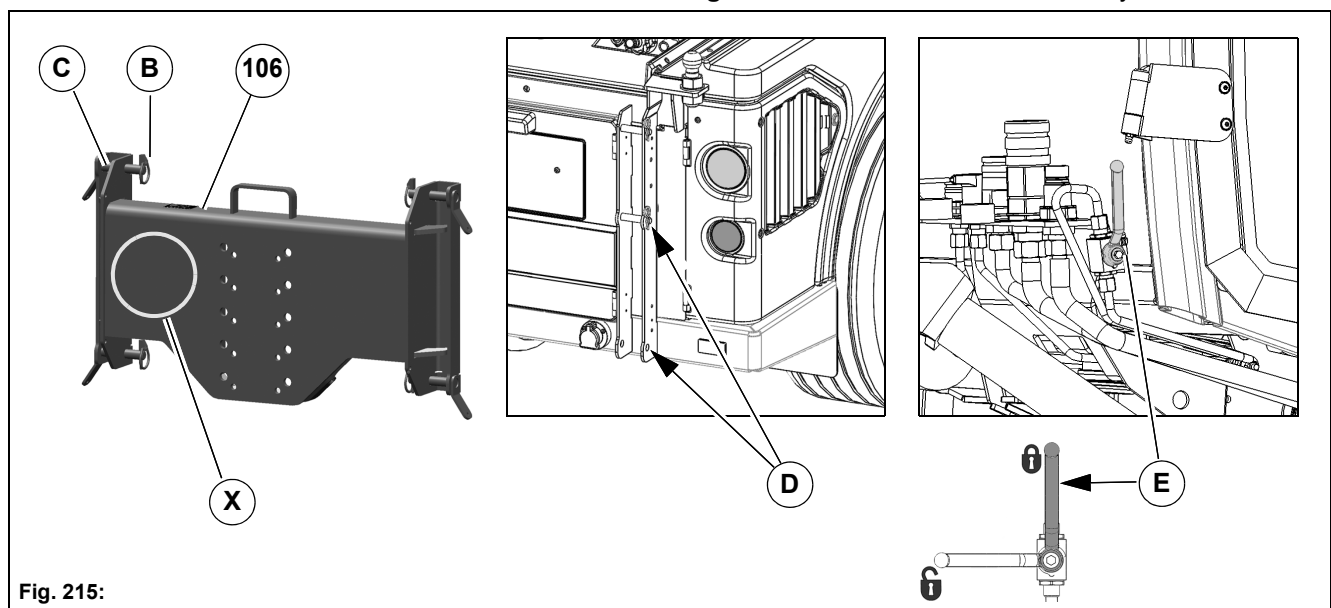
	<p>Danger</p> <ul style="list-style-type: none"> • Danger to life in the danger area of the vehicle! Special caution is required in the vicinity of the articulated steering, beneath the raised tipper and in the area between the vehicle and the trailer. • Danger to life due to inadequately secured load! The load must be correctly distributed and fastened on the loading surface. • Risk of injury! Modifying the safety equipment is not permitted! • Risk of accident! Adopt measures against erroneous starting and unwanted movement. Switch the engine off and pull out the ignition key. • Risk of accident! You must consult Hako before attaching other attachments not approved by Hako! <p>Warning</p> <ul style="list-style-type: none"> • The transport system may be operated only in connection with the Citymaster 1650. The safety regulations for the Citymaster 1650 must be complied with absolutely. <p>Caution</p> <ul style="list-style-type: none"> • The labels attached to the vehicle provide important information for safe operation. Renew labels that are no longer legible or present. • Spare parts must be original spare parts to guarantee safety.
---	--

6.5.3 Mounting


Mounting the trailer hitch plate (optional)

The trailer hitch plate **Fig. 215-106** is mounted without tools to the tail of the vehicle.

1. Remove the locking pins **Fig. 215-B** of the four bolts **Fig. 215-C** of the trailer hitch plate and withdraw the bolts.
2. Position the trailer hitch plate on the vehicle.
3. Secure the trailer hitch plate with bolts and locking pins to the holding points **Fig. 215-D** of the vehicle tail.
4. If necessary, remove the footrest (optional) and collision protection (optional).
5. Affix the Speed label at position **Fig. 215-X**.
6. Close the valve **Fig. 215-E** for the suction mouth lift system!



Mounting the jaw coupling (optional)

	<p>Note The trailer hitch plate option is required for mounting the jaw coupling.</p>
---	--

Mount the jaw coupling **Fig. 216-A** with the bolts, washers and nuts to the optional trailer hitch plate in the wanted height.
Four setting heights are available.

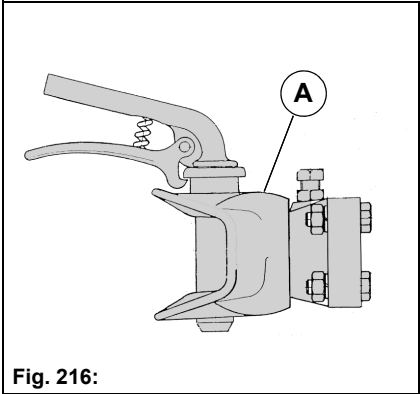



Fig. 216:

Mounting the ball head coupling (optional)

	<p>Note The trailer hitch plate option is required for mounting the ball head coupling.</p>
---	--

Mount the ball head coupling with the bolts, washers and nuts to the optional trailer hitch in the wanted height.
Four setting heights are available.

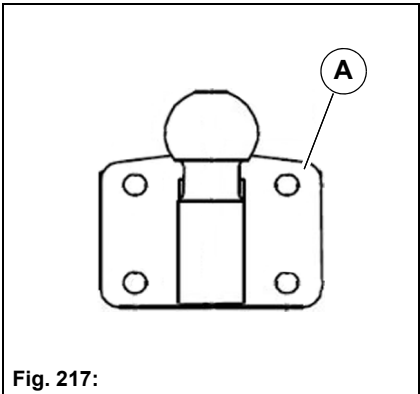

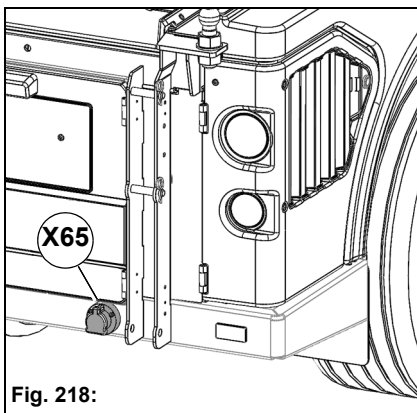


Fig. 217:

6.5.4 Operation

	<p>Warning</p> <ul style="list-style-type: none"> • Only put the attachment into service if all instructions stipulated in the operating manual of the attachment manufacturer have been observed. • There is a risk of being crushed at the drawbar. Make sure your hands do not reach into the crushing zone. • Before driving with the vehicle, fully raise and secure the support wheel. The support wheel may be torn off and fly off when driving! • Drive with extreme caution when towing a trailer, since the braking distance is longer than usual! <p>Caution</p> <ul style="list-style-type: none"> • Pay attention to the maximum support load of the trailer coupling. • Also secure trailer with wheel chocks when parking the vehicle on a slope! • Also load the loading surface of the towing vehicle in order to increase traction, reduce the slip between the tyres and the road surface and also reduce tyre wear, and increase general driving safety.
---	--

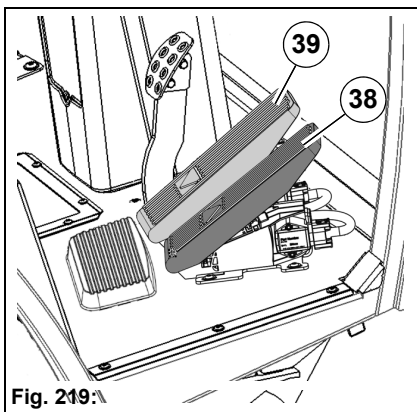


Coupling the trailer

1. Apply the parking brake of the trailer.
2. Set the trailer drawbar to the height of the coupling on the towing vehicle.
3. Attach the trailer to the jaw coupling or the ball head coupling.
4. Check the locking of the coupling.
5. Release the height setting of the drawbar or remove the support.
6. Hitch the arrester cable on trailers with overrun brakes.
7. Establish connections and check functioning.
8. Remove the wheel chocks and release the parking brake of the trailer.
9. Check the brakes after moving the vehicle.

Uncoupling the trailer

1. Stop the vehicle and apply the parking brake of the towing vehicle.
2. Apply the parking brake of the trailer.
3. Undo connections.
4. Secure towing drawbar to prevent it from falling down.
5. Open coupling and slowly drive towing vehicle away.



Starting transport

The accelerator pedal **Fig. 219-38** is used for continuously changing the speed for driving forwards.

The accelerator pedal **Fig. 219-39** is used for continuously changing the speed for reversing.

Push the accelerator pedal down slowly until the vehicle starts, the speed is increased further by pressing on the pedal.

Slowing down or braking the vehicle: slowly reduce the pressure on the accelerator pedal, the vehicle slows down or stops.

The vehicle speed in the:

- transport mode is 0 to 40 km/h,
- work mode 16/20/27 km/h according to selected engine speed.

6.5.5 Technical data

Single-axle trailer	Unit	
Length	mm	2200
Width	mm	1300
Height	mm	300
Payload	kg	1450
Gradability in trailer operation at total combination load	%	20
Trailer hitch plate	Unit	
Trailer load braked	kg	2000
Trailer load unbraked	kg	750
Support load	kg	max. 150

6.5.6 Maintenance

You will find information about the maintenance plan and maintenance work in the operating manual of the trailer.

6.5.7 Accessories

Your authorised Hako dealer is available to you at any time to answer questions on accessories for the transport system.

6.6 Wet cleaning system



Fig. 220:

Item	Designation
107	Scrubbing deck of the CityCleaner
108	Squeegee of the CityCleaner
109	Trolley (optional)
110	Chemical dosing system (optional)
111	Detergent (optional) CityClean-O and CityClean-S
112	Water supply (optional)
113	Brush pressure (optional)

6.6.1 Labels on the unit

Type plate

The type plate **Fig. 220-A** is located at the front of the CityCleaner.

Hako name plates

The Hako name plates **Fig. 220-B** are located at the front left and right of the CityCleaner.


6.6.2 Mounting


Mounting sequence

1. Remove the squeegee from the trolley and mount it on the vehicle.
2. Remove the scrubbing deck from the trolley and mount it on the vehicle.
3. Mounting the dirt hopper.

Disassembly sequence

1. Disassemble the dirt hopper.
2. Disassemble the scrubbing deck from the vehicle and place it onto the trolley.
3. Disassemble the squeegee from the vehicle and place it onto the trolley.

	<p>Note Mounting of the dirt hopper is described in the Vacuum sweeping system section.</p>
---	--

	<p>Danger</p> <ul style="list-style-type: none"> • Danger to life in the danger area of the vehicle! Special caution is required in the vicinity of the articulated steering and beneath the raised tipper. • Risk of injury! Modifying the safety equipment is not permitted! • Risk of accident! Adopt measures against erroneous starting and unwanted movement. Switch the engine off and pull out the ignition key. • Risk of accident! You must consult Hako before attaching other attachments not approved by Hako! <p>Warning</p> <ul style="list-style-type: none"> • Risk of crushing! The squeegee of the CityCleaner weighs more than 25 kg. Body parts may be crushed if the squeegee falls down or falls over. Always use suitable load-carrying equipment. • Risk of injury! Wear suitable protective clothing (protective gloves and safety goggles) when using detergents. • Risk of injury! There is a risk of tilting over if the squeegee is located on the trolley without the scrubbing deck. Observe the correct assembly and disassembly sequence. • Risk of injury! Always wear protective gloves when working on the lateral deflectors and brushes. <p>Caution</p> <ul style="list-style-type: none"> • The labels attached to the vehicle provide important information for safe operation. Renew labels that are no longer legible or present. • Spare parts must be original spare parts to guarantee safety. • Limited ground clearance! When driving on the kerb, a max. threshold of 120 mm can be driven on with a mounted squeegee. • After disassembling the CityCleaner, secure the trolley against rolling away.
---	--

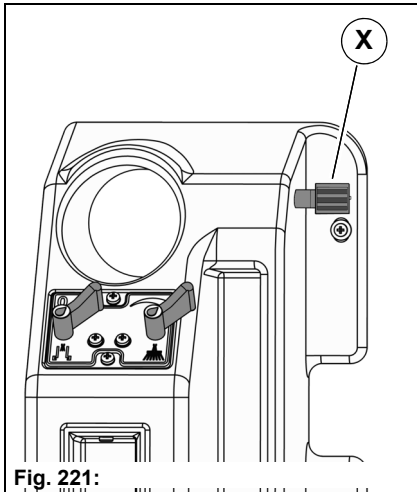


Fig. 221:

Mounting the squeegee



Note

If there is circulating water in the dirt hopper, the ball cock **Fig. 222-10** of the circulating water stop valve (right side of articulation area) must be shut off!

1. Place the vehicle on a level surface and hold it with the parking brake.
2. Raise the front tool carrier and fix it in the upper position with the lowering valve **Fig. 221-X**.
3. Remove the squeegee **Fig. 222-108** from the trolley and position it by hand centrally under the holding plate **Fig. 222-A**.
4. Open the ball cock **Fig. 222-G**. Push the joystick **Fig. 222-74** forwards. When the ball cock is open, the holding plate is lowered onto the squeegee.
5. Shift the squeegee centrally under the holding plate until the stops **Fig. 222-B** come up to the points **Fig. 222-C**.
6. With the lever **Fig. 222-D** lock and secure the squeegee on the counter bearing **Fig. 222-E** of the holding plate, see sketch **Fig. 222-F**.
7. Open the lowering valve **Fig. 221-X** again.

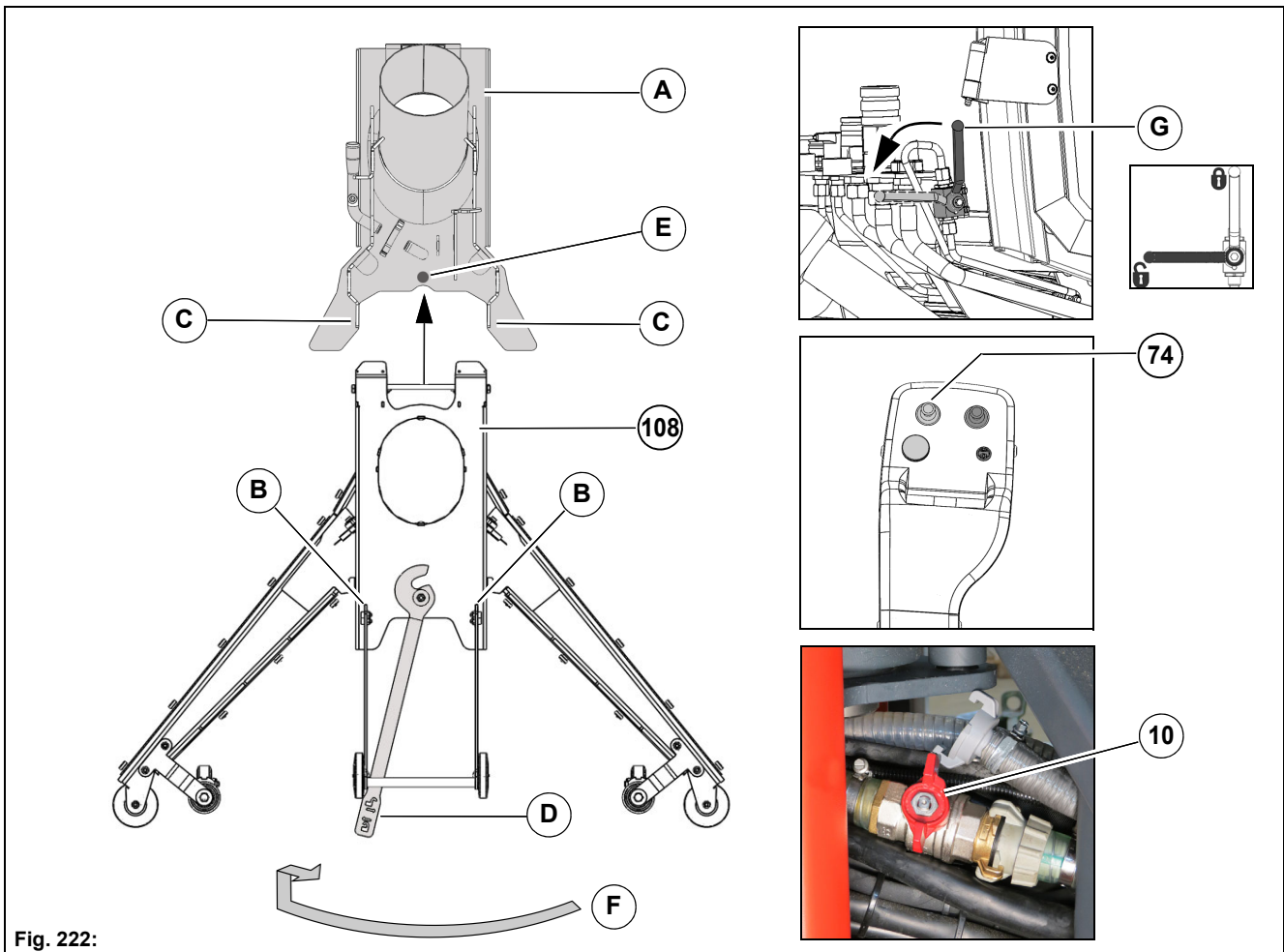


Fig. 222:

Mounting the scrubbing deck

1. Unlock the locking hook **Fig. 223-E** and the locking rod **Fig. 223-F** on the front tool carrier **Fig. 223-12**. Position the front tool carrier to the holder of the scrubbing deck with the joystick **Fig. 223-74**.
2. Bring the locking bow **Fig. 223-D** into the working position.
 - Working position = **Fig. 223-A** (brush symbol)
 - Maintenance position = **Fig. 223-B** (wrench symbol)
 - Transport position = **Fig. 223-C** (vehicle symbol)
3. Use the trolley **Fig. 223-109** (optional) to align the scrubbing deck **Fig. 223-107** centrally and in alignment with the front tool carrier.
4. Raise the front tool carrier **Fig. 223-12** with the joystick **Fig. 223-74** and attach the scrubbing deck.
5. Lock the scrubbing deck with the locking hook and the locking rod.

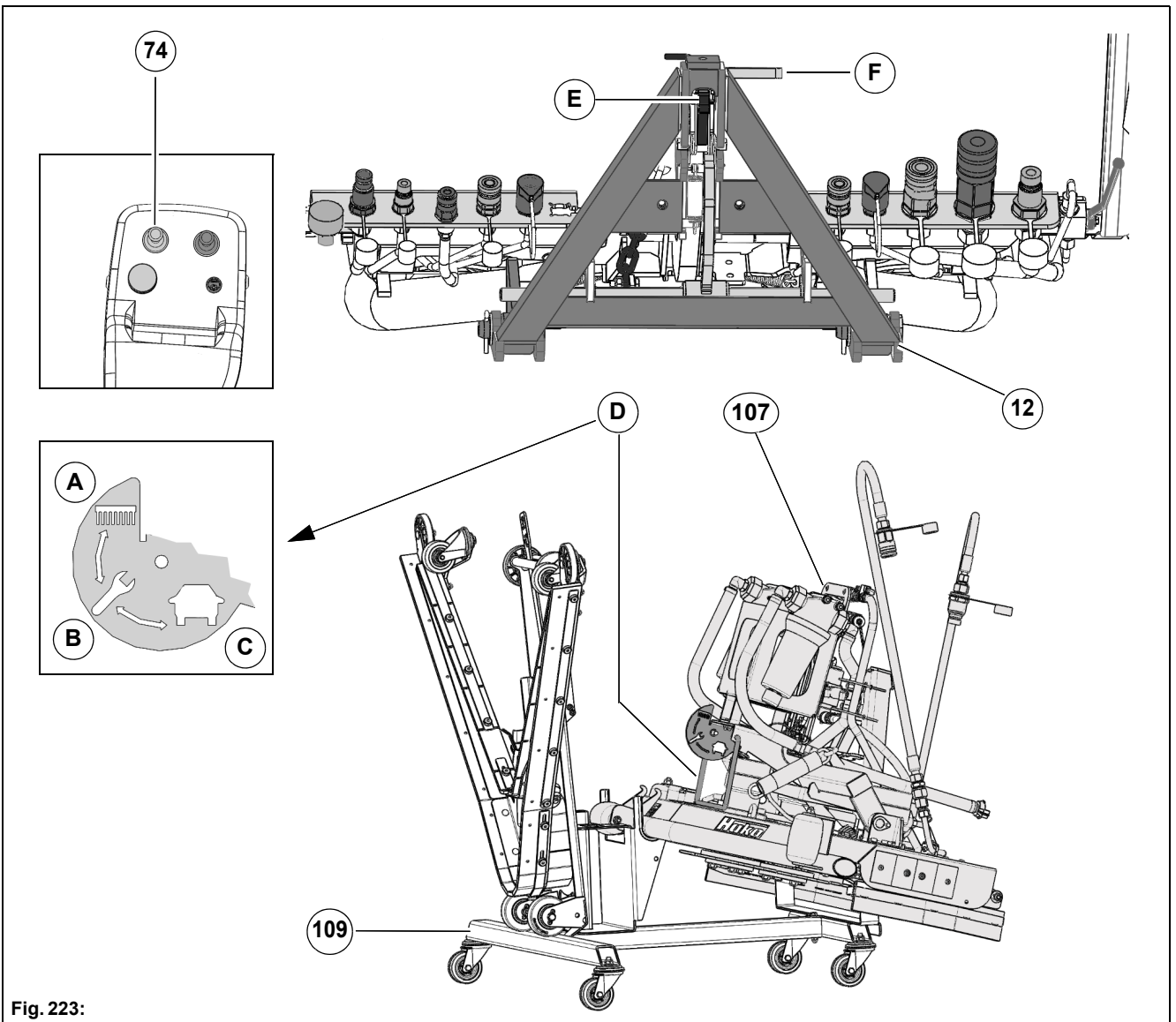


Fig. 223:

Continued – Mounting the scrubbing deck

6. Withdraw the trolley.
 7. Remove the circulating water hose **Fig. 224-A** of the vacuum sweeping system at the ball cock.
 8. Mount the yellow marked circulating water hose **Fig. 224-B** of the scrubbing deck (rotating coupler).
 9. Establish the connections at the scrubbing deck:
 - Scrubbing deck hydraulic motors – Supply/return = **Fig. 224-C**
 - 19-pin coding plug = **Fig. 224-D**
 - Fresh water coupling (quick coupler) = **Fig. 224-E**
 - Circulating water coupling (rotating coupler) = **Fig. 224-F**
 10. Hook the chain **Fig. 224-G** onto the hook **Fig. 224-H**.
 11. Open the ball cock **Fig. 224-10** of the circulating water stop valve (right side of articulation area) again.
- Dismantling is in the reverse order.

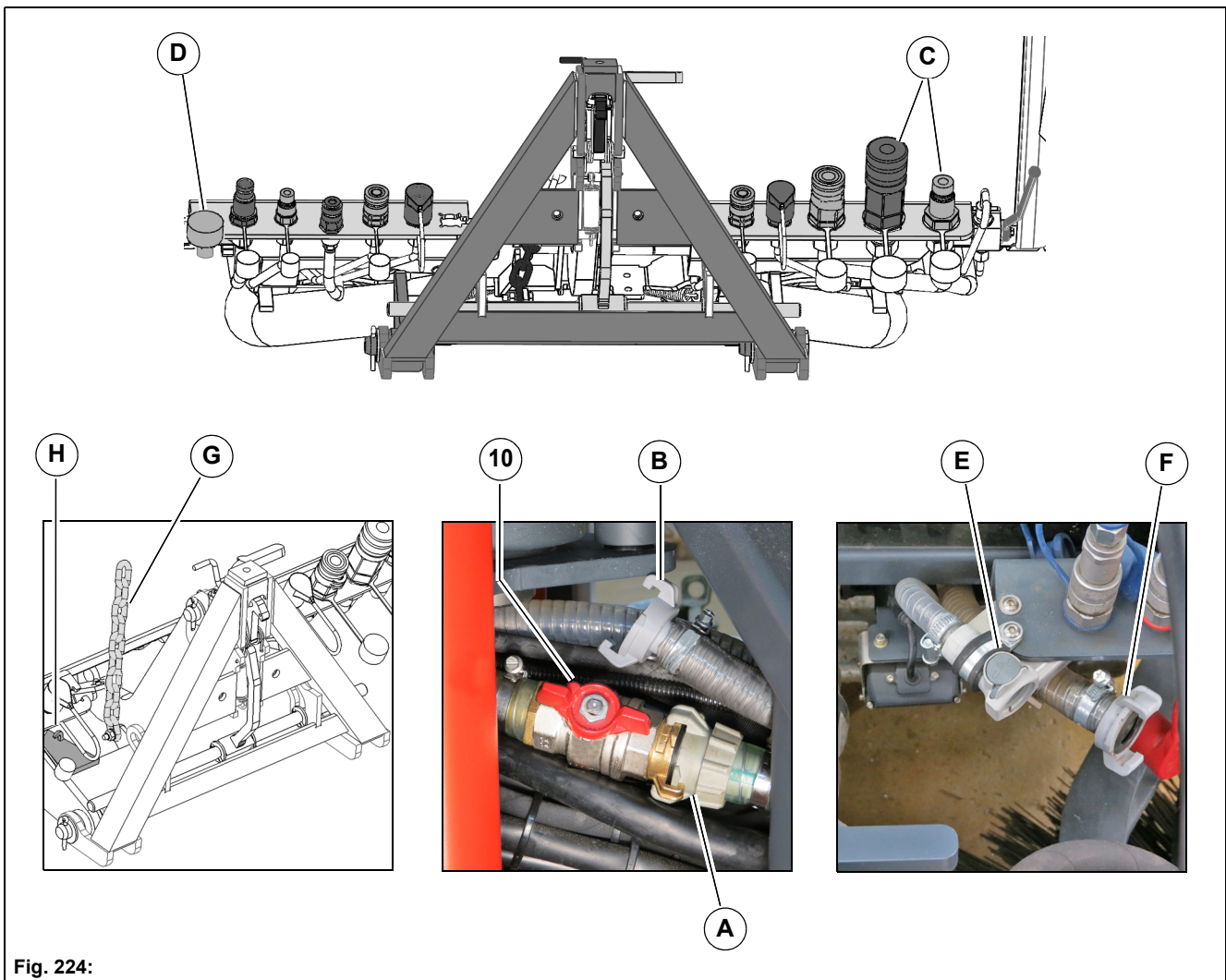
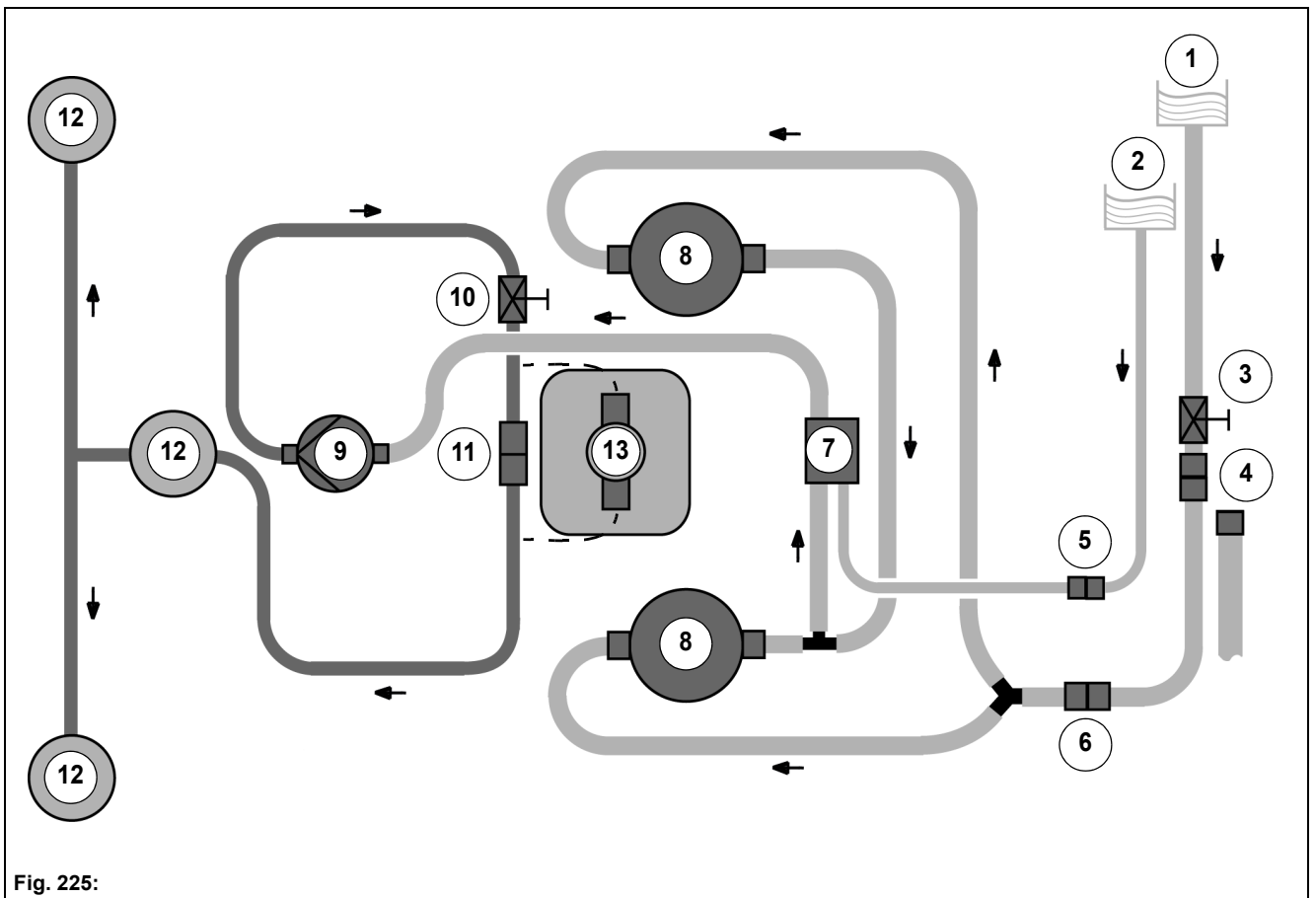


Fig. 224:

Water diagram

- 1 Dirt hopper
- 2 Fresh water tank
- 3 Ball cock circulating water in the articulation area
- 4 Circulating water rotating coupler in the articulation area
 - Wet cleaning system = small hose (yellow mark)
 - Vacuum sweeping system = large hose
- 5 Fresh water quick coupler (at the front tool carrier)
- 6 Circulating water rotating coupler (at the front tool carrier)
- 7 Solenoid valve (at the scrubbing deck)
- 8 Circulating water filter (at the scrubbing deck)
- 9 Water pump (at the scrubbing deck)
- 10 Shut-off valve (at the scrubbing deck)
- 11 Quick coupler (at the scrubbing deck)
- 12 Brushes (at the scrubbing deck)
- 13 Chemical dosing system (at the scrubbing deck)



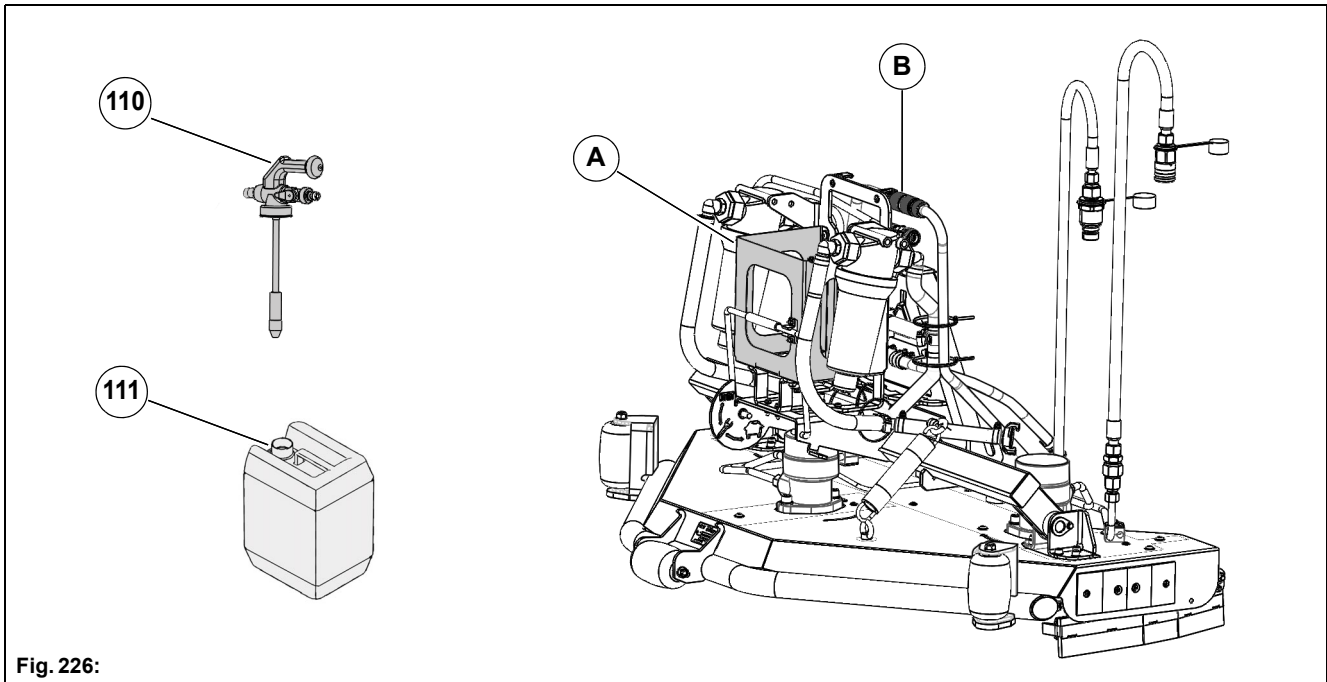
Mounting the chemical dosing system (optional)



Warning

Risk of injury! Wear suitable protective clothing (protective gloves and safety goggles) when using detergents.

Insert the chemical hopper **Fig. 226-111** into the holding box **Fig. 226-A**. Remove the lid of the chemical hopper and insert the chemical dosing system **Fig. 226-110** and screw it to the chemical hopper. Open the quick coupler **Fig. 226-B** and connect it to the chemical dosing system.



6.6.3 Operation

Checklist – Before start-up of the wet cleaning system


No.	Description	Reference
1	All items from the checklist – Check before starting the vehicle	Page 83
2	Filling fresh water	Page 138
3	Filling circulating water	Page 213
4	Checking the ball cock circulating water	Page 139
5	Checking the chemical dosing system (optional)	Page 214
6	Checking the squeegee sealing strips, turn or replace them if necessary	Page 223
7	Checking the lateral deflectors, turn or replace them if necessary	Page 224
8	Checking the brushes, replace them if necessary	Page 225

Filling fresh water

Open the cap **Fig. 128-A** and fill the fresh water tank **Fig. 128-8** until the level indicator in the multifunctional display reaches the maximum level or it looks full.

Hydrant kit (optional)

Filling the fresh water tank from the public water mains with the D hose connection is possible with the hydrant kit (optional). The hydrant kit is mounted above the filling cap and contains a C hose connection, a D hose connection, an installation key and a free-fall section.

	<p>Note Water may be taken from the mains of public water connections only through the "D-hose connection"!</p>
---	--

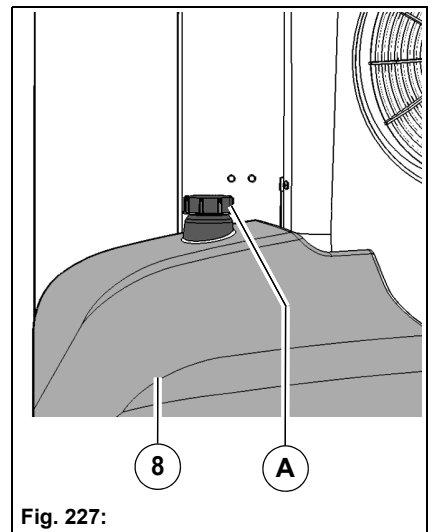



Fig. 227:

Filling circulating water

1. Switch off the suction fan of the dirt hopper!
2. Open the lock **Fig. 129-A** of the dirt hopper.
3. Adjust the rear flap with the lever **Fig. 129-B**.
4. Fill the dirt hopper using a water hose. Use the side C hose connection as an alternative.
5. Fill the dirt hopper up to the upper mark of the hinge pivotal point **Fig. 129-C**. Filling volume for circulating water approx. 390 litres.

	<p>Note Fill less circulating water into the dirt hopper when it is raining or wet.</p>
---	--

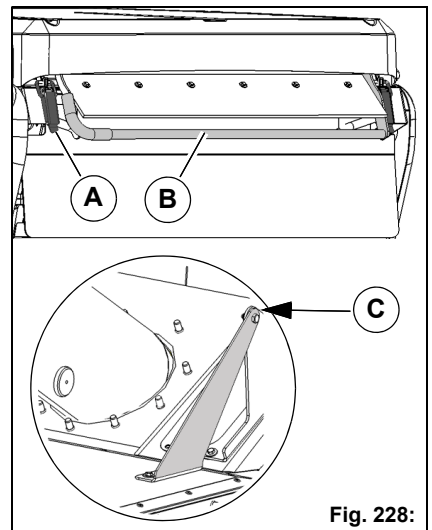
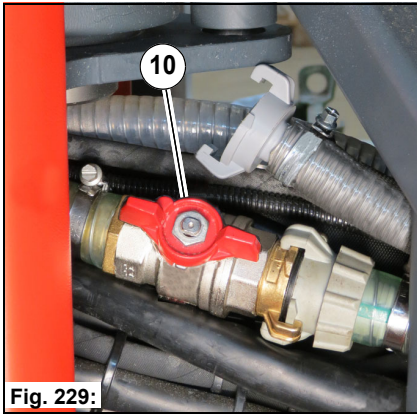


Fig. 228:



Checking the ball cock circulating water

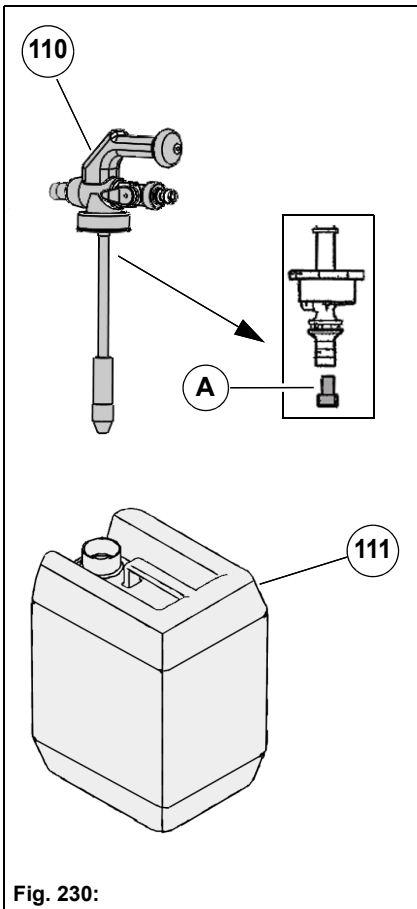
The circulating water is closed off only with the ball cock for maintenance purposes. In normal operation the ball cock **Fig. 229-10** must be opened!

- Circulating water supply opened: butterfly handle in flow direction
- Circulating water supply closed: butterfly handle at right angles to the flow direction



Note

Close off the circulating water supply only if there is circulating water in the dirt hopper and the squeegee should be mounted or dismantled.



Checking the chemical dosing system (optional)

Remove the quick coupler at the chemical dosing system. Loosen the screw connection and remove the chemical dosing system **Fig. 230-110** from the chemical hopper **Fig. 230-111**. Check the level of the detergent. If required, insert a new chemical hopper.

Select detergent/set mixing ratio:

- CityCleaner-S (7386)
 - Yellow nozzle = 128:1 (0.77%) for normal soiling
- CityCleaner-O (7385) for removing oil leaks
 - Yellow nozzle = 128:1 (0.77%) for light oil contamination
 - Brown nozzle = 96:1 (1.03%) for heavy oil contamination



Note

The concentration of the detergent increases with every cycle of the circulating water!

Setting the mixing ratio:

The nozzle **Fig. 230-A** is located in the suction hose of the chemical dosing system. The mixing ratio of the detergent is set by selecting the nozzle. The various nozzles are located in the accessories kit of the chemical dosing system.



Note

Please also observe the information of the chemical dosing system and the detergent.

Checklist – Wet cleaning

No.	Description	Reference
1	Driving to the work site	Page 215
2	Switching wet cleaning on	Page 216
3	Setting the fixed engine speed	Page 142
4	Basic and upkeep cleaning	Page 216
5	Cleaning heavily soiled surfaces	Page 217
6	Starting wet cleaning	Page 218

Driving to the work site

1. Start the vehicle with the ignition switch **Fig. 133-82**.
2. As required, switch on the dipped headlight **Fig. 133-57**, working light **Fig. 133-58** and rotating beacon **Fig. 133-63**.
3. Prepare the transport mode:
 - Raise the front tool carrier with the joystick **Fig. 134-74**.
 - Bring the scrubbing deck into the transport position (vehicle symbol) using the locking bow **Fig. 133-A**.
4. Push the accelerator pedal **Fig. 133-38** down slowly until the vehicle starts, the speed is increased further by pressing on the pedal. The transport mode information symbol **Fig. 133-C** appears in the multifunctional display.
5. Slowing down or braking the vehicle: slowly reduce the pressure on the accelerator pedal, the vehicle slows down or stops. The driving speed in the transport mode is 0 to 40 km/h.
6. At the work site, bring the locking bow **Fig. 133-A** into the working position (brush symbol) and clamp it to the holder **Fig. 133-B**.

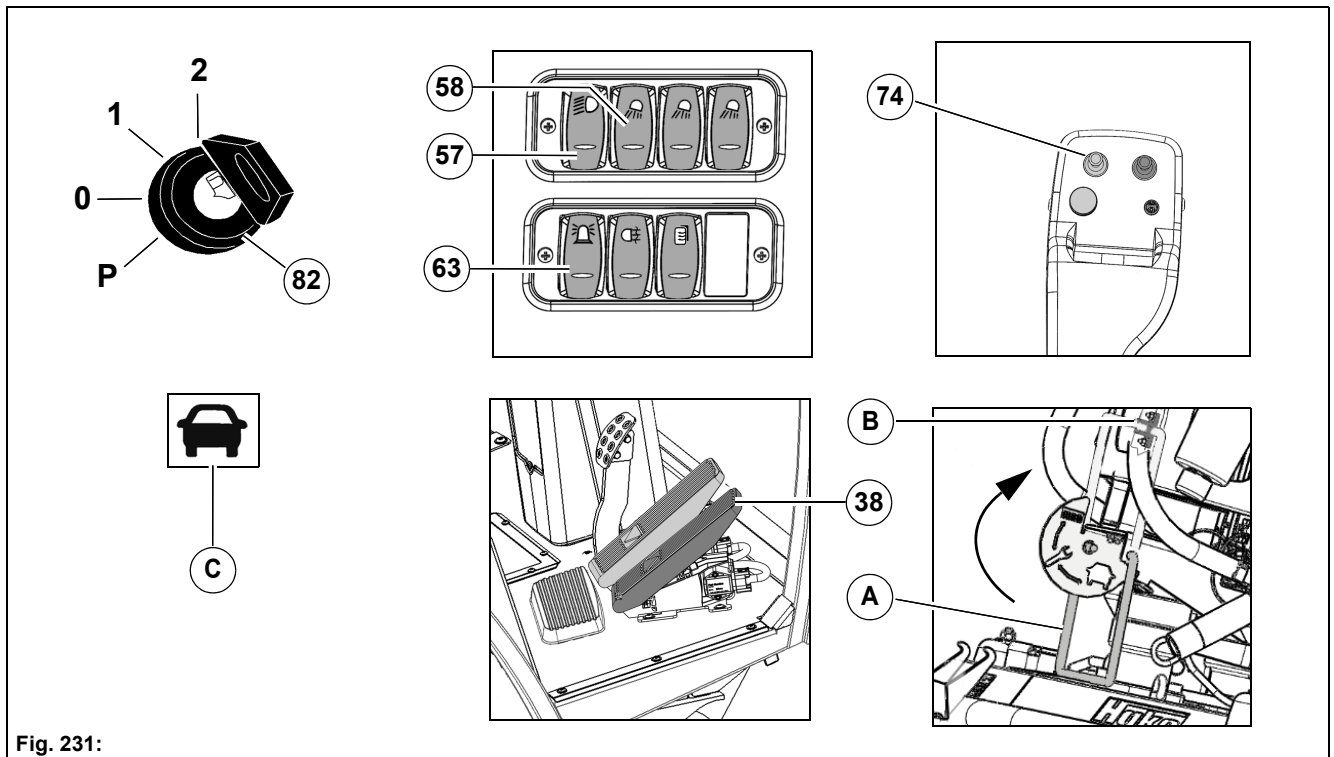


Fig. 231:

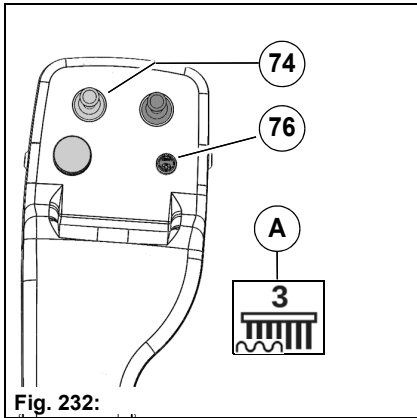


Fig. 232:

Switching wet cleaning on

Switch on the work mode with the Hako button **Fig. 134-76**. The accelerator pedals must be in the neutral position.

The wet cleaning system work mode information symbol appears in the multifunctional display **Fig. 134-A**.

For a coded attachment, the Citymaster 1650 can automatically activate the following functions through the Hako button:

- The scrubbing deck is lowered (floating position)
- The squeegee is lowered
- The suction fan is switched on

The water pump and the brush drives are switched on with the accelerator pedal. The brushes rotate at the set speed.

The settings for wet cleaning can be changed in the multifunctional display, see Checklist – Settings for wet cleaning. The last saved settings are activated automatically when pressing the Hako button **Fig. 134-76**.

If the driver leaves the driver's seat, the water supply is interrupted and the brush drives switched off.

Restarting:

- The driver must be on the driver's seat.
- Move the joystick **Fig. 134-74** forwards.

Basic and upkeep cleaning

- Select the detergent, see Section Maintenance
- Set the mixing ratio, see Section Maintenance
- Select the brushes, see Section Maintenance
- Set the brush speed, suction fan speed and brush pressure in the working menu of the multifunctional display, see Section Checklist – Settings for wet cleaning.

Apply and remove detergent in a single workstep. The squeegee can still move freely. To do this, open the ball cock **Fig. 233-A**. Press the Hako button **Fig. 233-76** and start the workstep.

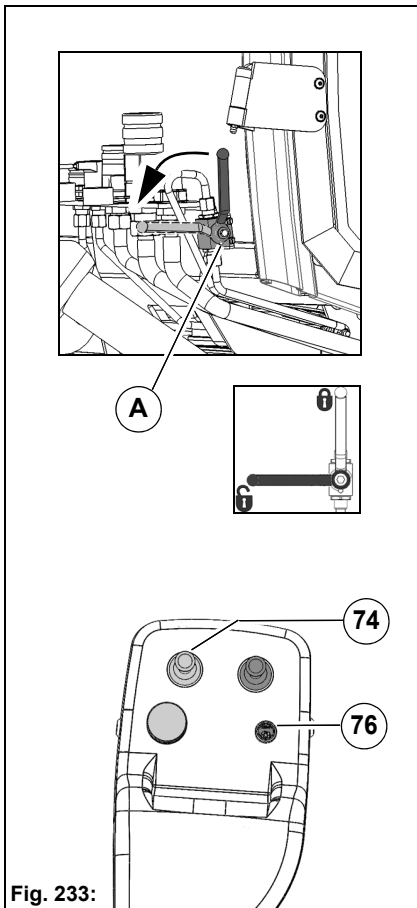


Fig. 233:

Cleaning heavily soiled surfaces

- Select the detergent, see Section Maintenance
- Set the mixing ratio, see Section Maintenance
- Select the brush, see Section Maintenance
- Set the brush speed, suction fan speed and brush pressure in the working menu of the multifunctional display, see Section Checklist – Settings for wet cleaning.

Furthermore, it is possible to enhance the cleaning result by performing the cleaning process in two worksteps.

First workstep (soaking):

Move the CityCleaner into the upper position with the joystick **Fig. 234-74** and fix the squeegee into position by closing the ball cock **Fig. 234-A**.

Press the Hako button **Fig. 234-76** and start the first workstep. During this workstep, the applied detergent remains on the surface in order to soak into the dirt.

Second workstep (vacuuming):

After the detergent has been allowed to soak in, clean and vacuum the same surface again. To do this, open the ball cock **Fig. 234-A** again.

Press the Hako button **Fig. 234-76** and start the second workstep.

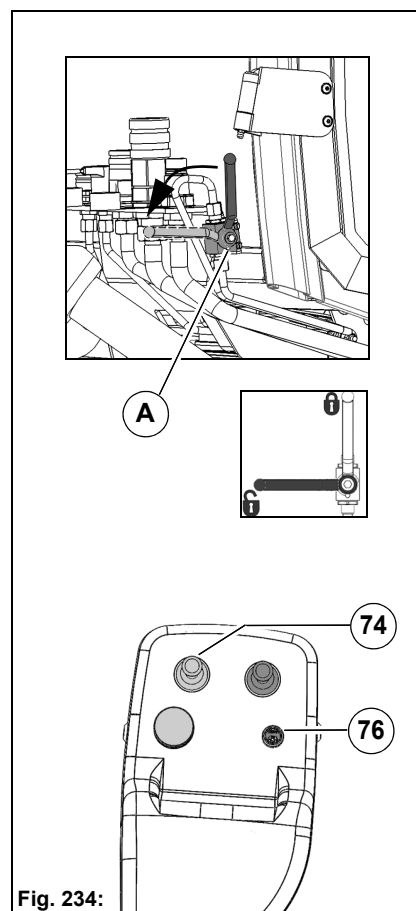


Fig. 234:

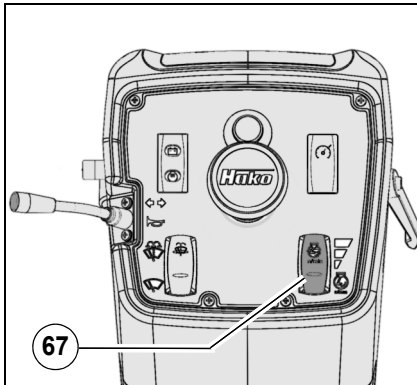


Fig. 235:

Setting the fixed engine speed

The fixed engine speed is set with the tip switch **Fig. 135-67**. Set the speed according to the requirements.

Stage	rpm	Use
1 - ECO	1600	Normal and heavy soiling

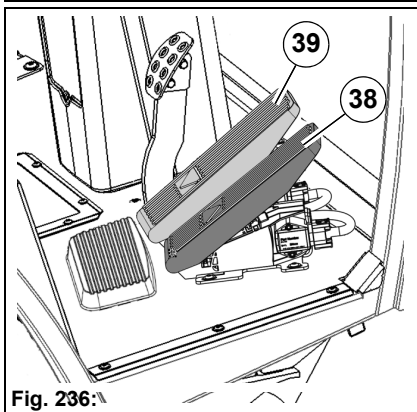


Fig. 236:

Starting wet cleaning

The accelerator pedal **Fig. 136-38** is used for continuously changing the speed for driving forwards.

The accelerator pedal **Fig. 136-39** is used for continuously changing the speed for reversing.

Push the accelerator pedal down slowly until the vehicle starts, the speed is increased further by pressing on the pedal.

Slowing down or braking the vehicle: slowly reduce the pressure on the accelerator pedal, the vehicle slows down or stops.

The maximum vehicle speed in the work mode is 16/20/27 km/h according to the selected engine speed.



Note

- For an effective and efficient cleaning result, a maximum vehicle speed of 4 km/h (depending on the degree of soiling) is recommended.
- The brush drives and the water pump are switched off when standing. This protects the floor. Move the left joystick forwards to rotate the brushes even whilst standing!
- When reversing on an uneven floor, the squeegee must be raised. Do not reverse over edges and thresholds!

Checklist – Settings for wet cleaning

No.	Description	Reference
1	Setting the water type	Page 219
2	Setting the water supply	Page 219
3	Setting the brush speed	Page 220
4	Setting the brush pressure (optional)	Page 220
5	Switching the suction fan on and off	Page 220

Setting the water type

Fresh water from the fresh water tank or circulating water from the dirt hopper can be supplied to the scrubbing deck for wet cleaning. Select the working menu in the multifunctional display with the turn-push knob **Fig. 238-73**. Change the current value in the water supply menu **Fig. 237-A**.

Select either fresh water or circulating water via the settings **Fig. 237-B** or **Fig. 237-C**.

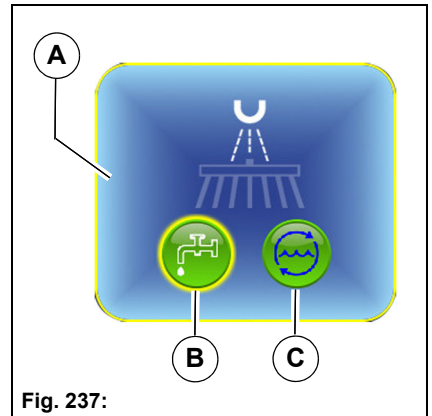


Fig. 237:

Setting the water supply

The water pump of the scrubbing deck can be switched on and off. Select the working menu in the multifunctional display with the turn-push knob **Fig. 238-73**. Change the current value in the water pump menu **Fig. 238-A**.

Setting range: On/Off or 0 to 100%

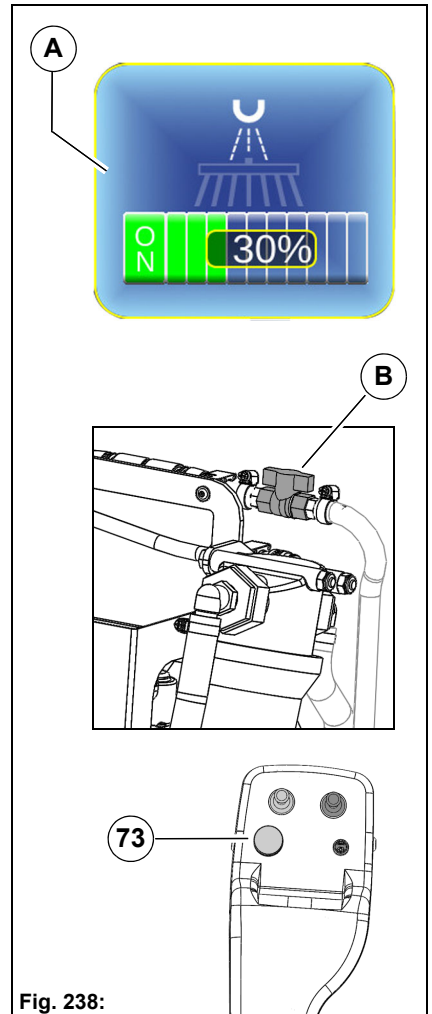



Fig. 238:

	<p>Note</p> <p>The ball cock Fig. 238-B on the scrubbing deck must be open to ensure the water pump can supply water!</p> <ul style="list-style-type: none"> • Water supply opened: butterfly handle in flow direction • Water supply shut off: butterfly handle at right angles to the flow direction
---	--

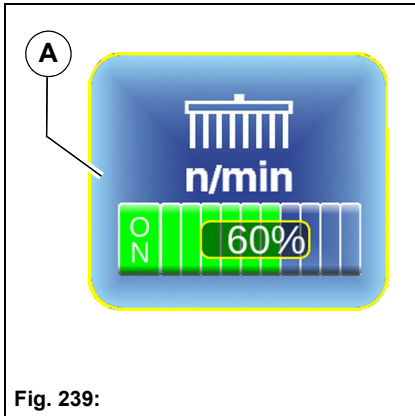


Fig. 239:

Setting the brush speed

The scrubbing result is influenced by changing the brush speed. Select the working menu in the multifunctional display with the turn-push knob **Fig. 238-73**. Change the current value in the brush speed menu **Fig. 239-A**.

Setting range: On/Off or 0 to 100%

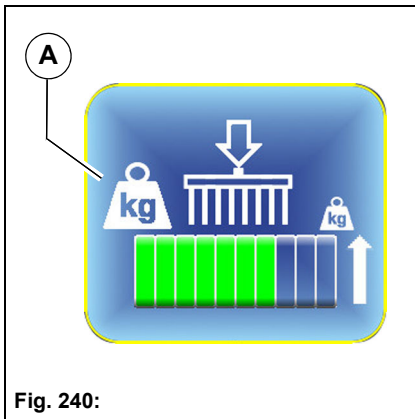


Fig. 240:

Setting the brush pressure (optional)

Using this option it is possible to reduce the brush pressure of the brushes. This is necessary for delicate surfaces or to increase the service life of the brushes.

Select the working menu in the multifunctional display with the turn-push knob **Fig. 238-73**. Change the current value in the brush pressure menu **Fig. 240-A**.

The higher the setting, the more the brushes are relieved.

Setting range: 0 to 100%

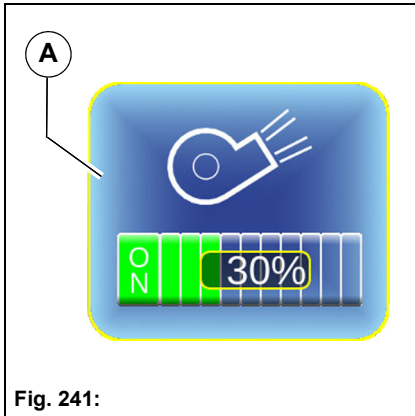


Fig. 241:

Setting the suction fan speed

The vacuuming result is influenced by changing the suction fan speed. Select the working menu in the multifunctional display with the turn-push knob **Fig. 238-73**. Change the current value in the suction fan menu **Fig. 241-A**. Noise-reduced operation is obtained in the ECO mode at suction fan output reduced to 30%.

Setting range: On/Off or 30 to 100%

Checklist – Cleaning the wet cleaning system


No.	Description	Reference
1	Emptying the dirt hopper	Page 154
2	Cleaning the dirt hopper and circulating water system	Page 156
3	Emptying the fresh water tank	Page 156
4	Emptying the circulating water tank	Page 156

6.6.4 Technical data

Vehicle with CityCleaner

Dimensions	Unit	
Length	mm	4634
Width	mm	1370
Height	mm	2215
Working width scrubbing deck	mm	1240
Working width squeegee	mm	1333
Weight	Unit	
Empty weight according to StVZO	kg	2488
Scrubbing deck	Unit	
Brush diameter	mm	460
Brush speed	rpm	140 to 200


6.6.5 Maintenance

	<p>Note Maintenance of the dirt hopper is described in the Vacuum sweeping system section.</p>
---	---

Wet cleaning system maintenance plan

Daily
<p>Squeegee</p> <ul style="list-style-type: none"> • Checking the squeegee sealing strips, turn or replace them if necessary
<p>Scrubbing deck</p> <ul style="list-style-type: none"> • Checking the lateral deflectors, turn or replace them if necessary • Checking the brushes, replace them if necessary • Checking the circulating water filter, clean it if necessary • Checking the chemical dosing system (optional)

Maintenance work

	<p>Danger</p> <ul style="list-style-type: none"> • Always bring and insert the safety strut Fig. 167-B of the dirt hopper into the upper position during maintenance and cleaning work under the raised dirt hopper. There is a risk of injury! • Staying in the danger area is forbidden when raising and lowering the dirt hopper! There is a risk of injury! <p>Warning</p> <ul style="list-style-type: none"> • Risk of crushing! The squeegee of the CityCleaner weighs more than 25 kg. Body parts may be crushed if the squeegee falls down or falls over. Always use suitable load-carrying equipment. • Risk of injury! Wear suitable protective clothing (protective gloves and safety goggles) when using detergents. • Risk of injury! There is a risk of tilting over if the squeegee is located on the trolley without the scrubbing deck. Observe the correct assembly and disassembly sequence. • Risk of injury! Always wear protective gloves when working on the lateral deflectors and brushes. <p>Attention</p> <ul style="list-style-type: none"> • At temperatures below 0 degrees (risk of frost) drain the water out from all water-conducting components.
---	--

Checking the squeegee sealing strips

Check the external squeegee sealing strips **Fig. 173-A** daily for wear.

1. Remove the scrubbing deck and the squeegee, see page 207.
2. Loosen the knurled nuts **Fig. 173-B**.
3. Remove the attachment strips **Fig. 173-C** and the external squeegee sealing strip **Fig. 173-A**.
4. Turn the squeegee sealing strip or replace it if necessary. The squeegee sealing strip can be used four times. Always use the hole pattern at the top for attachment.



Note

Observe the maximum wear limit! In order to use the squeegee strip effectively, each of the four edges must only be used up to the centre. A fully worn squeegee sealing strip, see **Fig. 173-D**, must be replaced.

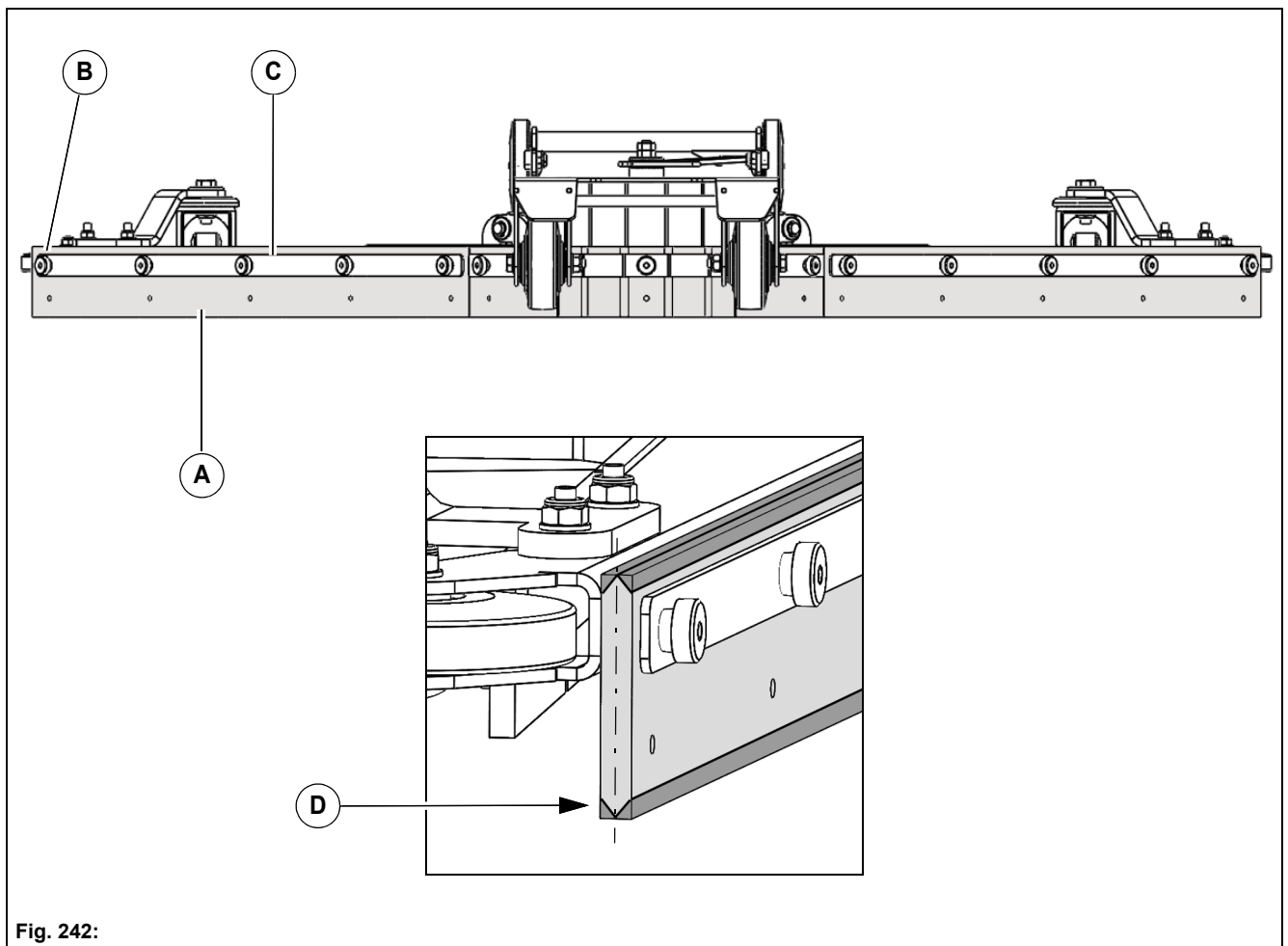


Fig. 242:

Checking the lateral deflectors



Warning

Risk of injury! Always wear protective gloves when working on the lateral deflectors.

Check the lateral deflectors **Fig. 243-A** of the scrubbing deck daily. Turn or replace worn sealing strips **Fig. 243-B**. The sealing strips **Fig. 243-B** and mounting clamps **Fig. 243-C** can be removed without tools.

1. Raise the scrubbing deck with the joystick **Fig. 243-74**.
2. The sealing strip can be removed with the mounting clamps by laterally pulling on the clamp **Fig. 243-C** of the mounting clamps.
3. Insert the new or turned sealing strip into the mounting clamps.
4. Insert the sealing strip and the mounting clamps on one side **Fig. 243-F** of the holder. The guide lugs slide into the slots **Fig. 243-G**. This ensures the correct height position.

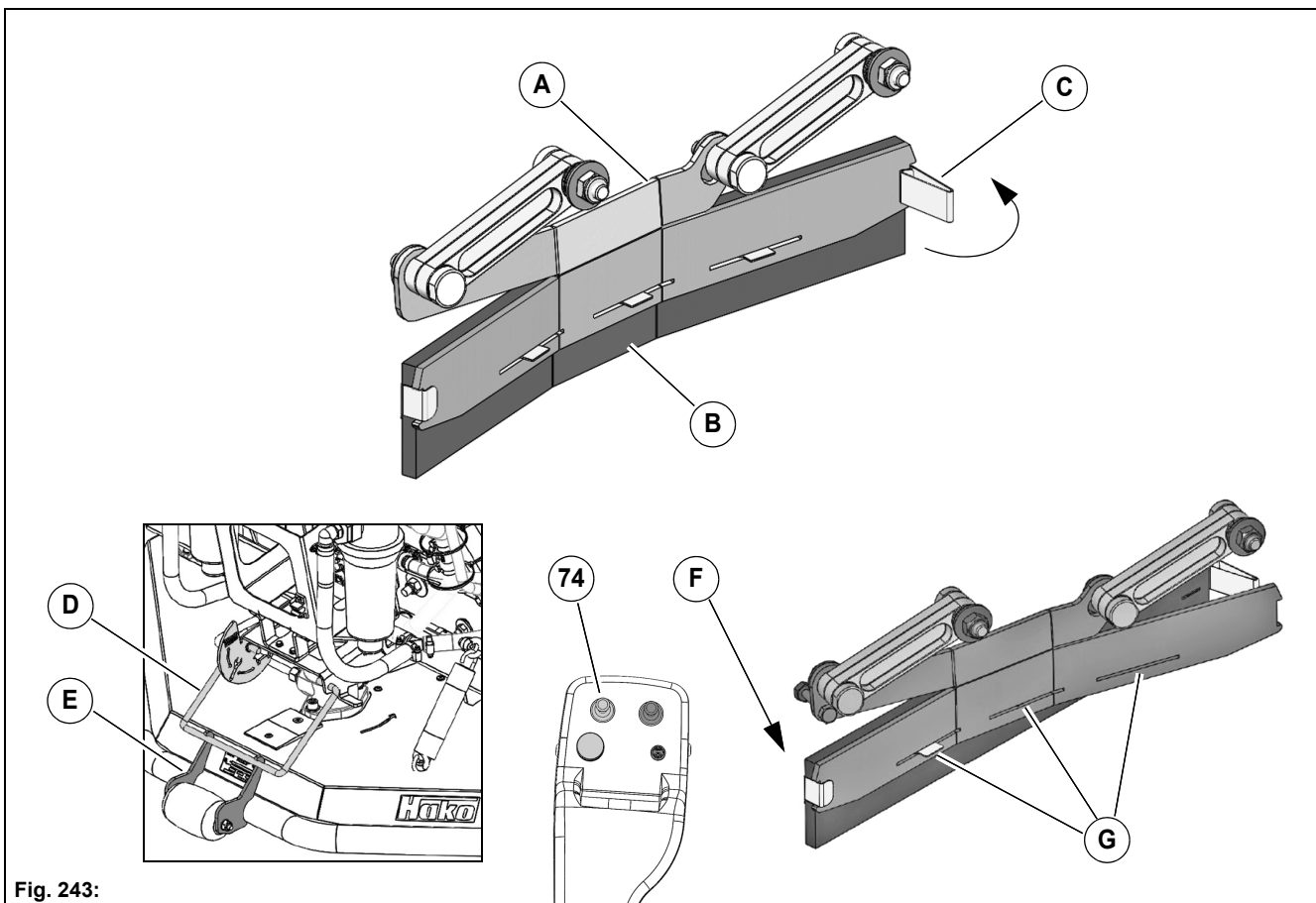



Fig. 243:

Checking the brushes

	<p>Warning</p> <ul style="list-style-type: none"> • Risk of injury! Always wear protective gloves when working on the brushes. • Risk of injury! Please be particularly careful in the area of the scrubbing deck when brushes are ejected automatically.
---	--


Check the brushes **Fig. 244-A** of the scrubbing deck daily. Replace worn brushes. The dimension **Fig. 244-X** must be at least 10 mm. The brushes can be removed without tools.

Remove brushes by hand:

1. Raise the scrubbing deck with the joystick **Fig. 244-74**.
2. Bring the locking bow **Fig. 244-B** into the service position (wrench symbol) and hook it onto the holder **Fig. 244-C**.
3. Remove the worn brushes from the carrier plates **Fig. 244-D**. To do this, remove the brush from the catch up **Fig. 244-E** by rotating it jerkily in the motor's direction of rotation (see arrow **Fig. 244-G** at the housing).
4. Mount the new brushes one after the other to the carrier plates. For this, align the carrier disks **Fig. 244-F** of the brushes to the carrier plate **Fig. 244-D** and let the brush engage at the catch up (click sound) by rotating it against the motor's direction of rotation.

Automatic brush ejection:

1. Raise the scrubbing deck with the joystick **Fig. 244-74**.
2. Pull the left joystick **Fig. 244-74** back and press the right joystick **Fig. 244-75** forward at the same time. The brushes are ejected.
3. Remove the worn brushes from the scrubbing deck.
4. Mount the new brushes one after the other to the carrier plates. For this, align the carrier disks **Fig. 244-F** of the brush to the carrier plate **Fig. 244-D**. Let the brush engage at the catch up (click sound) by rotating it against the motor's direction of rotation.

	<p>Note</p> <p>Only perform automatic brush ejection when the vehicle has stopped. The driver must be on the driver's seat for ejecting the brushes!</p>
---	---

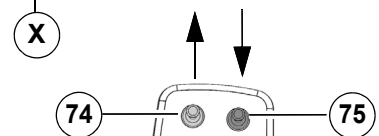
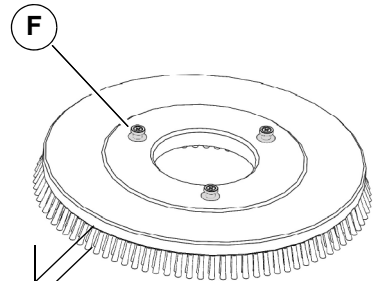
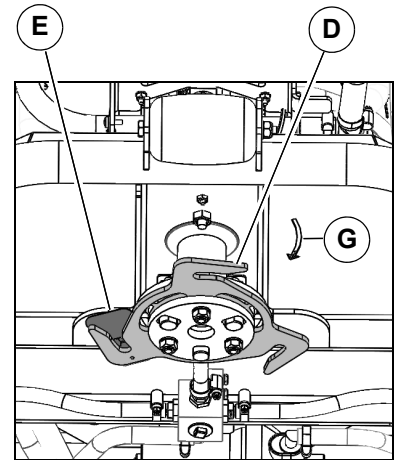
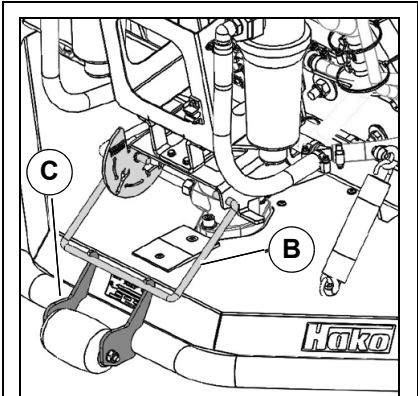
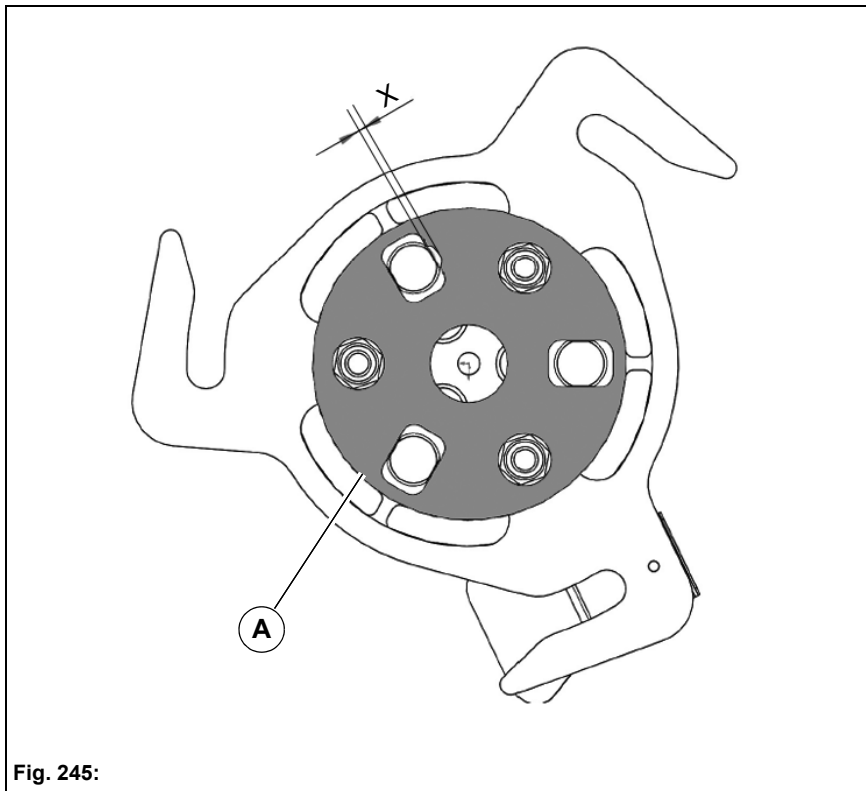


Fig. 244:

Check the locking device

Check the locking device **Fig. 245-A** at the carrier plate of the scrubbing deck every 500 operating hours. Check the locking device for wear and damage. Turn or replace it if necessary. The maximum gap **Fig. 245-X** between the bolt and the locking device should not be greater than 5 mm.



Checking the circulating water filter

Check the filter inserts of both circulating water filters **Fig. 246-A** after each use. Clean them if required.

Simple flushing:

1. Fill the dirt hopper with clean circulating water, see page 213.
2. Unscrew the locking cap **Fig. 246-B** and flush with circulating water until the water jet is clear.
3. Close the ball cock **Fig. 246-10** and re-attach the locking caps.
4. Open the ball cock **Fig. 246-10** again.

Thorough cleaning:

1. Shut off the ball cock **Fig. 246-10**.
2. Unscrew the circulating water filter **Fig. 246-A**.
3. Remove the filter insert and clean it thoroughly using a water hose.
4. Re-attach the circulating water filter.
5. Open the ball cock **Fig. 246-10** again!

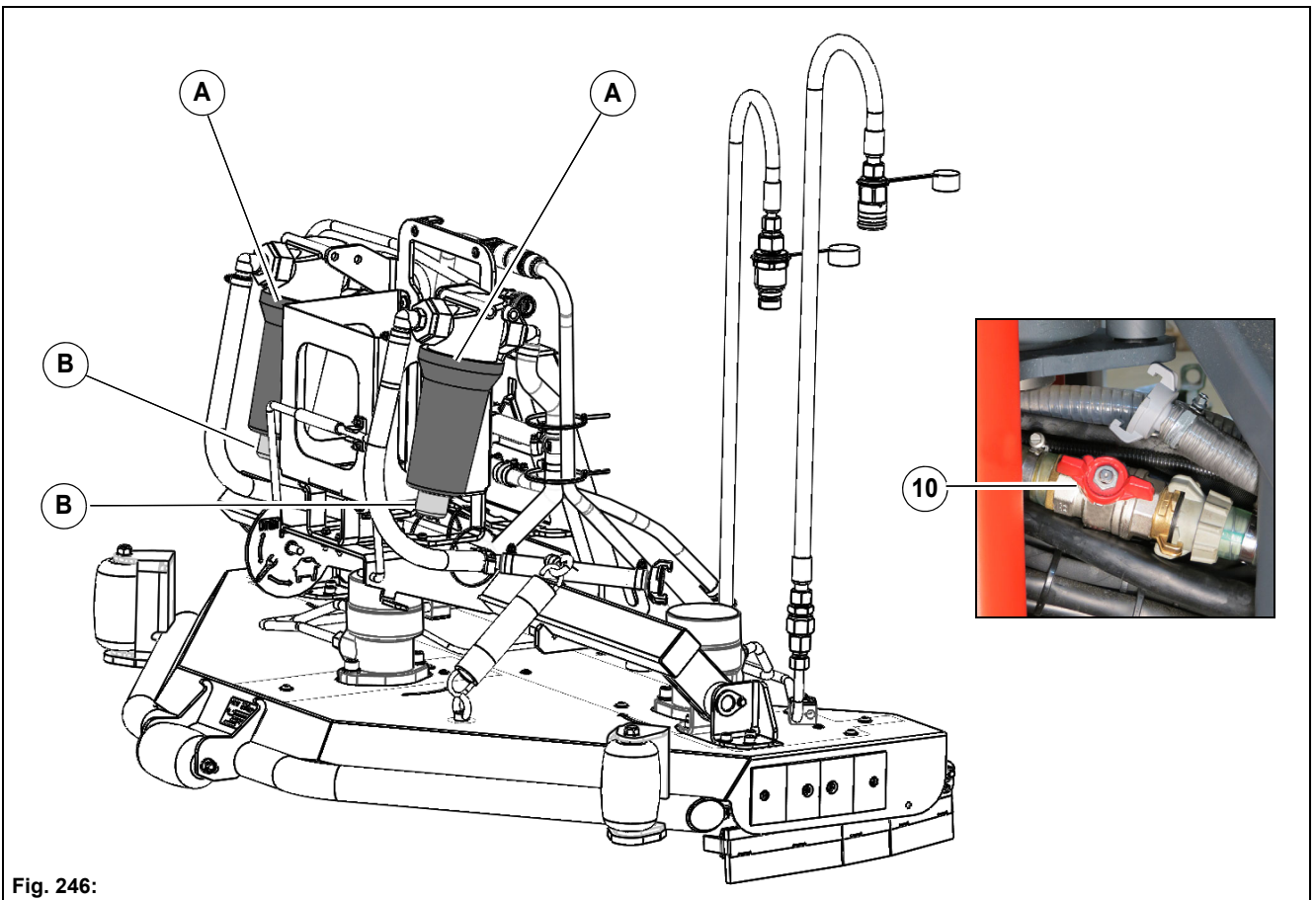


Fig. 246:

6.6.6 Troubleshooting

No water at the brushes	Remedy
	Open the ball cock in the articulation area or on the scrubbing deck
	Fill the fresh water tank
	Fill the dirt hopper
	Switch on the water pump
	Switch on the water supply
	Clean the circulating water filter
	Check for frost damage
Foam formation	Remedy
	Set the chemical dosing system
The dirt hopper loses water	Remedy
	Level in the dirt hopper too high
	Fill less circulating water into the dirt hopper when it is raining or wet
	Start or brake movement too strong
Bad vacuuming result	Remedy
	Increase the suction fan speed
	Empty the dirt hopper
	Check the supporting wheels at the squeegee
	Check the sealing strips at the wiper and at the squeegee
	Check whether the squeegee is positioned correctly
Noise emission at the scrubbing deck	Remedy
	Change the speed of the brushes
	Check the locking device

6.6.7 Accessories

Your authorised Hako dealer is available to you at any time to answer questions on accessories for the CityCleaner.

**Hako GmbH
Hamburger Str. 209-239
23843 Bad Oldesloe, Germany**

declare in sole responsibility that the following products

**Dirt hopper – Citymaster 1650 / type: 1488
Sweeping unit – Citymaster 1650 / type: 1489
Front mower – Citymaster 1650 / type: 8131
Front sweeping machine – Citymaster 1650 / type: 589530
Loading platform – Citymaster 1650 / type: 143830
CityCleaner – Citymaster 1650 / type: 615400**

on which this declaration is based correspond with the relevant basic safety and health requirements of the EC Directive 2006/42/EC as well as the requirements according to 2014/30/EC.

The following standard(s) and technical specifications was/were referred to for the correct implementation of the safety and health requirements named in the EC Directive:

**EN 13019 for dirt hopper – Citymaster 1650 / type: 1488
EN 13019 for sweeping unit – Citymaster 1650 / type: 1489
EN 836 for front mower – Citymaster 1650 / type: 8131
EN 13524 for front sweeping machine – Citymaster 1650 / type: 589530
EN 12100 for loading platform – Citymaster 1650 / type: 143830
EN 13019 for CityCleaner – Citymaster 1650 / type: 615400**

Name of the authorised person who compiles the technical documents for Hako:

Ludger Lüttel

Bad Oldesloe, 23.01.2018



Axel Jensen
Product line manager
Municipal technology



Hako GmbH
Head Office
Hamburger Str. 209-239
23843 Bad Oldesloe
Germany
Tel. +49 4531 806-0
info@hako.com
www.hako.com